

Hydraulic cylinders

RE 17017/08.08
Replaces: 05.03

1/72

Series CD210 / CG210

Component series 1X
Nominal pressure 210 bar (21 MPa)

K4639-5

Table of contents

Content	Page	Content	Page
Features, technical data	2	Piston Ø 125	38 to 43
General notes, engineering software ICS	2	Piston Ø 150	44 to 49
Forces, areas	3	Piston Ø 180	50 to 55
Mounting types	4	Piston Ø 200	56 to 61
Ordering code	5	Weight	62
Position of line ports	6	Permissible stroke lengths	63 to 65
Explanations	7	Calculation of buckling, stop tube extension	66
Cylinder data		installation lengths and position tolerances	67
Piston Ø 40	8 to 13	Inductive proximity switch	68
Piston Ø 50	14 to 19	Proximity switch, technical data	69
Piston Ø 63	20 to 25	Seals, end position cushioning	70
Piston Ø 80	26 to 31	Calculation of braking force	71
Piston Ø 100	32 to 37	Spare parts drawing	72

Information on available spare parts:
www.boschrexroth.com/spcEngineering software **Interactive Catalog System**Online www.boschrexroth.com/ics**Brochure download** www.boschrexroth.com/business_units/bri/de/downloads/ihc

Features

- Service-friendly modular construction kit system, mounting of head and cap according to the tie rod principle
- Operating pressure up to max. 210 bar
- 16 mounting types
- Piston Ø: 40 to 200 mm
- Piston rod Ø: 16 to 140 mm

Note!

For the selection of the cylinder variant, please observe the Explanations on page 6!

Technical data (for applications outside these parameters, please consult us!)

Nominal pressure: 210 bar [21 MPa]

Static test pressure: Permissible operating pressure x 1.3 (depending on piston Ø and type of mounting)

Maximum operating pressure: 210 bar [21 MPa] (depending on piston Ø and type of mounting)

The given operating pressures are valid for applications with jerk-free operation.

In the case of extreme loads, e.g. rapid cycle sequence, mounting elements and threaded piston rod connections must be rated for durability.

Installation position: Optional

Hydraulic fluid:

Mineral oils DIN 51524 (HL, HLP)
Phosphate ester (HFD-R)

Hydraulic fluid temperature range: –20 °C to +80 °C

Ambient temperature range: –20 °C to +80 °C

Optimum viscosity range: 20 to 100 mm²/s

Min. viscosity: 12 mm²/s

Max. viscosity: 380 mm²/s

Cleanliness class to ISO

Permissible maximum degree of contamination of the hydraulic fluid to ISO 4406 (c) Class 20/18/15.

The cleanliness classes specified for components must be adhered to in hydraulic systems. Effective filtration prevents

malfunction and, at the same time, prolongs the service life of components.

For the selection of filters, see data sheets RE 50070, RE 50076, RE 50081, RE 50086, RE 50087, RE 50088.

Stroke velocity: Up to 0.5 m/s (depending on line connection)

Bleed points standard

Tolerances:

For stroke tolerances, permissible installation lengths and position tolerances, see page 67.

Primer coating:

As a standard, hydraulic cylinders are primed with one coating (color: gentian blue, RAL 5010) in a thickness of max. 80 µm.

The following surfaces on cylinders and attached parts are not primed or paint-coated:

- All diameters of fit to the customer side
- Sealing faces for the line connection
- Sealing faces for flanged connections
- Inductive proximity switches

Surfaces that are not paint-coated are protected by an anti-corrosion agent (MULTICOR LF 80).

Acceptance:

Each cylinder is tested according to Bosch Rexroth standard.

General notes

Safety notes:

For the installation, commissioning and maintenance of hydraulic cylinders, observe operating instructions RE 07100-B!

Servicing and repair work must be carried out by Bosch Rexroth AG or personnel having undergone special training in this field. No warranty is granted for damage resulting from installation, maintenance or repair work not carried out by Bosch Rexroth AG.

Checklists for hydraulic cylinders:

Cylinders, the operating data of which differ from the specified values, can only be offered as special variants on request.

For the preparation of offers, the deviations of technical data and/or operating data must be described in the checklists for hydraulic cylinders (RE 07200).

Engineering software ICS (Interactive Catalog System)

The ICS (Interactive Catalog System) is a selection and engineering aid for hydraulic cylinders. With the help of the ICS, designers of plant and machinery can quickly and reliably find the optimum hydraulic cylinder solution through logic-guided type code queries. This software helps to solve design and engineering tasks more quickly and efficiently. After having

been guided through the product selection, the user quickly and reliably gets the exact technical data of the selected components as well as 2D and 3D CAD data in the correct file format for all common CAD systems.

This allows users to reduce costs while increasing their competitiveness.

Forces and areas

Operating pressure in bar	Piston Ø	mm	40			50			63			
	Piston rod Ø	mm	16	18	25	22	25	36	25	28	36	45
75	Force; piston side	kN	9.43			14.73			23.38			
	Force; piston rod side	kN	7.91	7.51	5.37	11.88	11.04	7.10	19.69	18.76	15.74	11.44
100	Force; piston side	kN	12.56			19.64			31.18			
	Force; piston rod side	kN	10.56	10.03	7.66	15.84	14.71	9.47	26.26	25.03	20.99	15.26
150	Force; piston side	kN	18.85			29.45			46.76			
	Force; piston rod side	kN	15.84	15.04	11.48	23.76	22.08	14.20	39.40	37.53	31.49	22.90
210	Force; piston side	kN	26.39			41.24			65.46			
	Force; piston rod side	kN	22.17	21.05	16.05	33.27	30.91	19.88	55.15	52.55	44.08	32.06
Piston area		cm ²	12.56			19.63			31.16			
Annulus area		cm ²	10.55	10.02	7.65	15.83	14.71	9.46	26.25	25.01	20.98	15.26
Area ratio		φ	1.2:1	1.25:1	1.6:1	1.25:1	1.35:1	2:1	1.2:1	1.25:1	1.4:1	2:1
Cushioning area	Piston side	cm ²	6.84			13.91			22.10			
	Piston rod side	cm ²	8.76	8.76	6.41	14.33	13.47	8.29	23.10	23.10	19.80	13.10

Operating pressure in bar	Piston Ø	mm	80			100			125			
	Piston rod Ø	mm	36	45	56	45	50	70	50	56	63	90
75	Force; piston side	kN	37.70			58.91			92.04			
	Force; piston rod side	kN	30.07	25.77	19.22	46.97	44.18	30.05	77.31	73.57	68.66	44.33
100	Force; piston side	kN	50.27			78.54			122.72			
	Force; piston rod side	kN	40.10	34.36	25.63	62.63	58.91	40.06	103.08	98.10	91.55	59.11
150	Force; piston side	kN	75.40			117.81			184.08			
	Force; piston rod side	kN	60.14	51.54	38.45	93.95	88.37	60.10	154.63	147.13	137.32	88.66
210	Force; piston side	kN	210.56			164.94			257.71			
	Force; piston rod side	kN	84.20	72.15	53.83	131.53	123.71	84.13	216.48	206.00	192.25	124.13
Piston area		cm ²	50.24			78.50			122.66			
Annulus area		cm ²	40.07	34.34	25.62	62.60	58.88	40.04	103.03	98.04	91.50	59.08
Area ratio		φ	1.25:1	1.4:1	2:1	1.25:1	1.35:1	2:1	1.2:1	1.25:1	1.35:1	2:1
Cushioning area	Piston side	cm ²	30.63			58.90			92.50			
	Piston rod side	cm ²	36.40	30.60	20.10	57.30	54.70	31.97	92.50	92.50	47.20	47.20

Operating pressure in bar	Piston Ø	mm	150				180			200		
	Piston rod Ø	mm	63	70	80	100	80	90	125	90	100	140
75	Force; piston side	kN	132.54				190.85			235.62		
	Force; piston rod side	kN	109.16	103.68	94.84	73.63	153.16	143.14	98.81	187.92	176.72	120.17
100	Force; piston side	kN	176.72				254.47			314.16		
	Force; piston rod side	kN	145.55	138.24	126.45	98.18	204.21	190.85	131.75	250.56	235.63	160.23
150	Force; piston side	kN	265.08				381.70			471.24		
	Force; piston rod side	kN	218.33	207.38	189.68	147.28	306.32	286.28	197.63	375.85	353.45	240.34
210	Force; piston side	kN	371.10				534.39			659.74		
	Force; piston rod side	kN	305.65	290.32	265.55	206.20	428.85	400.80	276.70	526.18	494.83	336.50
Piston area		cm ²	176.63				254.34			314.00		
Annulus area		cm ²	145.47	138.17	126.38	98.13	204.10	190.75	131.68	250.42	235.50	160.14
Area ratio		φ	1.2:1	1.25:1	1.4:1	1.8:1	1.25:1	1.35:1	2:1	1.25:1	1.35:1	2:1
Cushioning area	Piston side	cm ²	126.50				193.6			235.60		
	Piston rod side	cm ²	130.10	130.10	81.70	81.70	179.00	179.00	109.20	238.70	219.00	137.50

Mounting types

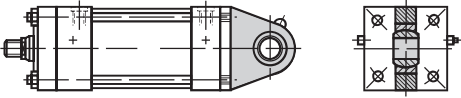
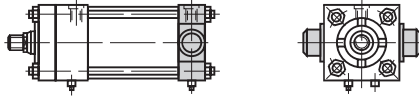
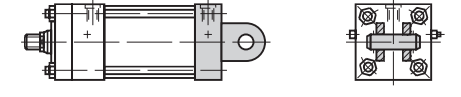
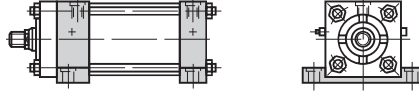
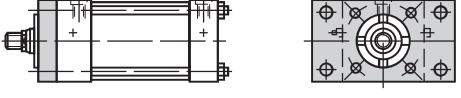
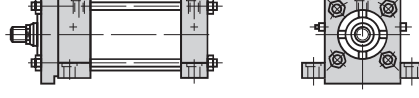
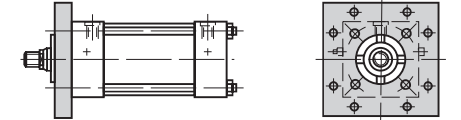
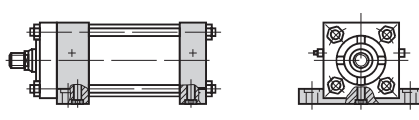
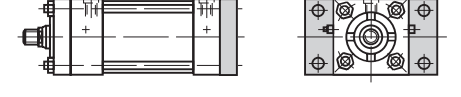
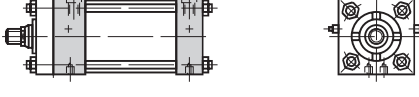
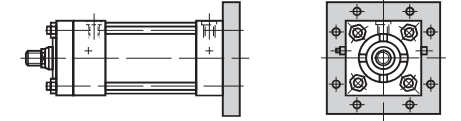
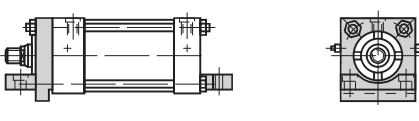
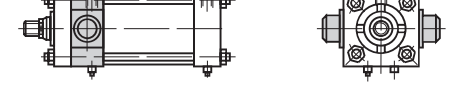
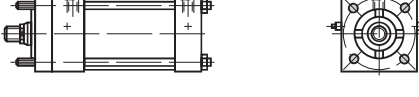
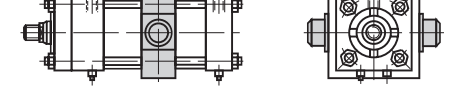
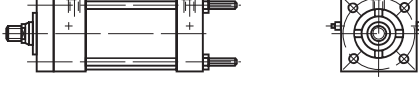
<p>Self-aligning clevis at cylinder cap</p> <p>B</p>		<p>Trunnion at cylinder cap</p> <p>S</p>	
<p>Fork clevis at cylinder cap</p> <p>G</p>		<p>Foot mounting</p> <p>F</p>	
<p>Rectangular flange at cylinder head</p> <p>C</p>		<p>Foot mounting with splined key</p> <p>L</p>	
<p>Square flange at cylinder head</p> <p>H</p>		<p>Foot mounting with seal ring for subplate mounting</p> <p>M</p>	
<p>Rectangular flange at cylinder cap</p> <p>D</p>		<p>Threaded bores in cylinder head and cap</p> <p>N</p>	
<p>Square flange at cylinder cap</p> <p>K</p>		<p>Foot mounting at front face with splined key</p> <p>T</p>	
<p>Trunnion at cylinder head</p> <p>R</p>		<p>Extended tie rods at cylinder cap</p> <p>P</p>	
<p>Trunnion at the center of the cylinder</p> <p>E</p>		<p>Trunnion at the center of the cylinder</p> <p>Q</p>	

Position of line ports

By turning the cylinder head and/or cylinder cap the position of pipe ports can be varied for most of the cylinder mounting types during installation. The options can be seen in the table below.

The throttle and check valves change their position accordingly.

In the case of mounting types F, L, N and T, as well as on the cylinder cap for type of mounting G, the throttle and check valves are located at position 1 when the pipe connection is rotated.

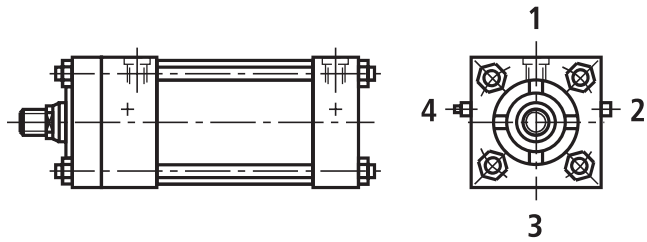

Mounting types	Selectable position of line ports															
	B	C	D	E	F	G	H	K	L	M	N	P	Q	R	S	T
At cylinder head	1	1	1	1	1	1	1	1	1	-	1	1	1	1	1	1
	2	2	2	2	□ 2	2	2	2	□ 2	-	■ 2	2	2	-	2	2
	3	3	3	3	-	3	3	3	-	3	-	3	3	3	3	-
	4	4	4	4	□ 4	4	4	4	□ 4	-	■ 4	4	4	4	-	4
At cylinder cap	1	1	1	1	1	1	1	1	1	-	1	1	1	1	1	1
	2	2	■ 2	2	□ 2	2	2	2	□ 2	-	■ 2	2	2	2	-	2
	3	3	3	3	-	3	3	3	-	3	-	3	3	3	3	-
	4	4	■ 4	4	□ 4	4	4	4	□ 4	-	■ 4	4	4	4	4	-

■ = Position 2 and 4 not possible for:
Piston Ø 40 with enlarged pipe connection 13 and 14

□ = Position 2 and 4 not possible for piston Ø 40; 50 and 63

Explanations (explanation of items on pages 8 to 61)

- 1 Selectable position of line ports (see page 6).
- 12 Check valve and bleed point.
The bleed point is provided as standard.
- 13 Adjustable throttle valve for end position cushioning.
- 14 Thread versions B and C. Thread versions E and F as well as the associated self-aligning clevis are given on the last page of each piston Ø.
- 15 Observe the permissible loading for the screwed-on self-aligning clevis.
- 16 Associated pin Ø with fit m6.
Minimum strength of pin material $\sigma_{0.2} = 600 \text{ N/mm}^2$
(is not included in the scope of supply).
- 17 Pins and split pins are included in the scope of supply.
- 20 Grease nipple, cone head form A to DIN 71412. As lubrication greases, commercial, anti-corrosion greases on lithium soap base can be used.
- 21 Lubrication possible via lubrication bore in the housing.
- 22 In conjunction with line connection 13 and 14, counter-sink Ø D1 on cap side is not suitable for seal ring fittings.
- 23 On the version with enlarged line connection 13 and 14 the distance between the two ports changes.
- 24 Double-rod cylinder CG,
max. tensile loading 13 kN on side "Y"

Piston Ø 40 (dimensions in mm)

For explanations of items, see page 7

Type of mounting B Operating pressure 210 bar

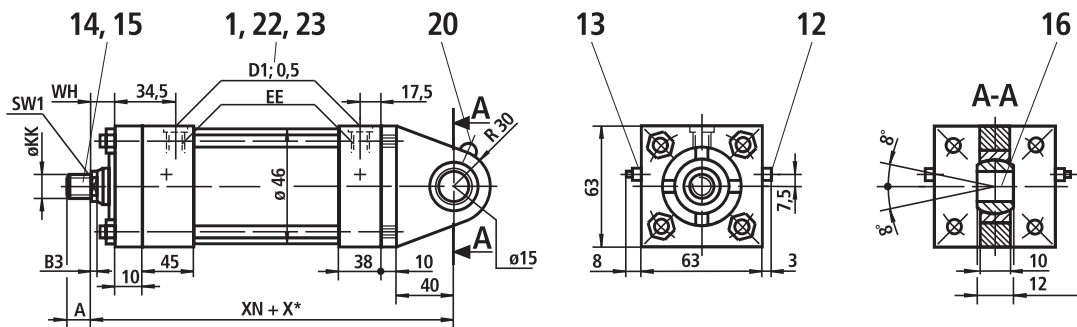

Type of mounting G Operating pressure 210 bar

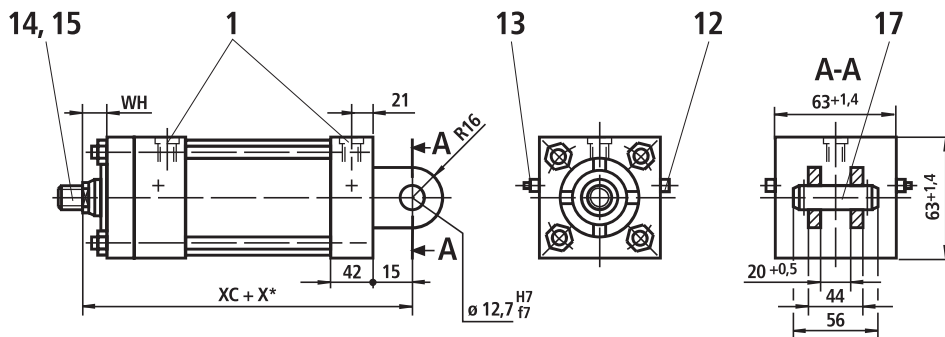

Type of mounting C Operating pressure with piston rod Ø 16 and 18: 180 bar on cap side; 210 bar on piston rod side
 Operating pressure with piston rod Ø 25: 110 bar on cap side; 210 bar on piston rod side

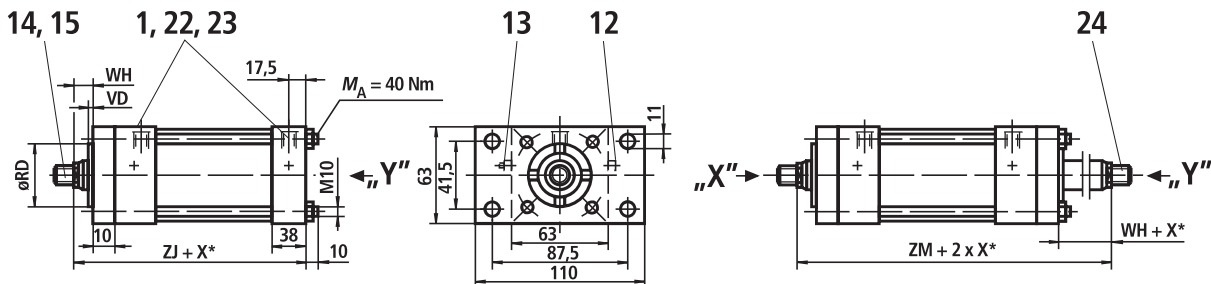

Stroke_{min} = 25 mm with thread version "E"
 (only for double-rod cylinder)

Piston rod Ø	KK			A		EE				D1			
	Thread version			Thread version		Pipe connection				Pipe connection			
	C, E	B	F	C, E, B	F	01	13	02	14	01	13	02	14
16	M10 x 1.5	M12 x 1.5	M14	19	35	G1/2	G3/4	M22 x 1.5	M27 x 2	34	42	34	42
18	M10 x 1.5	M12 x 1.5	M14	19	35								
25	M20 x 1.5	M22 x 1.5	M20 x 1.5	28	45								

X* = stroke length ▽ max. tensile load 13 kN

Piston Ø 40 (dimensions in mm)

For explanations of items, see page 7

Type of mounting H Operating pressure 210 bar

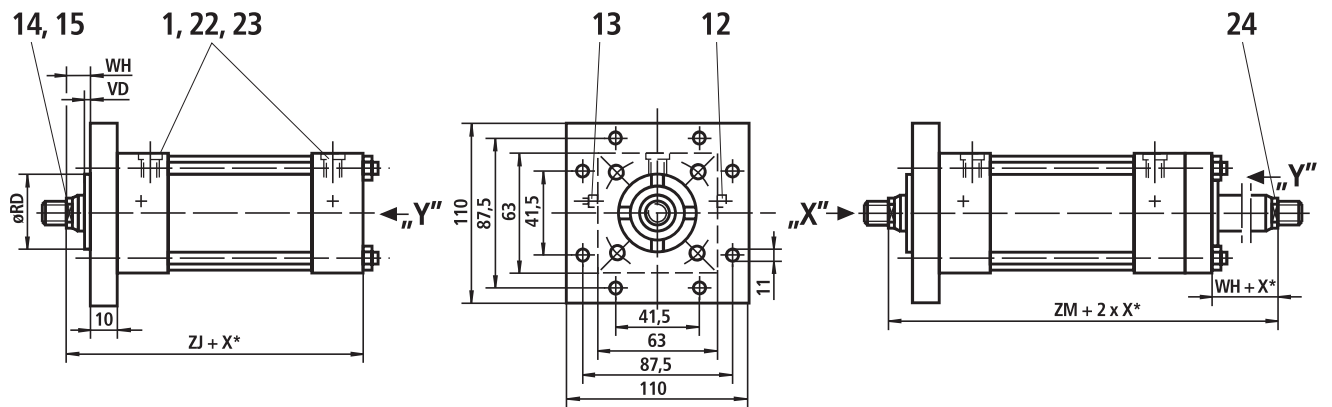

Stroke_{min} = 25 mm with thread version "E"
(only for double-rod cylinder)

Type of mounting D Operating pressure 210 bar

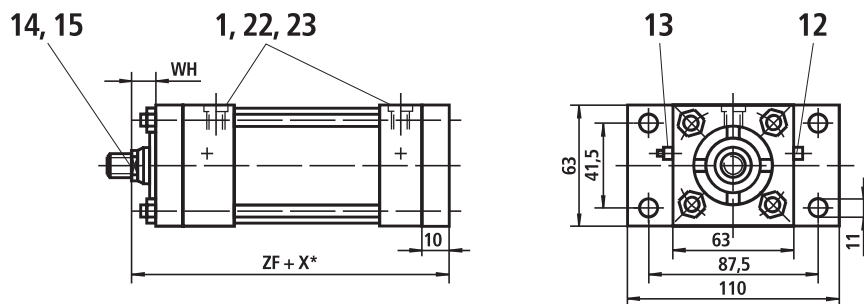

Type of mounting K Operating pressure 210 bar

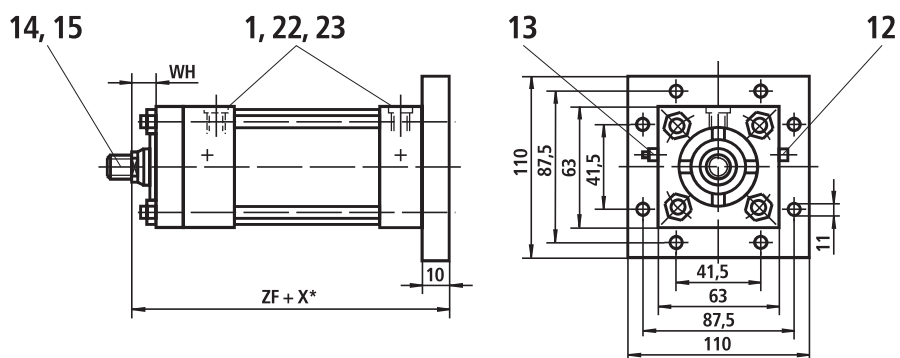

Piston rod Ø	ØRD f7	VD	WH	XC	XN	ZF	ZJ	ZM	B3	SW1	Cushioning lengths	
											piston side	piston rod side
16	28.5	6	16	162	193	153	143	176	5	13	30	30
18	32	6	16	162	193	153	143	176	5	14		
25	38	13	25	171	202	162	152	194	7	22		

X* = stroke length

Piston Ø 40 (dimensions in mm)

For explanations of items, see page 7

Type of mounting R Operating pressure 210 bar

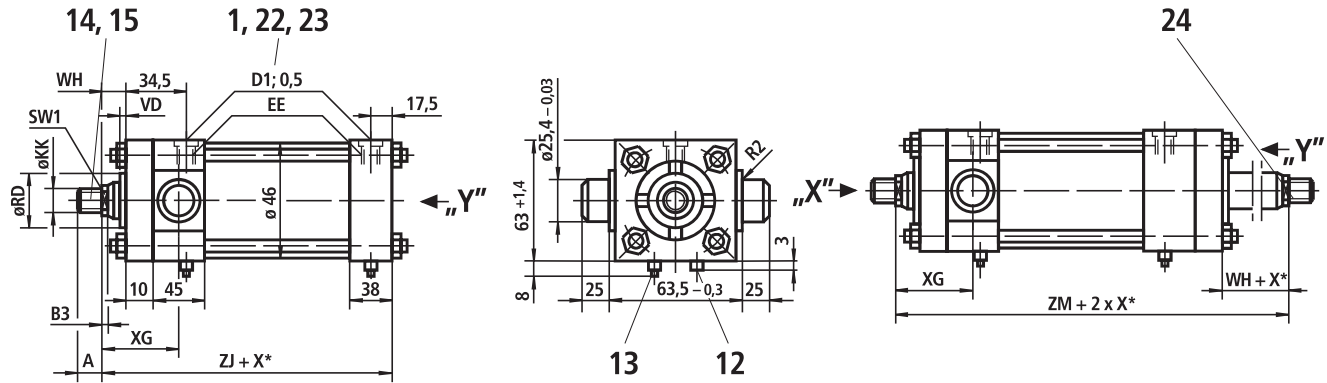

Stroke_{min} = 25 mm with thread version "E"
(only for double-rod cylinder)

Type of mounting E Operating pressure 210 bar

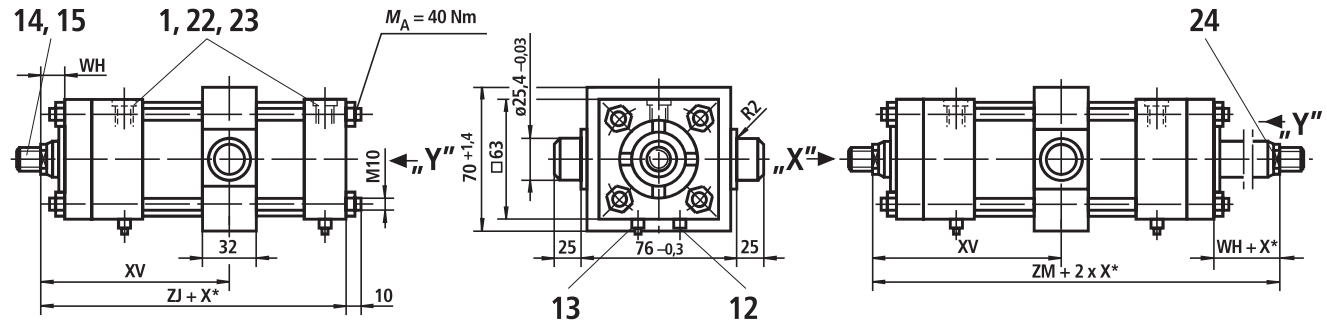

Stroke_{min} = 10 mm
Always specify dimension "XV"
in clear text on the order
(observe XV_{min} and XV_{max})

Note:
Dimensions for cylinder with piston rod
extension "LY" in the retracted
condition, see index 2 on page 5.

Stroke_{min} = 25 mm
with thread version "E"
(only for double-rod cylinder)

Type of mounting S Operating pressure 210 bar

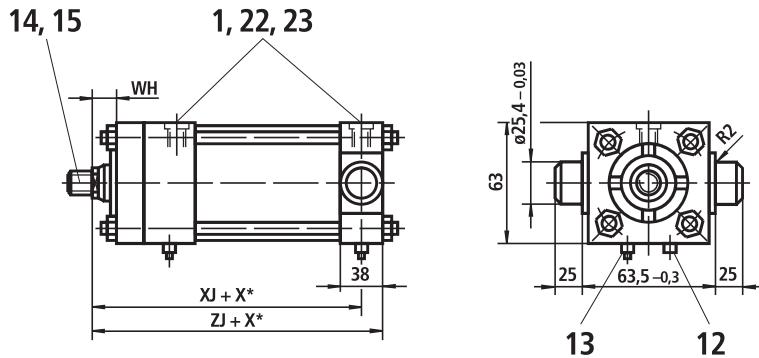

Piston rod Ø	KK			A		EE				D1			
	Thread version			Thread version		Pipe connection				Pipe connection			
	C, E	B	F	C, E, B	F	01	13	02	14	01	13	02	14
16	M10 x 1.5	M12 x 1.5	M14	19	35	G1/2	G3/4	M22 x 1.5	M27 x 2	34	42	34	42
18	M10 x 1.5	M12 x 1.5	M14	19	35								
25	M20 x 1.5	M22 x 1.5	M20 x 1.5	28	45								

X* = stroke length ▽ max. tensile load 13 kN

Piston Ø 40 (dimensions in mm)

For explanations of items, see page 7

Type of mounting Q Operating pressure 210 bar

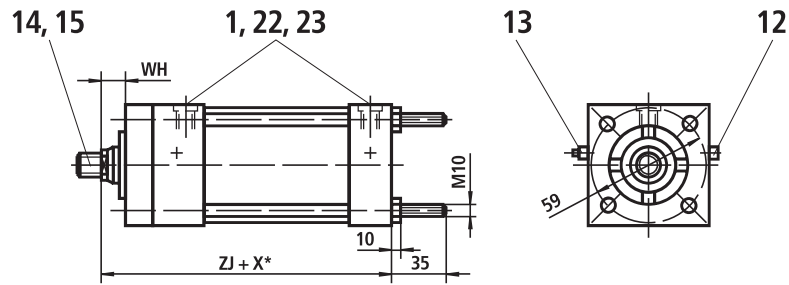

Additional thread versions

Thread version "E"

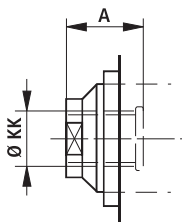

Thread version "F"

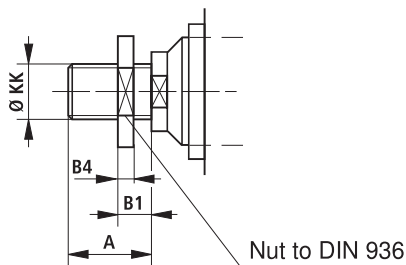

Self-aligning clevis CGK 15

suitable for thread version "F"
 Material no.: **R900001328**
 Weight: 0.16 kg
 Permissible load: 18 kN

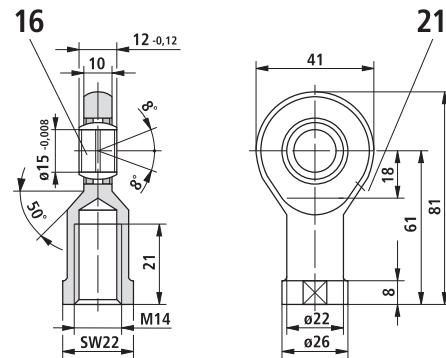

Self-aligning clevis CGK 20

suitable for thread version "F"
 Material no.: **R900001329**
 Weight: 0.34 kg
 Permissible load: 30 kN

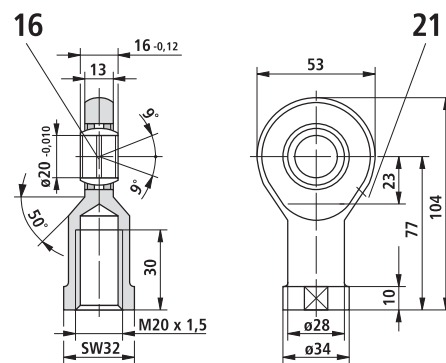

Piston rod Ø	ØRD f7	B4	VD	WH	ZJ	ZM	B1	B2	B3	SW1	Cushioning lengths	
											piston side	piston rod side
16	28.5	8	6	16	143	176	14	12	5	13	30	30
18	32	8	6	16	143	176	14	12	5	14		
25	38	9	13	25	152	194	15	12	7	22		

X* = stroke length

Piston Ø 50 (dimensions in mm)

For explanations of items, see page 7

Type of mounting B Operating pressure 210 bar

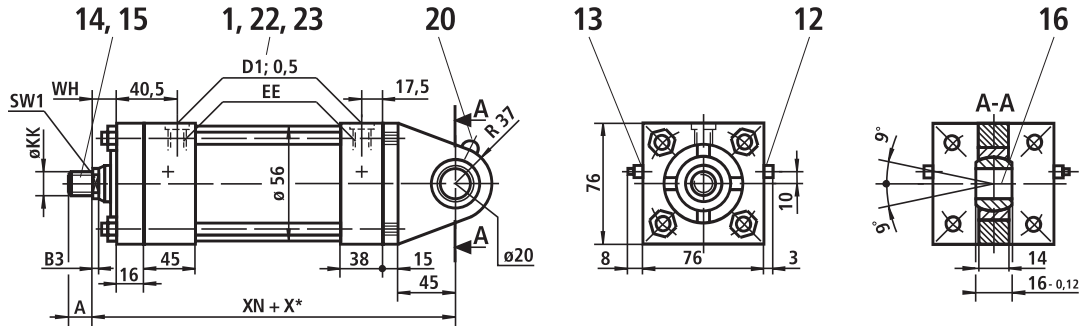

Type of mounting G Operating pressure 210 bar

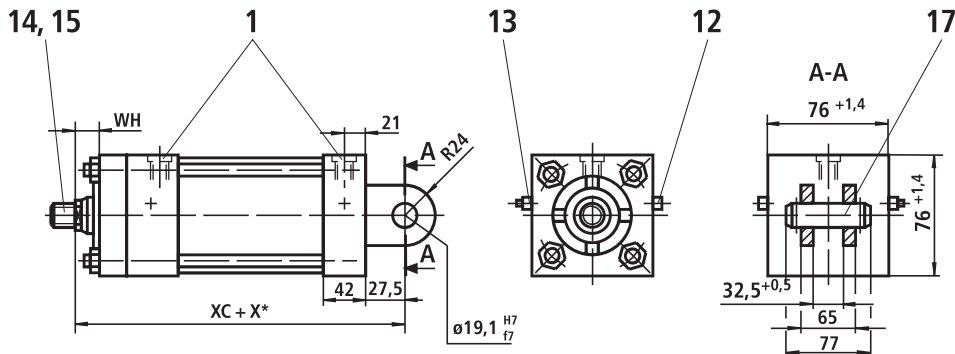

Type of mounting C Operating pressure with piston rod Ø 22 and Ø 25: 180 bar on cap side, 210 bar on piston rod side
 Operating pressure with piston rod Ø 36: 110 bar on cap side, 210 bar on piston rod side

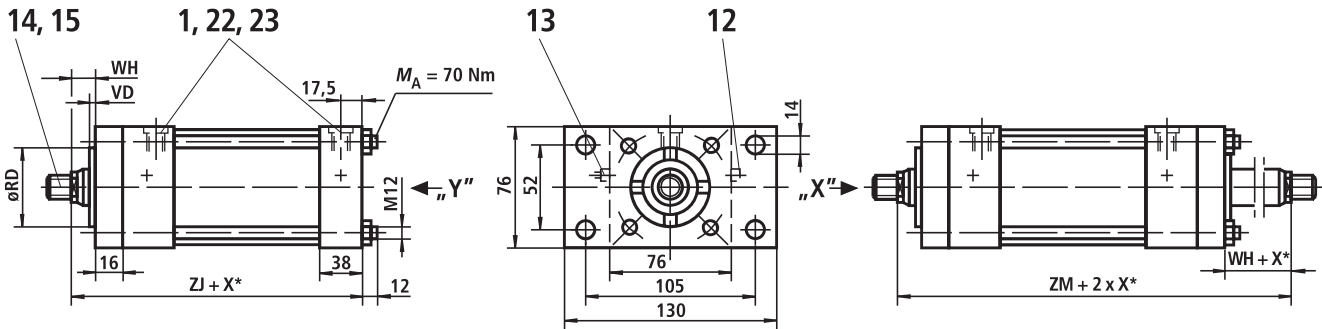

Stroke_{min} = 30 mm with thread version "E"
 (only for double-rod cylinder)

Piston rod Ø	KK			A		EE				D1			
	Thread version			Thread version		Pipe connection				Pipe connection			
	C, E	B	F	C, E, B	F	01	13	02	14	01	13	02	14
22	M16 x 1.5	M20 x 1.5	M20 x 1.5	28	45	G1/2	G3/4	M22 x 1.5	M27 x 2	34	42	34	42
25	M20 x 1.5	M22 x 1.5	M20 x 1.5	28	45								
36	M26 x 1.5	M30 x 2	M24 x 2	41	55								

X* = stroke length

Piston Ø 50 (dimensions in mm)

For explanations of items, see page 7

Type of mounting H Operating pressure 210 bar

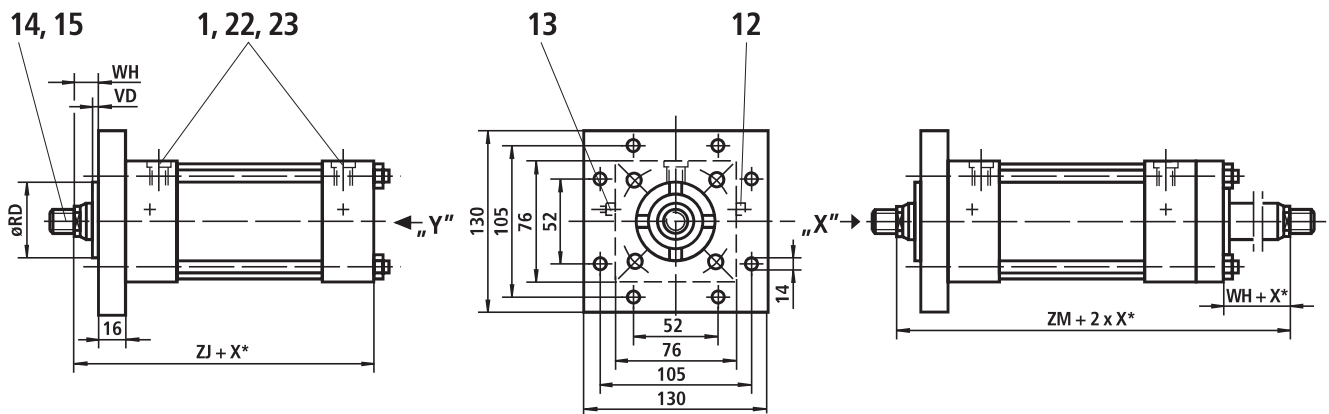

Stroke_{min} = 30 mm with thread version "E"
(only for double-rod cylinder)

Type of mounting D Operating pressure 210 bar

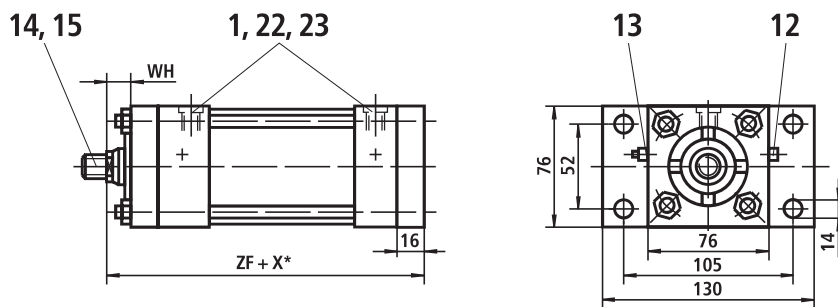

Type of mounting K Operating pressure 210 bar

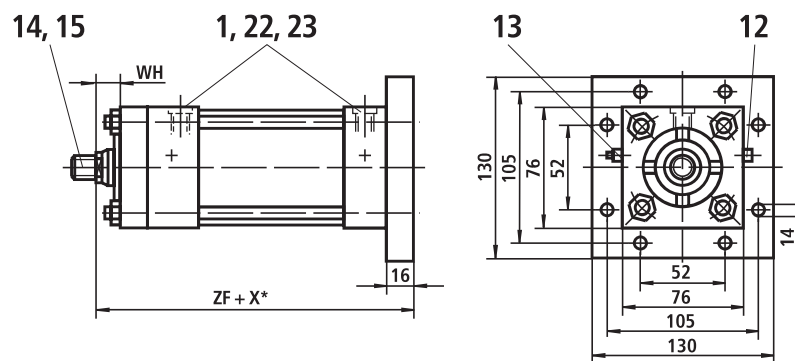

Piston rod Ø	ØRD f7	VD	WH	XC	XN	ZF	ZJ	ZM	B3	SW1	Cushioning lengths	
											piston side	piston rod side
22	38	6	19	184	212.5	168.5	152.5	194.5	8	19	30	30
25	38	7	19	184	212.5	168.5	152.5	194.5	8	22		
36	50	10	25.5	190.5	219	175	159	207.5	8	30		

X* = stroke length

Piston Ø 50 (dimensions in mm)

For explanations of items, see page 7

Type of mounting R Operating pressure 210 bar

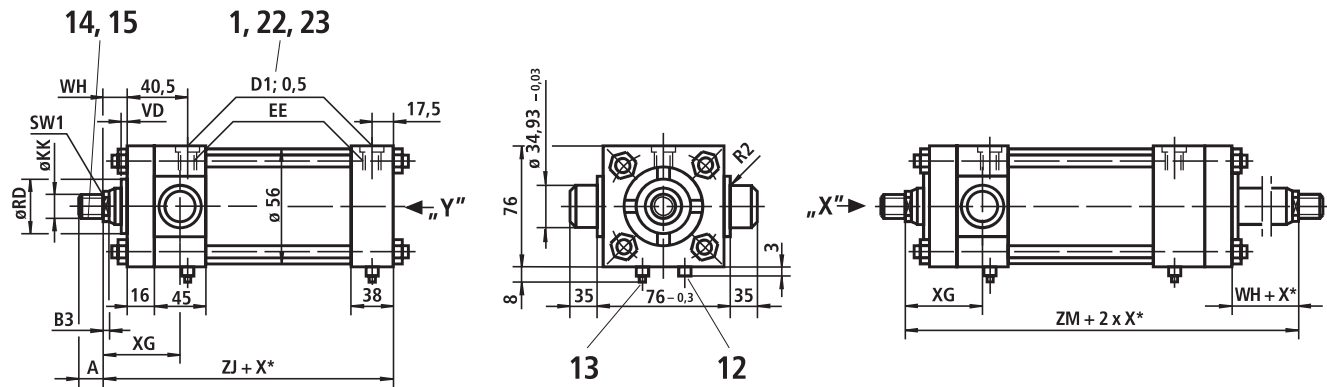

Stroke_{min} = 30 mm with thread version "E"
(only for double-rod cylinder)

Type of mounting E Operating pressure 210 bar

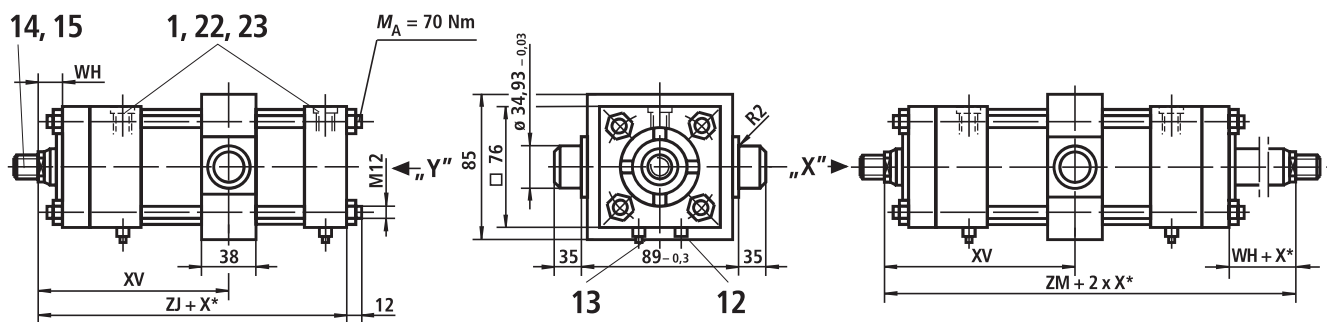

Stroke_{min} = 10 mm
Always specify dimension "XV"
in clear text on the order
(observe XV_{min} and XV_{max})

Note:
Dimensions for cylinder with piston rod
extension "LY" in the retracted
condition, see index 2 on page 5.

Stroke_{min} = 30 mm
with thread version "E"
(only for double-rod cylinder)

Type of mounting S Operating pressure 210 bar

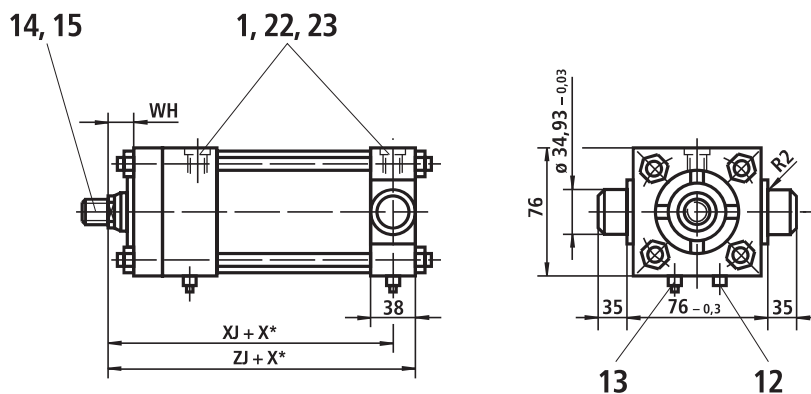

Piston rod Ø	KK			A		EE				D1			
	Thread version			Thread version		Pipe connection				Pipe connection			
	C, E	B	F	C, E, B	F	01	13	02	14	01	13	02	14
22	M16 x 1.5	M20 x 1.5	M20 x 1.5	28	45	G1/2	G3/4	M22 x 1.5	M27 x 2	34	42	34	42
25	M20 x 1.5	M22 x 1.5	M20 x 1.5	28	45								
36	M26 x 1.5	M30 x 2	M24 x 2	41	55								

X* = stroke length

Piston Ø 50 (dimensions in mm)

For explanations of items, see page 7

Type of mounting F Operating pressure 210 bar

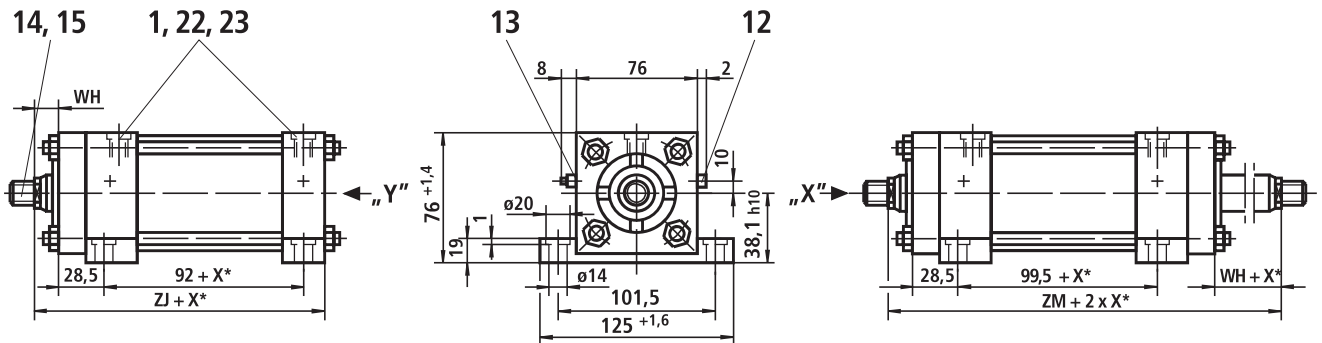

Stroke_{min} = 30 mm with thread version "E"
(only for double-rod cylinder)

Type of mounting L Operating pressure 210 bar

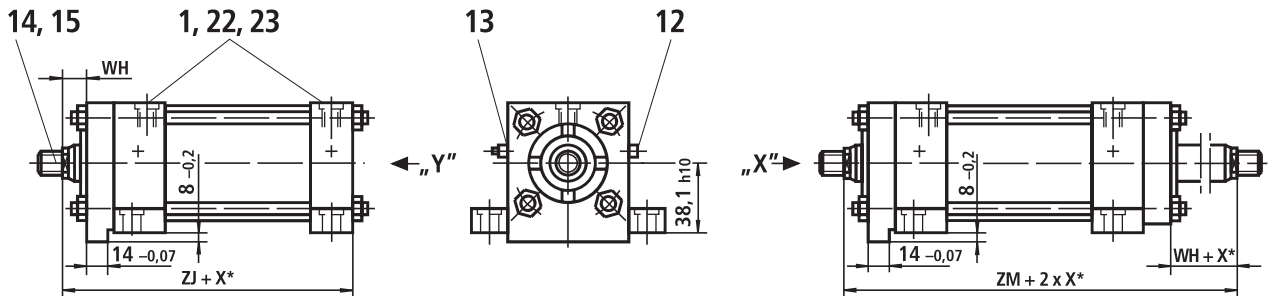

Stroke_{min} = 30 mm with thread version "E"
(only for double-rod cylinder)

Type of mounting M Operating pressure 210 bar

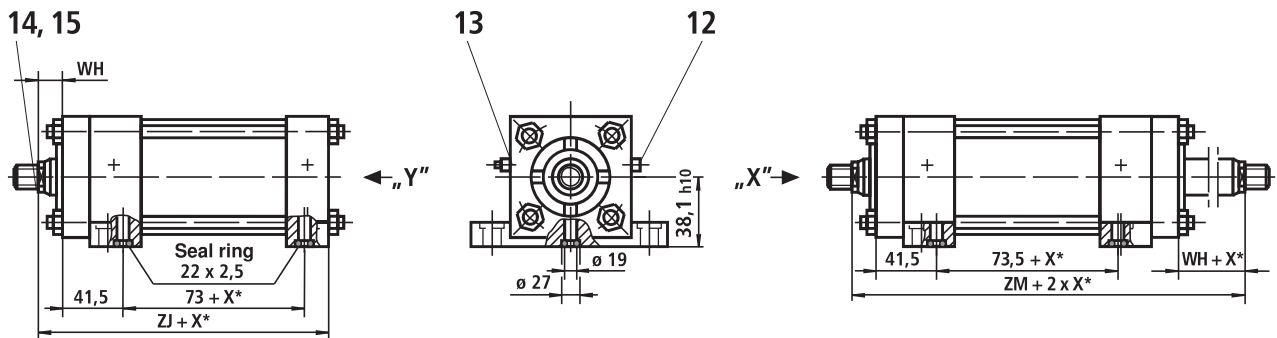

Stroke_{min} = 30 mm with thread version "E"
(only for double-rod cylinder)

Piston rod Ø	ØRD f7	VD	WH	XG	XJ	XV ¹⁾ min.	XV ¹⁾ max.	ZJ	ZM	B3	SW1	Cushioning lengths	
												piston side	piston rod side
22	38	6	19	57	133.5	99	95 + X*	152.5	194.5	8	19	30	30
25	38	7	19	57	133.5	99	95 + X*	152.5	194.5	8	22		
36	50	10	25.5	63.5	140	105.5	102 + X*	159	207.5	8	30		

X* = stroke length

¹⁾ Always specify dimension "XV" in clear text on the order (observe XV_{min} and XV_{max})

Piston Ø 50 (dimensions in mm)

For explanations of items, see page 7

Type of mounting Q Operating pressure 210 bar

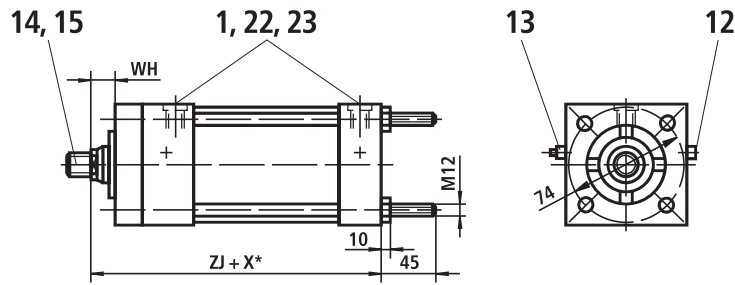

Additional thread versions

Thread version "E"

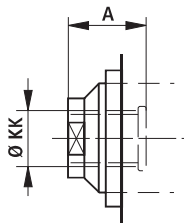

Thread version "F"

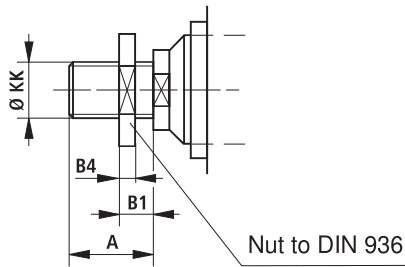

Self-aligning clevis CGK 20

suitable for thread version "F"

Material no.: **R900001329**

Weight: 0.34 kg

Permissible load: 30 kN

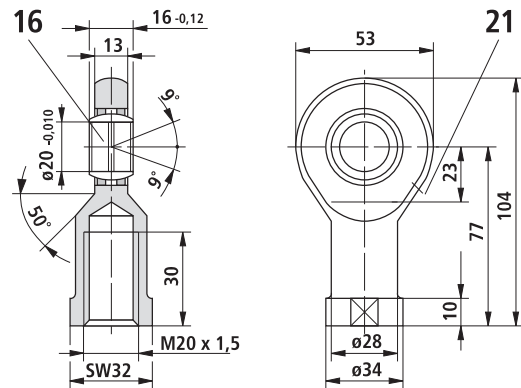

Self-aligning clevis CGK 25

suitable for thread version "F"

Material no.: **R900001330**

Weight: 0.6 kg

Permissible load: 42 kN

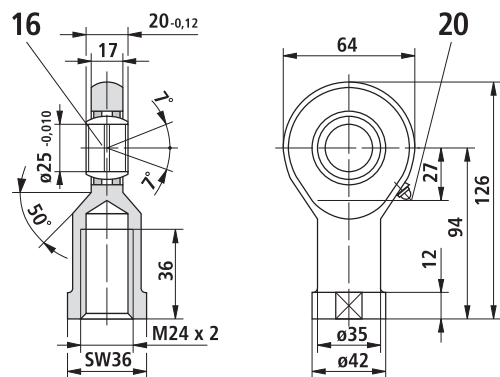

Piston rod Ø	ØRD f7	B4	VD	WH	ZJ	ZM	B1	B2	B3	SW1	Cushioning lengths	
											piston side	piston rod side
22	38	9	6	19	152.5	194.5	15	16	8	19	30	30
25	38	9	7	19	152.5	194.5	15	16	8	22		
36	50	10	10	25.5	159	207.5	19	12	8	30		

X* = stroke length

Piston Ø 63 (dimensions in mm)

For explanations of items, see page 7

Type of mounting H Operating pressure 210 bar

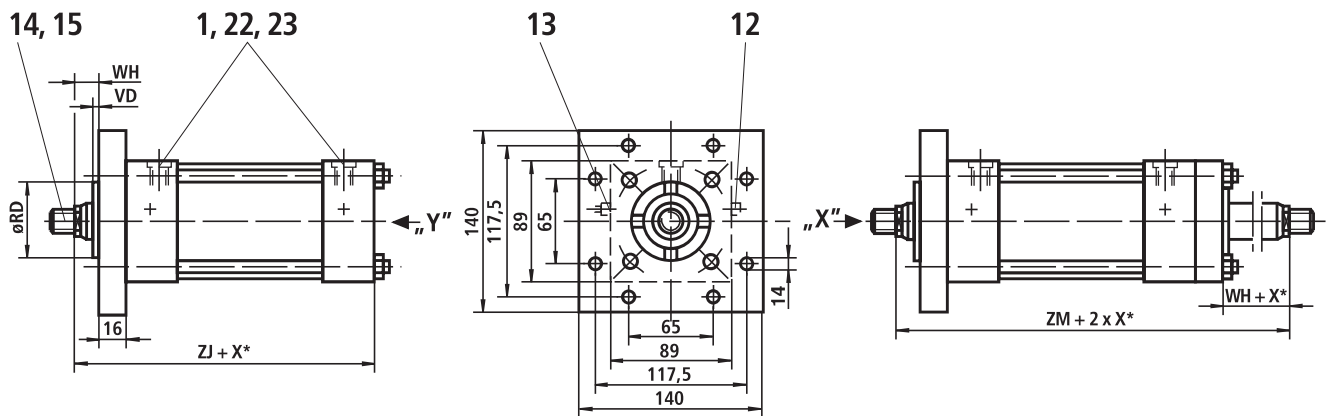

Stroke_{min} = 30 mm with thread version "E"
(only for double-rod cylinder)

Type of mounting D Operating pressure 210 bar

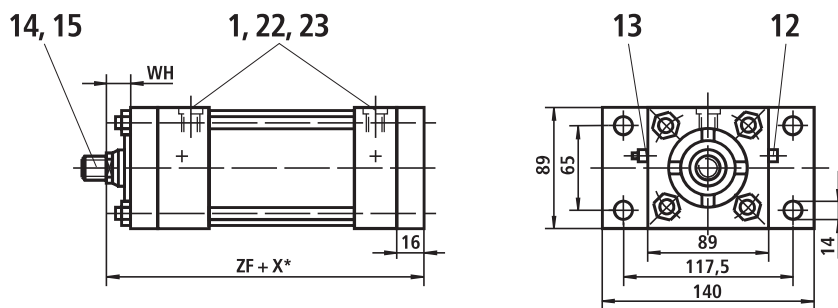

Type of mounting K Operating pressure 210 bar

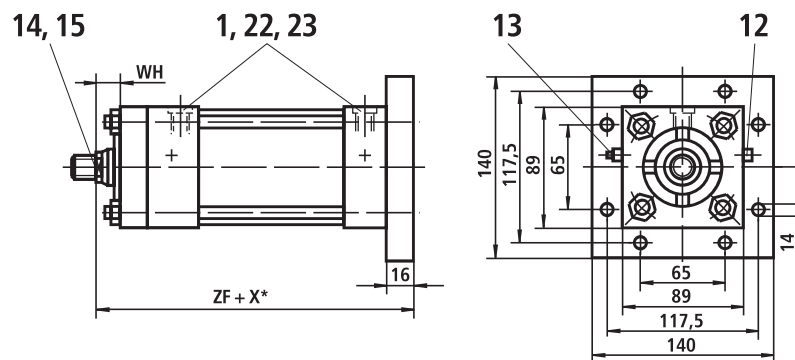

Piston rod Ø	ØRD f7	VD	WH	XC	XN	ZF	ZJ	ZM	B3	SW1	Cushioning lengths	
											piston side	piston rod side
25	38	6	19	187	225.5	171.5	155.5	197.5	8	22	30	30
28	42	6	19	187	225.5	171.5	155.5	197.5	8	22		
36	50.7	10	25.5	193.5	232	178	162	210.5	10	30		
45	60	13	32	200	238.5	184.5	168.5	223.5	12	41		

X* = stroke length

Piston Ø 63 (dimensions in mm)

For explanations of items, see page 7

Type of mounting R Operating pressure 210 bar

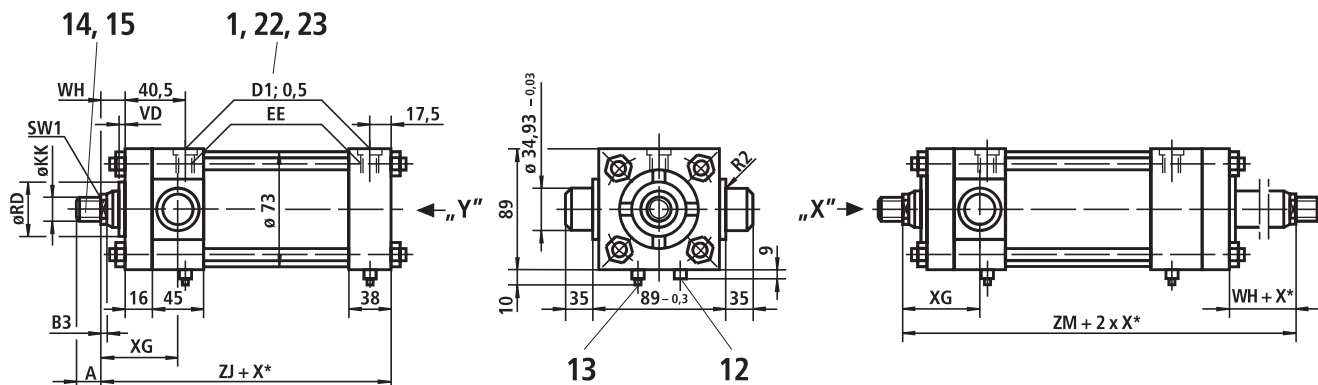

Stroke_{min} = 30 mm with thread version "E"
(only for double-rod cylinder)

Type of mounting E Operating pressure 210 bar

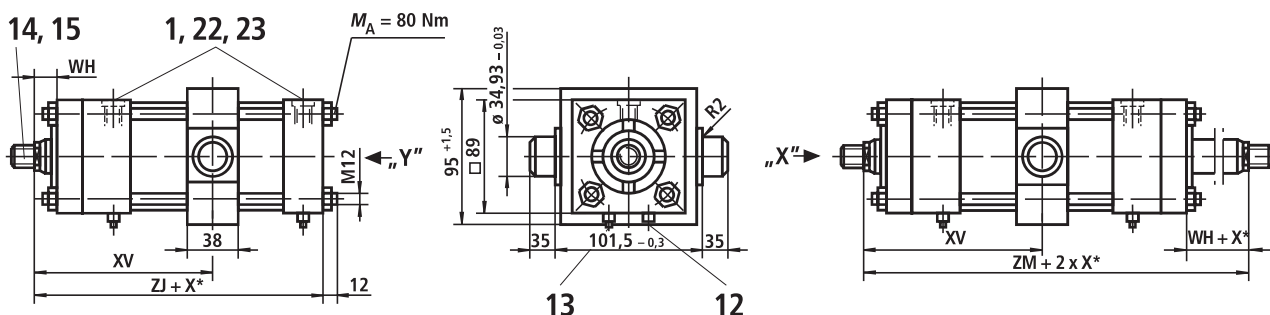

Stroke_{min} = 10 mm
Always specify dimension "XV"
in clear text on the order
(observe XV_{min} and XV_{max})

Note:
Dimensions for cylinder with piston rod
extension "LY" in the retracted
condition, see index 2 on page 5.

Stroke_{min} = 30 mm
with thread version "E"
(only for double-rod cylinder)

Type of mounting S Operating pressure 210 bar

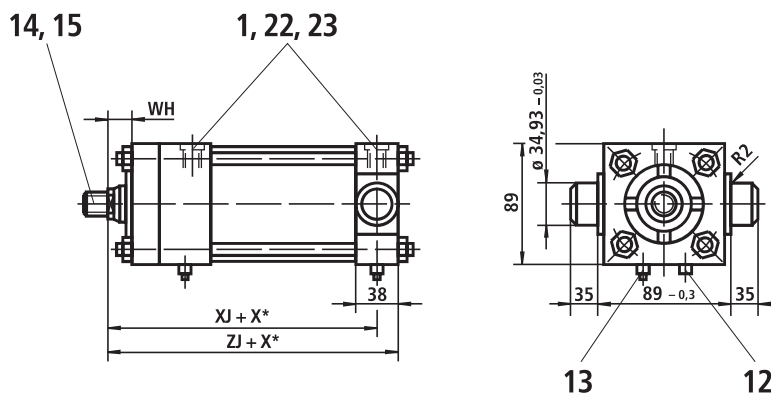

Piston rod Ø	KK			A		EE				D1			
	Thread version			Thread version		Pipe connection				Pipe connection			
	C, E	B	F	C, E, B	F	01	13	02	14	01	13	02	14
25	M20 x 1.5	M22 x 1.5	M24 x 2	28	55	G1/2	G3/4	M22 x 1.5	M27 x 2	34	42	34	42
28	M20 x 1.5	M22 x 1.5	M24 x 2	28	55								
36	M26 x 1.5	M30 x 2	M30 x 2	41	65								
45	M33 x 2	M39 x 2	M30 x 2	50	65								

X* = stroke length

Piston Ø 63 (dimensions in mm)

For explanations of items, see page 7

Type of mounting F Operating pressure 210 bar

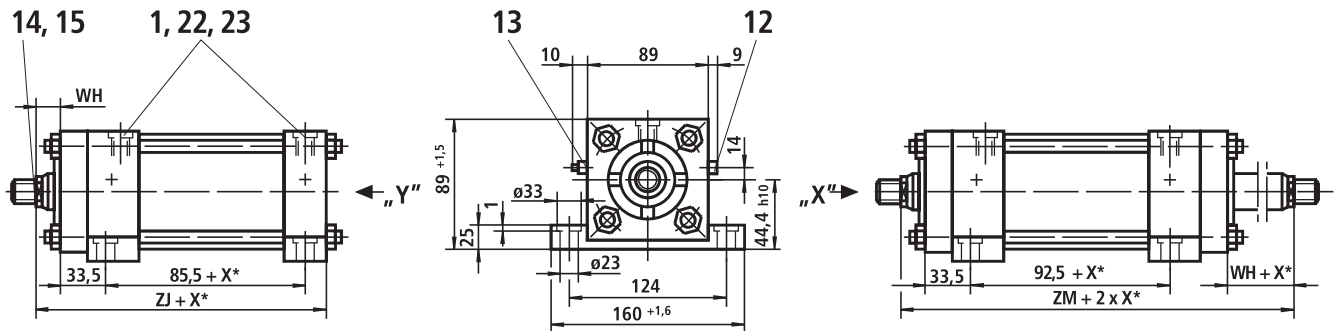

Stroke_{min} = 30 mm with thread version "E"
(only for double-rod cylinder)

Type of mounting L Operating pressure 210 bar

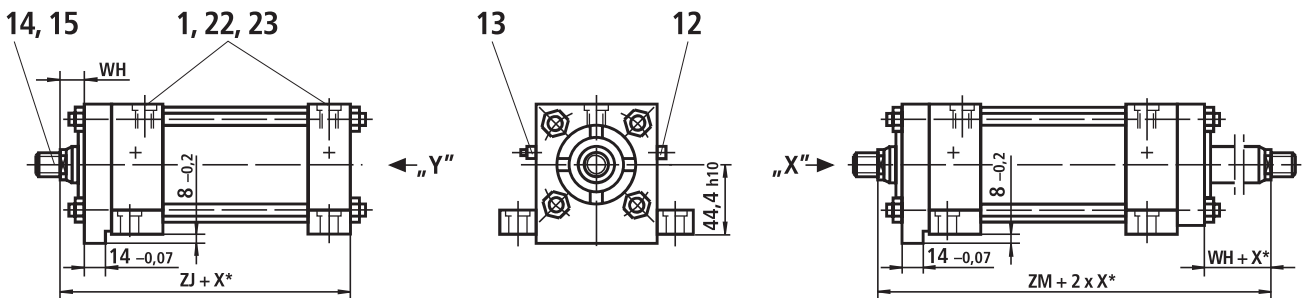

Stroke_{min} = 30 mm with thread version "E"
(only for double-rod cylinder)

Type of mounting M Operating pressure 210 bar

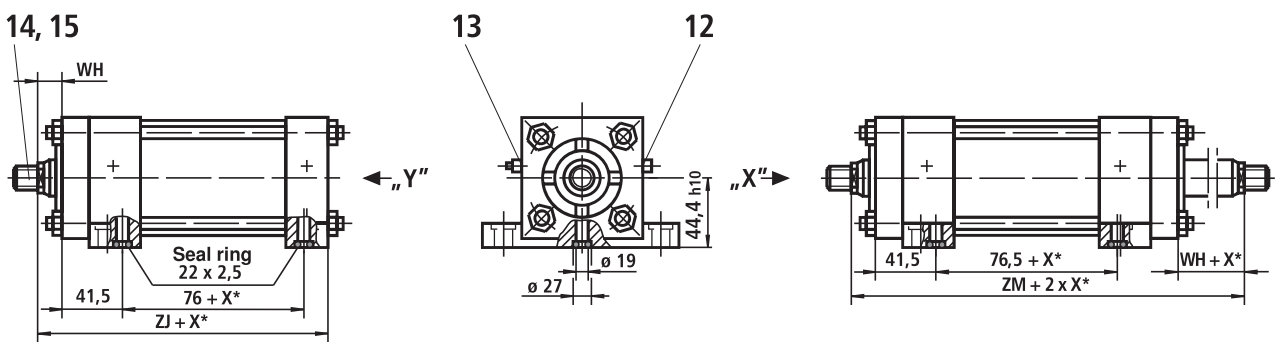

Stroke_{min} = 30 mm with thread version "E"
(only for double-rod cylinder)

Piston rod Ø	ØRD f7	VD	WH	XG	XJ	XV ¹⁾ min.	XV ¹⁾ max.	ZJ	ZM	B3	SW1	Cushioning lengths	
												piston side	piston rod side
25	38	6	19	57	136.5	99	98.5 + X*	155.5	197.5	8	22	30	30
28	42	6	19	57	136.5	99	98.5 + X*	155.5	197.5	8	22		
36	50.7	10	25.5	3.5	143	105.5	105 + X*	162	210.5	10	30		
45	60	13	32	70	149.5	112	111.5 + X*	168.5	223.5	12	41		

X* = stroke length

¹⁾ Always specify dimension "XV" in clear text on the order (observe XV_{min} and XV_{max})

Piston Ø 63 (dimensions in mm)

For explanations of items, see page 7

Type of mounting **Q** Operating pressure 210 bar

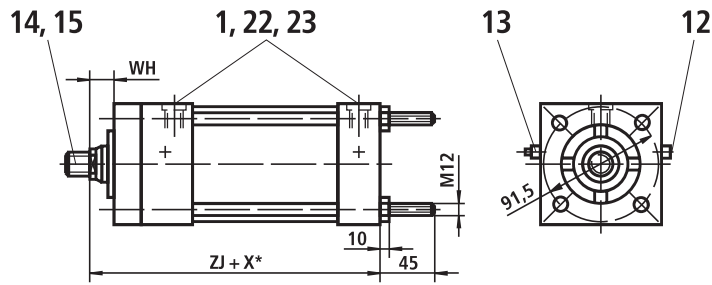

Additional thread versions

Thread version "E"

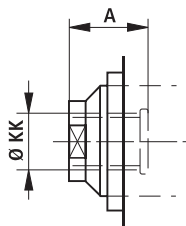

Thread version "F"

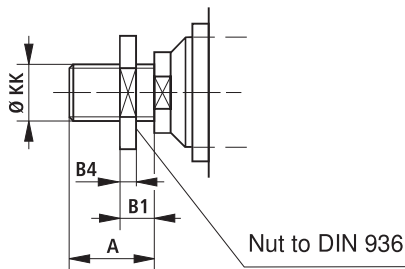

Self-aligning clevis CGK 25

suitable for thread version "F"
 Material no.: **R900001330**
 Weight: 0.6 kg
 Permissible load: 42 kN

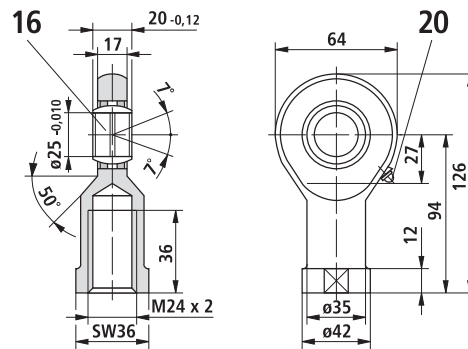

Self-aligning clevis CGK 30

suitable for thread version "F"
 Material no.: **R900001331**
 Weight: 0.9 kg
 Permissible load: 55 kN

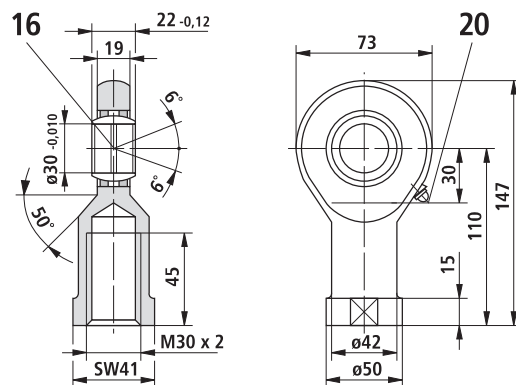

Piston rod Ø	ØRD f7	B4	VD	WH	ZJ	ZM	B1	B2	B3	SW1	Cushioning lengths	
											piston side	piston rod side
25	38	10	6	19	155.5	197.5	19	20	8	22	30	30
28	42	10	6	19	155.5	197.5	19	20	8	22		
36	50.7	12	10	25.5	162	210.5	20	14	10	30		
45	60	12	13	32	168.5	223.5	20	14	12	41		

X* = stroke length

Piston Ø 80 (dimensions in mm)

For explanations of items, see page 7

Type of mounting B Operating pressure 210 bar

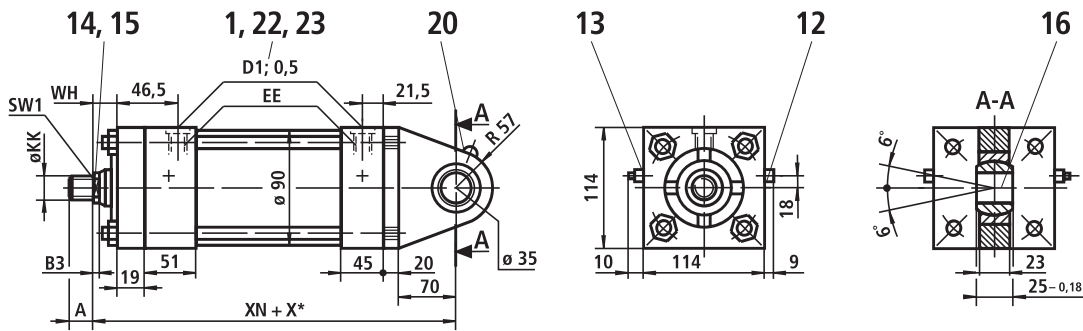

Type of mounting G Operating pressure 210 bar

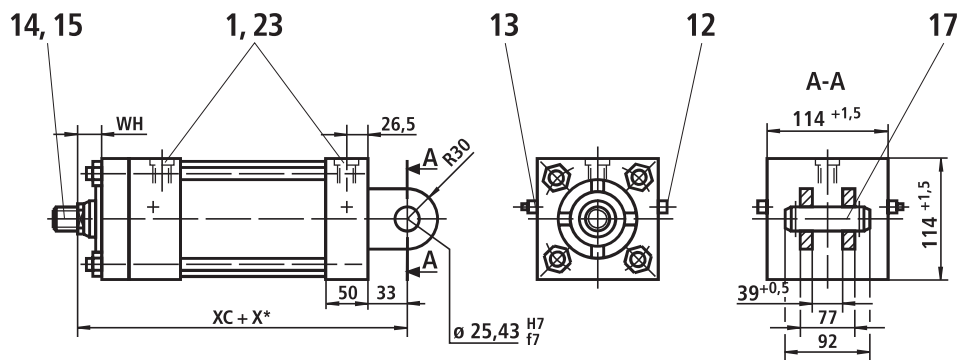

Type of mounting C Operating pressure with piston rod Ø 36: 180 bar on cap side, 210 bar on piston rod side
 Operating pressure with piston rod Ø 45 and Ø 56: 110 bar on cap side, 210 bar on piston rod side

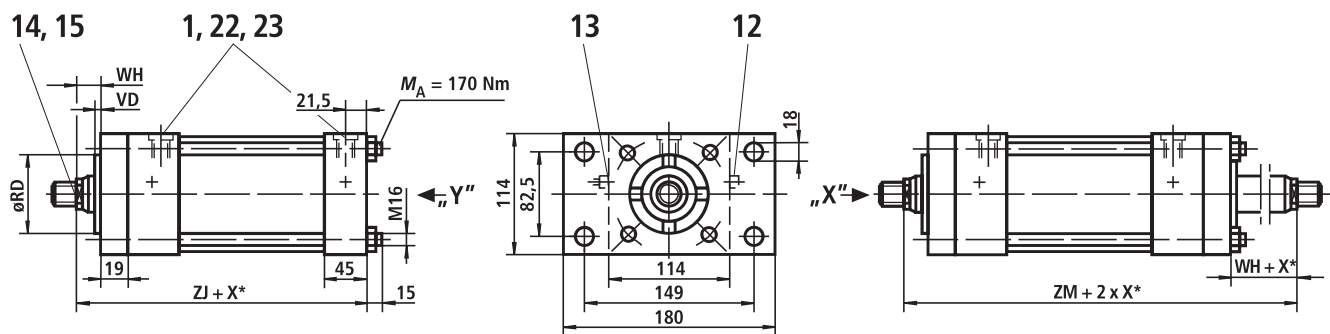

Stroke_{min} = 30 mm with thread version "E"
 (only for double-rod cylinder)

Piston rod Ø	KK			A		EE				D1			
	Thread version			Thread version		Pipe connection				Pipe connection			
	C, E	B	F	C, E, B	F	01	13	02	14	01	13	02	14
36	M26 x 1.5	M30 x 2	M30 x 2	41	65	G3/4	G1	M27 x 2	M33 x 2	42	47	42	47
45	M33 x 2	M39 x 2	M36 x 3	51	80					42	47	42	47
56	M39 x 2	M45 x 2	M39 x 3	57	90					42	47	42	47

X* = stroke length

Piston Ø 80 (dimensions in mm)

For explanations of items, see page 7

Type of mounting H Operating pressure 210 bar

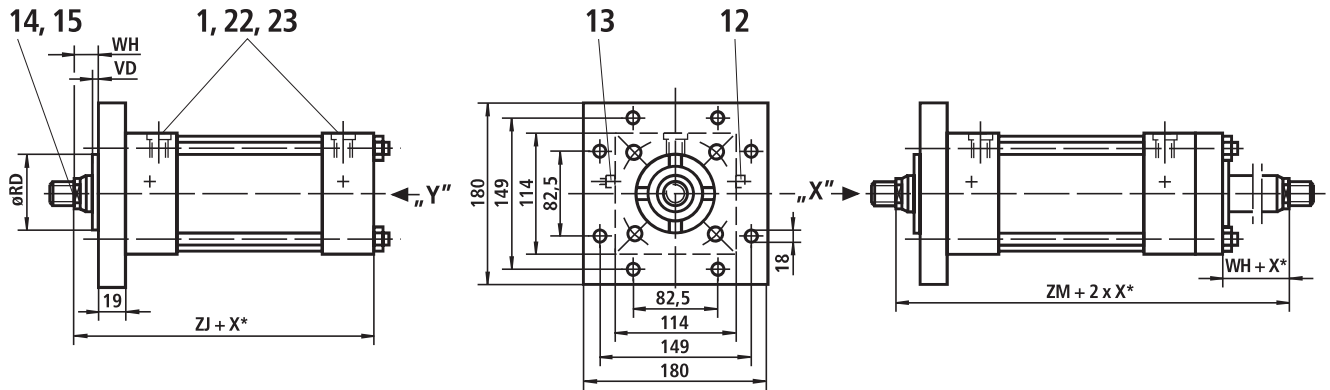

Stroke_{min} = 30 mm with thread version "E"
(only for double-rod cylinder)

Type of mounting D Operating pressure 210 bar

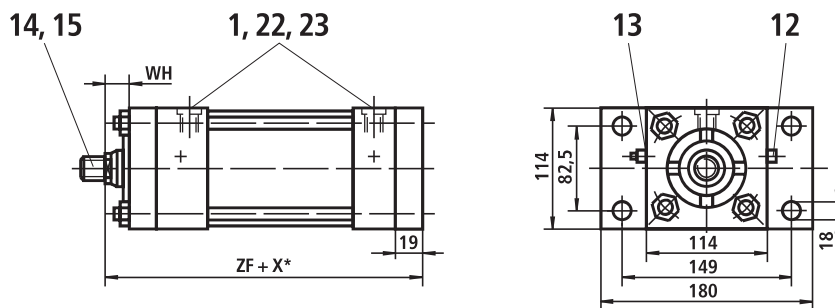

Type of mounting K Operating pressure 210 bar

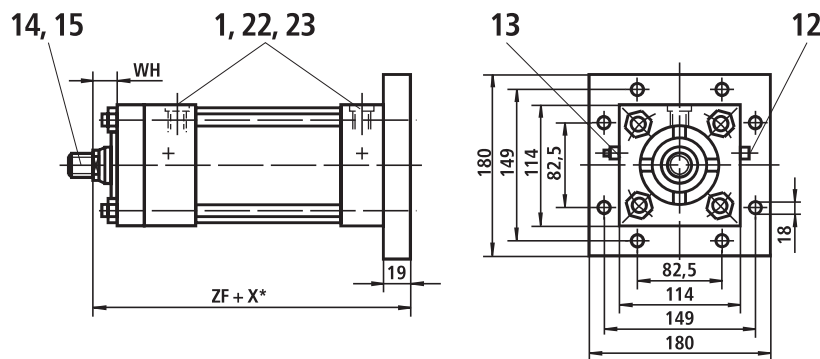

Piston rod Ø	ØRD f7	VD	WH	XC	XN	ZF	ZJ	ZM	B3	SW1	Cushioning lengths	
											piston side	piston rod side
36	50	6	22	219	271	200	181	228	9	30	35	35
45	60	10	28.5	225.5	277.5	206.5	187.5	241	12	41		
56	70	10	32	229	281	210	191	248	15	46		

X* = stroke length

Piston Ø 80 (dimensions in mm)

For explanations of items, see page 7

Type of mounting R Operating pressure 210 bar

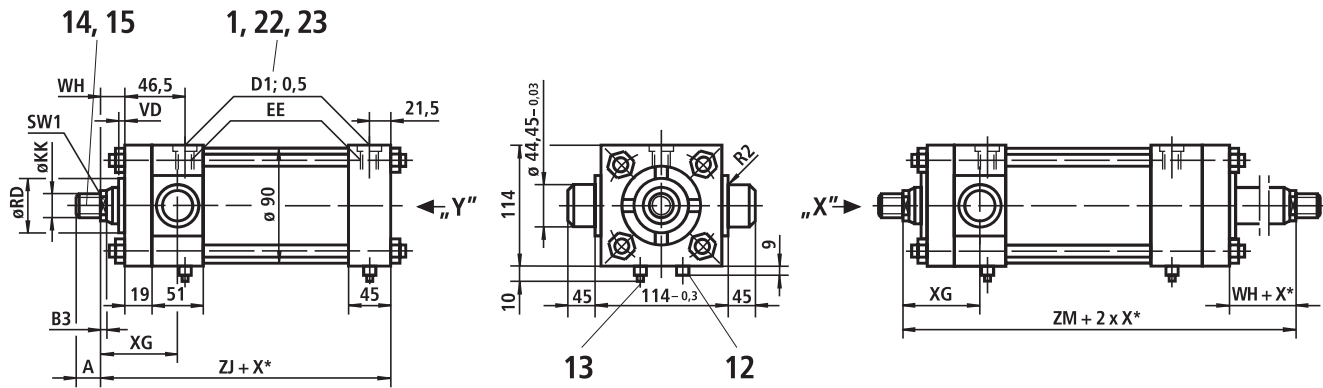

Stroke_{min} = 30 mm with thread version "E"
(only for double-rod cylinder)

Type of mounting E Operating pressure 210 bar

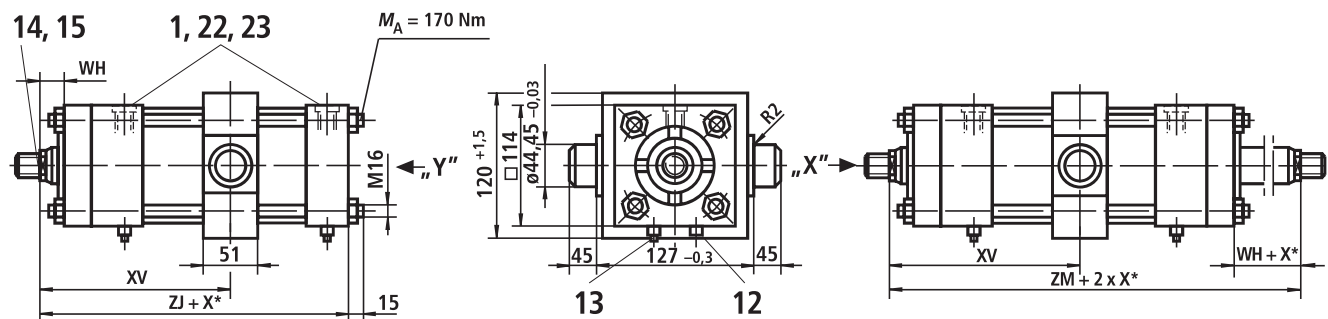

Stroke_{min} = 20 mm
Always specify dimension "XV"
in clear text on the order
(observe XV_{min} and XV_{max})

Note:
Dimensions for cylinder with piston rod
extension "LY" in the retracted
condition, see index 2 on page 5.

Stroke_{min} = 30 mm
with thread_{min} version "E"
(only for double-rod cylinder)

Type of mounting S Operating pressure 210 bar

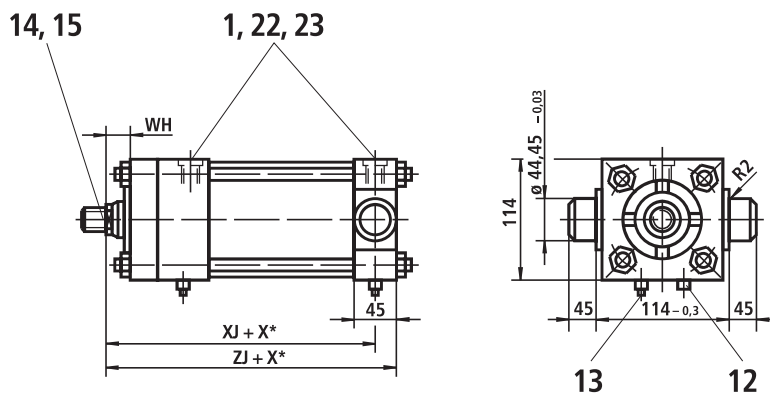

Piston rod Ø	KK			A		EE				D1			
	Thread version			Thread version		Pipe connection				Pipe connection			
	C, E	B	F	C, E, B	F	01	13	02	14	01	13	02	14
36	M26 x 1.5	M30 x 2	M30 x 2	41	65								
45	M33 x 2	M39 x 2	M36 x 3	51	80								
56	M39 x 2	M45 x 2	M39 x 3	57	90	G3/4	G1	M27 x 2	M33 x 2	42	47	42	47

X* = stroke length

Piston Ø 80 (dimensions in mm)

For explanations of items, see page 7

Type of mounting F Operating pressure 210 bar

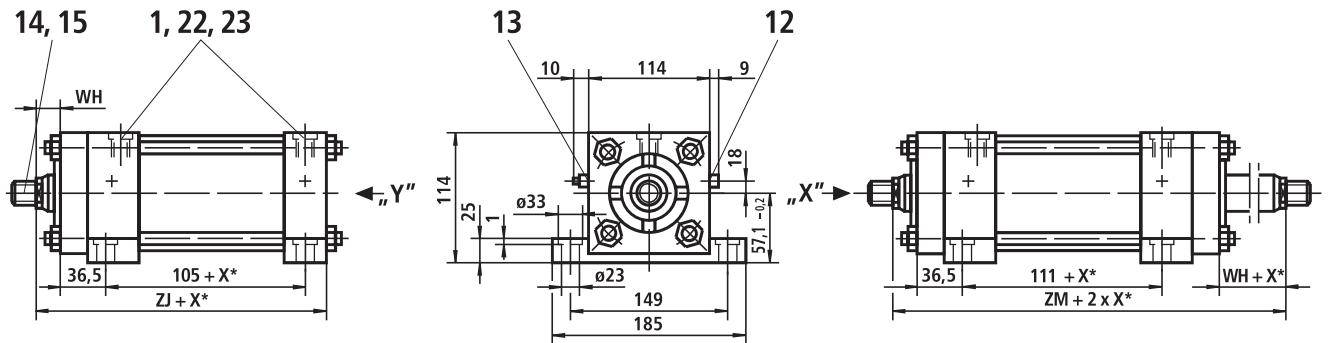

Stroke_{min} = 30 mm with thread version "E"
(only for double-rod cylinder)

Type of mounting L Operating pressure 210 bar

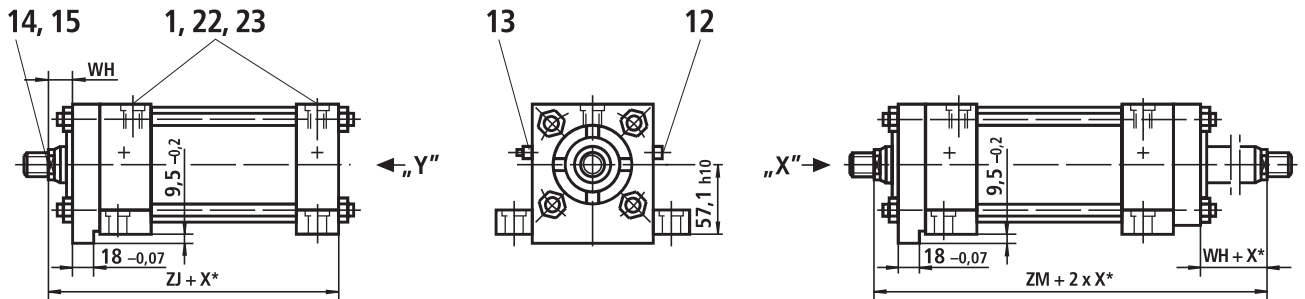

Stroke_{min} = 30 mm with thread version "E"
(only for double-rod cylinder)

Type of mounting M Operating pressure 210 bar

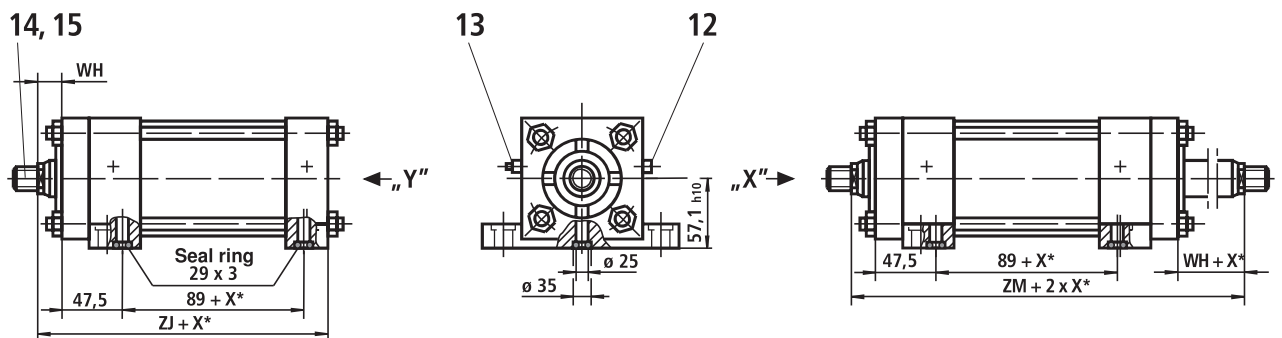

Stroke_{min} = 30 mm with thread version "E"
(only for double-rod cylinder)

Piston rod Ø	ØRD f7	VD	WH	XG	XJ	XV ¹⁾ min.	XV ¹⁾ max.	ZJ	ZM	B3	SW1	Cushioning lengths	
												piston side	on piston rod side
36	50	6	22	66.5	158.5	117.5	110.5 + X*	181	228	9	30	35	35
45	60	10	28.5	73	165	124	117 + X*	187.5	241	12	41		
56	70	10	32	76.5	168.5	127.5	120.5 + X*	191	248	15	46		

X* = stroke length

¹⁾ Always specify dimension "XV" in clear text on the order (observe XV_{min} and XV_{max})

Piston Ø 80 (dimensions in mm)

For explanations of items, see page 7

Type of mounting **Q** Operating pressure 210 bar

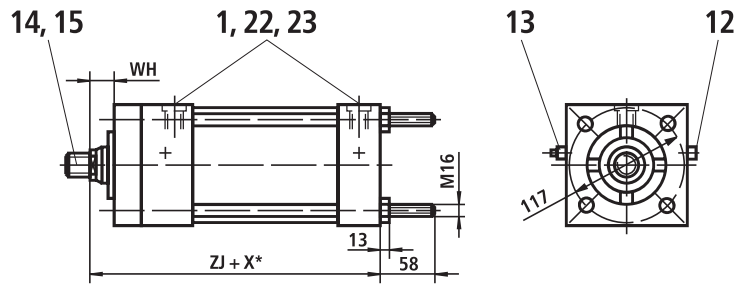

Additional thread versions

Thread version "E"

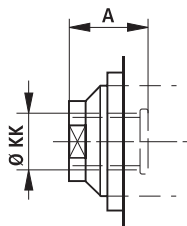

Self-aligning clevis CGK 30

suitable for thread version "F"
Material no.: **R900001331**
Weight: 0.9 kg
Permissible load: 55 kN

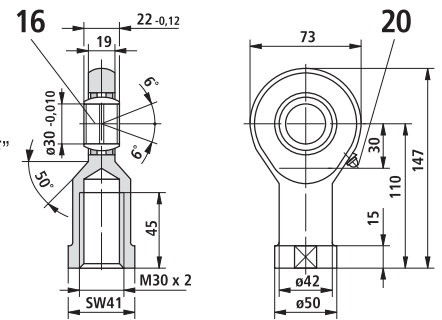

Thread version "F"

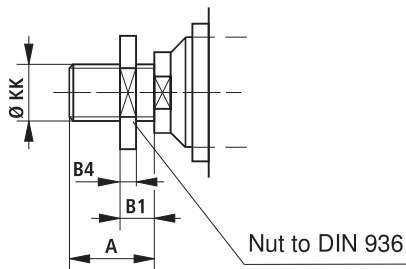

Self-aligning clevis CGK 35

suitable for thread version "F"
Material no.: **R900012486**
Weight: 1.4 kg
Permissible load: 73 kN

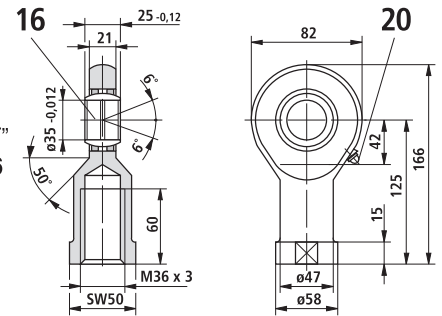

Self-aligning clevis CGK 40

suitable for thread version "F"
Material no.: **R900001332**
Weight: 2 kg
Permissible load: 90 kN

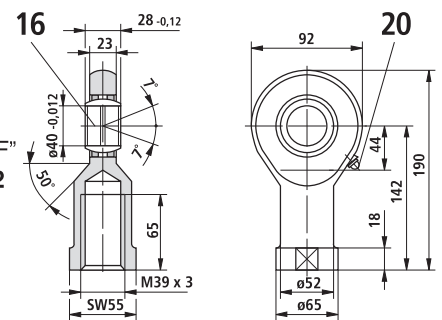

Piston rod Ø	ØRD f7	B4	VD	WH	ZJ	ZM	B1	B2	B3	SW1	Cushioning lengths	
											piston side	piston rod side
36	50	12	6	22	181	228	20	20	9	30	35	35
45	60	14	10	28.5	187.5	241	20	15	12	41		
56	70	16	10	32	191	248	25	15	15	46		

X* = stroke length

Piston Ø 100 (dimensions in mm)

For explanations of items, see page 7

Type of mounting H Operating pressure 210 bar

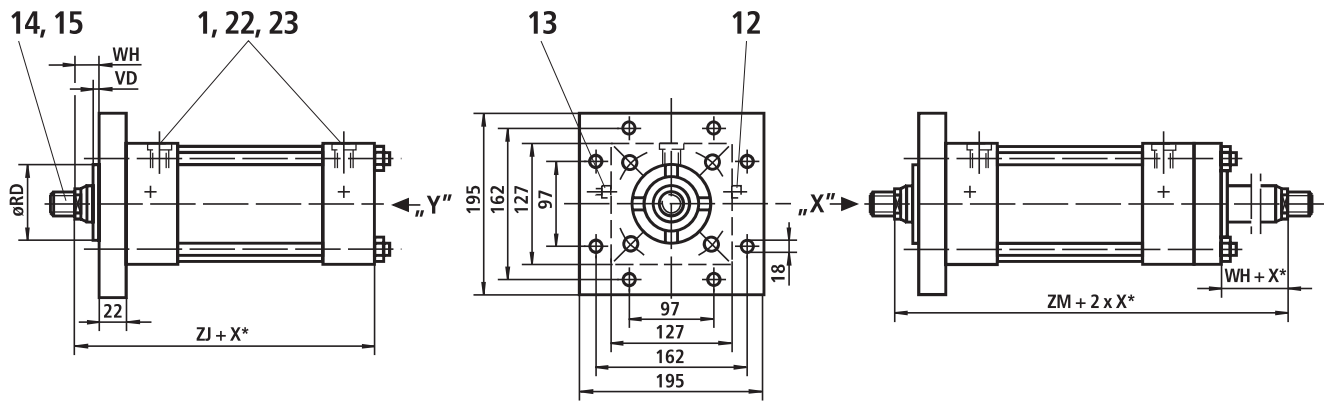

Stroke_{min} = 55 mm with thread version "E"
(only for double-rod cylinder)

Type of mounting D Operating pressure 210 bar

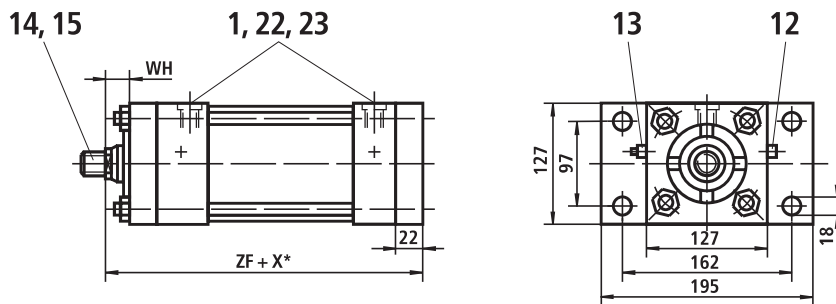

Type of mounting K Operating pressure 210 bar

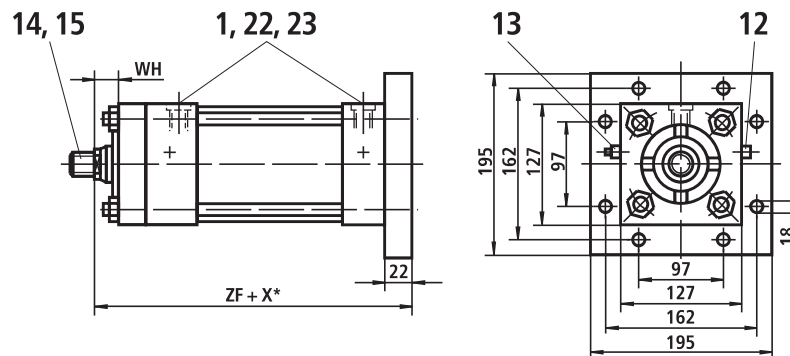

Piston rod Ø	ØRD f7	VD	WH	XC	XN	ZF	ZJ	ZM	B3	SW1	Cushioning lengths	
											piston side	piston rod side
45	60	6	25.5	248	294	216	194	247.5	12	41	35	35
50	66.6	6	28.5	251	297	219	197	253.5	15	46		
70	90	10	35	257.5	303.5	225.5	203.5	266.5	15	60		

X* = stroke length

Piston Ø 100 (dimensions in mm)

For explanations of items, see page 7

Type of mounting R Operating pressure 210 bar

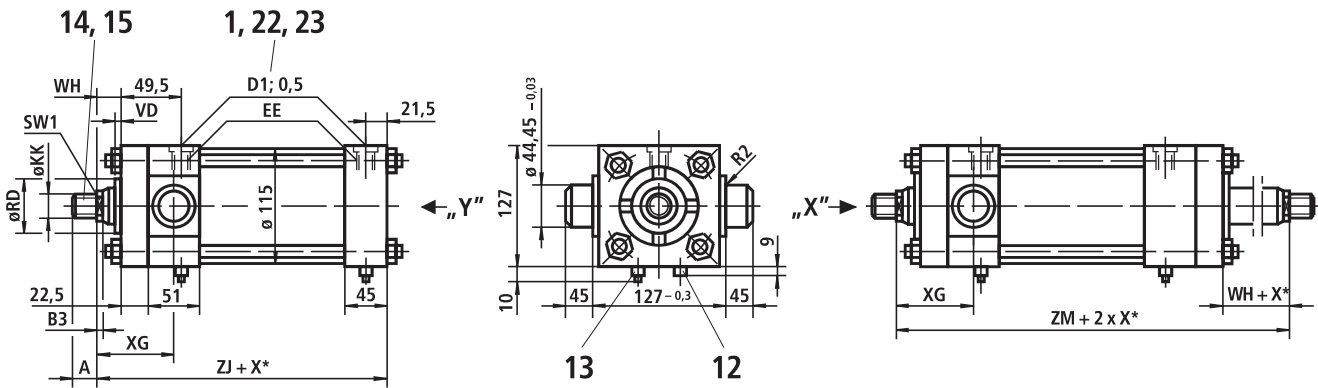

Stroke_{min} = 55 mm with thread version "E"
(only for double-rod cylinder)

Type of mounting E Operating pressure 210 bar

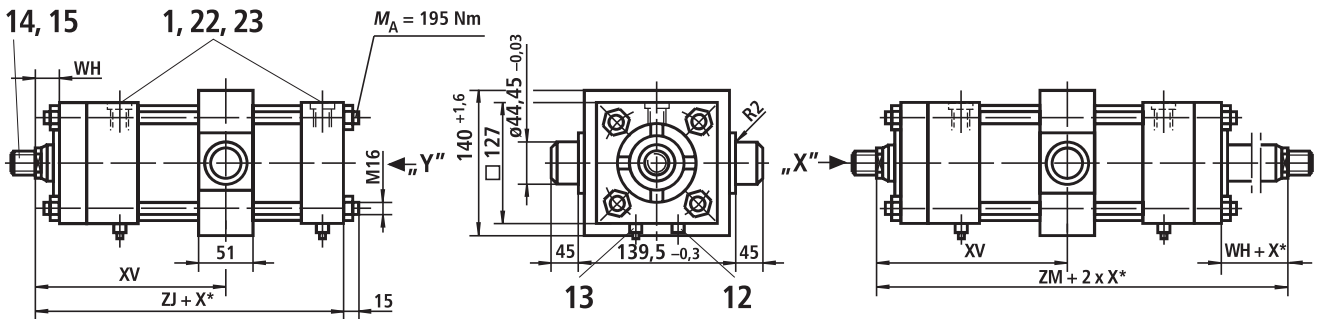

Stroke_{min} = 20 mm
Always specify dimension "XV"
in clear text on the order
(observe XV_{min} and XV_{max})

Note:
Dimensions for cylinder with piston rod
extension "LY" in the retracted
condition, see index 2 on page 5.

Stroke_{min} = 55 mm
with thread version "E"
(only for double-rod cylinder)

Type of mounting S Operating pressure 210 bar

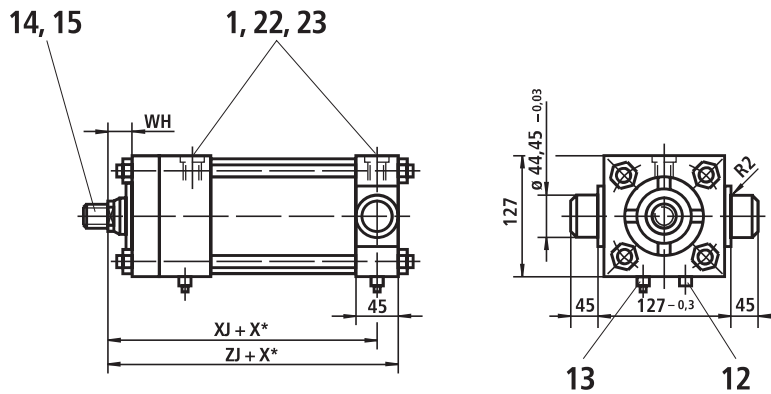

Piston rod Ø	KK			A		EE				D1			
	Thread version			Thread version		Pipe connection				Pipe connection			
	C, E	B	F	C, E, B	F	01	13	02	14	01	13	02	14
45	M33 x 2	M39 x 2	M42 x 3	51	90	G3/4	G1	M27 x 2	M33 x 2	42	47	42	47
50	M39 x 2	M45 x 2	M45 x 3	57	100					42	47	42	47
70	M48 x 2	M56 x 2	M45 x 3	76	100					42	47	42	47

X* = stroke length

Piston Ø 100 (dimensions in mm)

For explanations of items, see page 7

Type of mounting F Operating pressure 210 bar

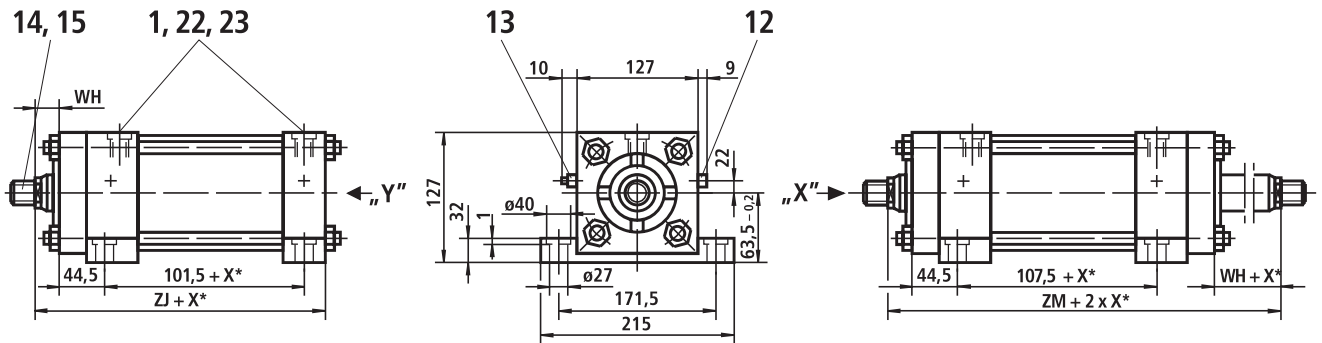

Stroke_{min} = 55 mm with thread version "E"
(only for double-rod cylinder)

Type of mounting L Operating pressure 210 bar

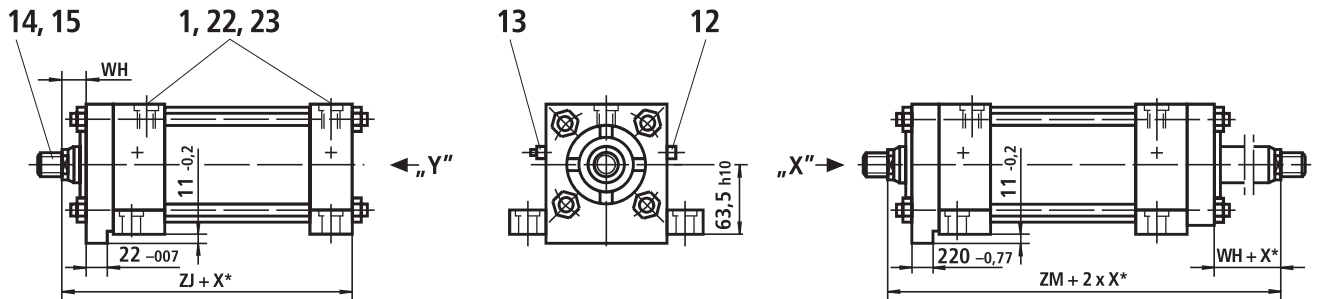

Stroke_{min} = 55 mm with thread version "E"
(only for double-rod cylinder)

Type of mounting M Operating pressure 210 bar

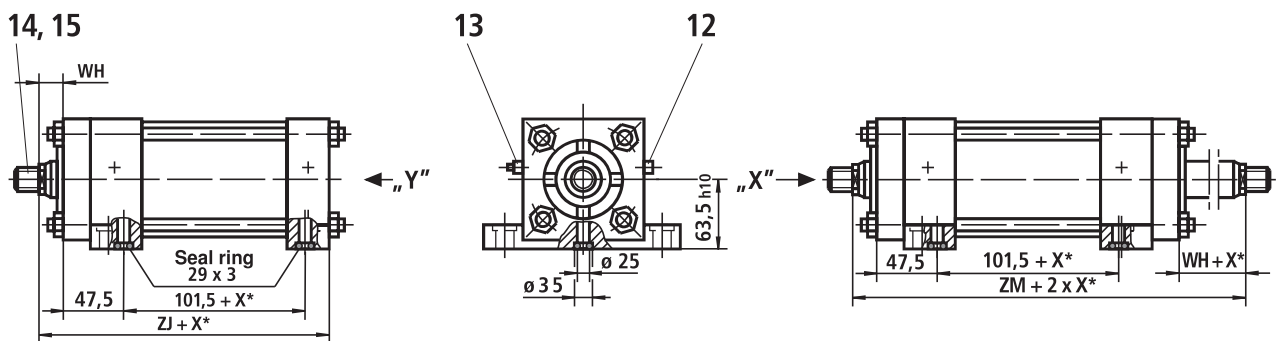

Stroke_{min} = 55 mm with thread version "E"
(only for double-rod cylinder)

Piston rod Ø	ØRD f7	VD	WH	XG	XJ	XV ¹⁾ min.	XV ¹⁾ max.	ZJ	ZM	B3	SW1	Cushioning lengths	
												piston side	piston rod side
45	60	6	25.5	73	171.5	124.5	123.5 + X*	194	247.5	12	41	35	35
50	66.6	6	28.5	76	174.5	127.5	126.5 + X*	197	253.5	15	46		
70	90	10	35	82.5	181	134	133 + X*	203.5	266.5	15	60		

X* = stroke length

¹⁾ Always specify dimension "XV" in clear text on the order (observe XV_{min} and XV_{max})

Piston Ø 100 (dimensions in mm)

For explanations of items, see page 7

Type of mounting N Operating pressure 210 bar

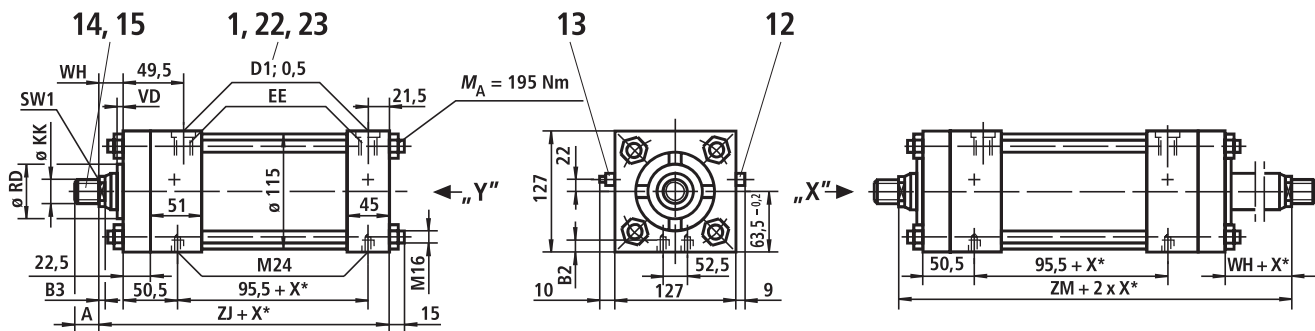

Stroke_{min} = 55 mm with thread version "E"
(only for double-rod cylinder)

Type of mounting T Operating pressure 210 bar

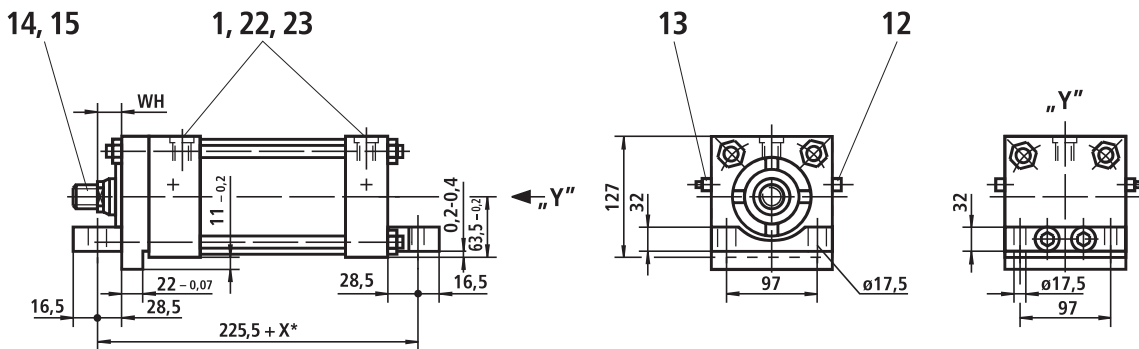

Type of mounting P Operating pressure 210 bar

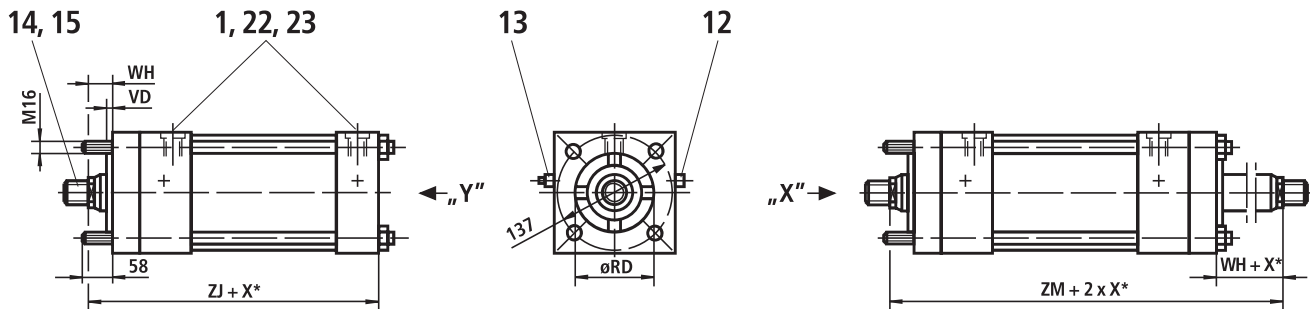

Stroke_{min} = 55 mm with thread version "E"
(only for double-rod cylinder)

Piston rod Ø	KK			A		EE				D1			
	Thread version			Thread version		Pipe connection				Pipe connection			
	C, E	B	F	C, E, B	F	01	13	02	14	01	13	02	14
45	M33 x 2	M39 x 2	M42 x 3	51	90	G3/4	G1	M27 x 2	M33 x 2	42	47	42	47
50	M39 x 2	M45 x 2	M45 x 3	57	100					42	47	42	47
70	M48 x 2	M56 x 2	M45 x 3	76	100					42	47	42	47

X* = stroke length

Piston Ø 100 (dimensions in mm)

For explanations of items, see page 7

Type of mounting **Q** Operating pressure 210 bar

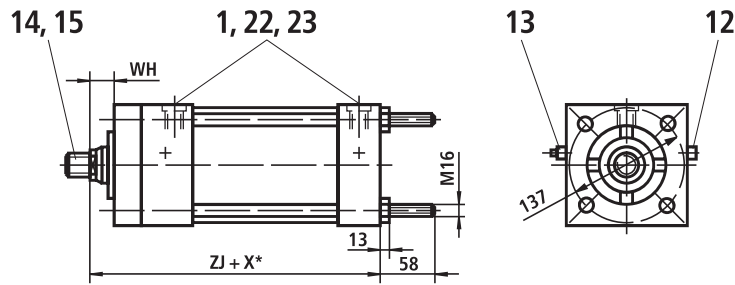

Additional thread versions

Thread version "E"

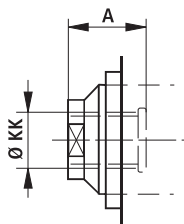

Thread version "F"

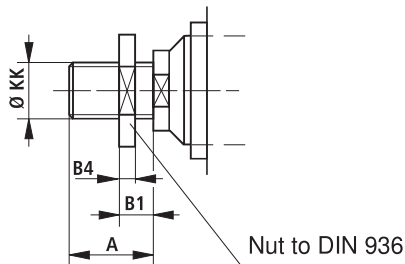

Self-aligning clevis CGK 45

suitable for thread version "F"
 Material no.: **R900001333**
 Weight: 2.7 kg
 Permissible load: 120 kN

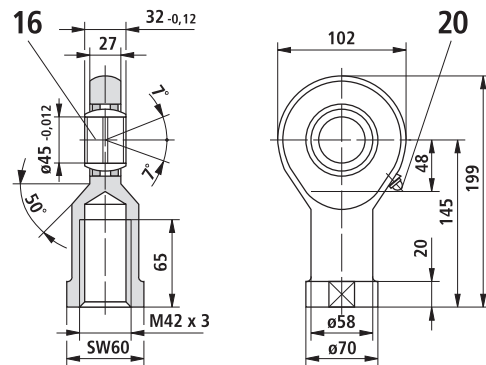

Self-aligning clevis CGK 50

suitable for thread version "F"
 Material no.: **R900001334**
 Weight: 3.5 kg
 Permissible load: 145 kN

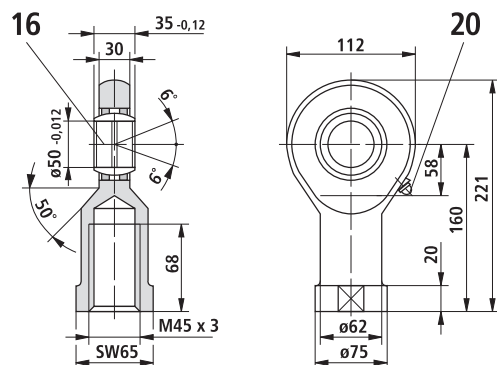

Piston rod Ø	ØRD f7	B4	VD	WH	ZJ	ZM	B1	B2	B3	SW1	Cushioning lengths	
											piston side	piston rod side
45	60	16	6	25.5	194	247.5	25	25	12	41	35	35
50	66.6	18	6	28.5	197	253.5	32	25	15	46		
70	90	18	10	35	203.5	266.5	32	15	15	60		

X* = stroke length

Piston Ø 125 (dimensions in mm)

For explanations of items, see page 7

Type of mounting H Operating pressure 210 bar

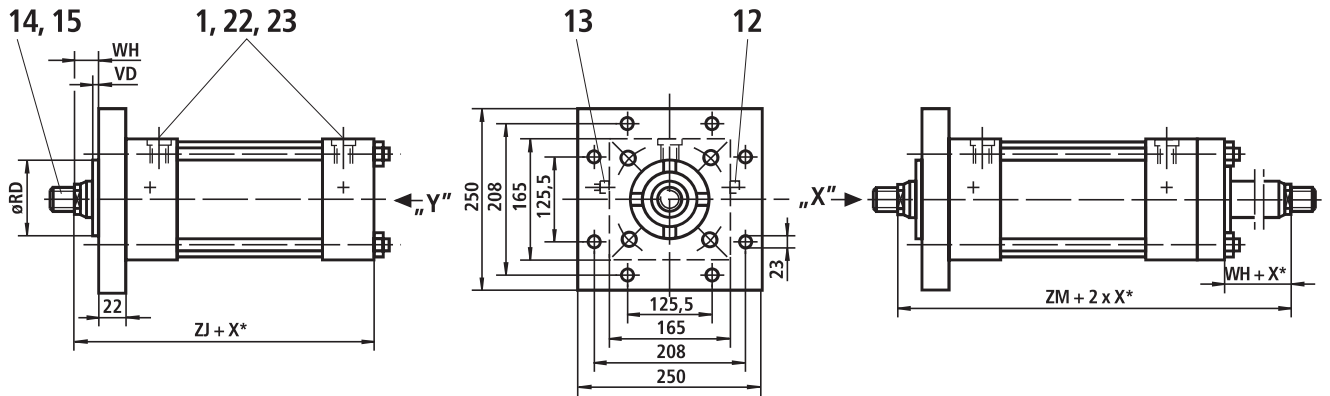

Stroke_{min} = 70 mm with thread version "E"
(only for double-rod cylinder)

Type of mounting D Operating pressure with piston rod Ø 50, 56 and Ø 63: 210 bar on cap side, 150 bar on piston rod side
Operating pressure with piston rod Ø 90: 210 bar on cap side, 210 bar on piston rod side

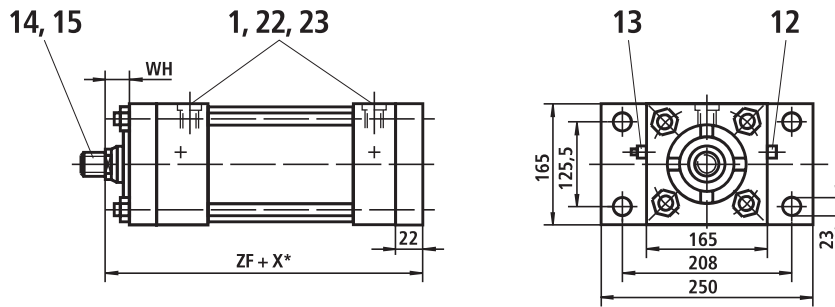

Type of mounting K Operating pressure 210 bar

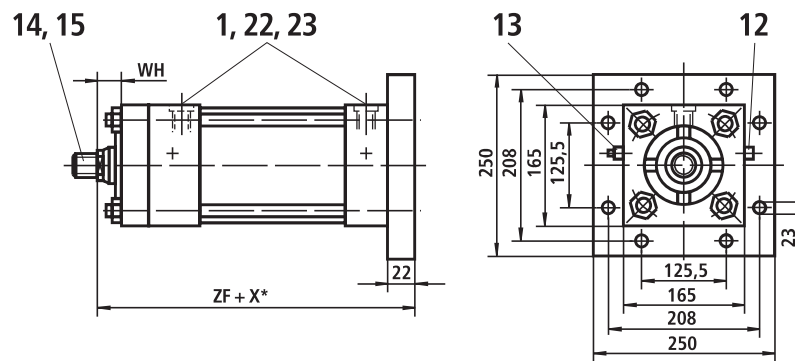

Piston rod Ø	ØRD f7	VD	WH	XC	XN	ZF	ZJ	ZM	B3	SW1	Cushioning lengths	
											piston side	piston rod side
50	66.6	6	28.5	266.5	329.5	231.5	209.5	266	14	46	33	35
56	70	7	28.5	266.5	329.5	231.5	209.5	266	14	46		
63	79.3	10	35	273	336	238	216	279	15	55		
90	108	10	35	273	336	238	216	279	15	75		

X* = stroke length

Piston Ø 125 (dimensions in mm)

For explanations of items, see page 7

Type of mounting R Operating pressure 210 bar

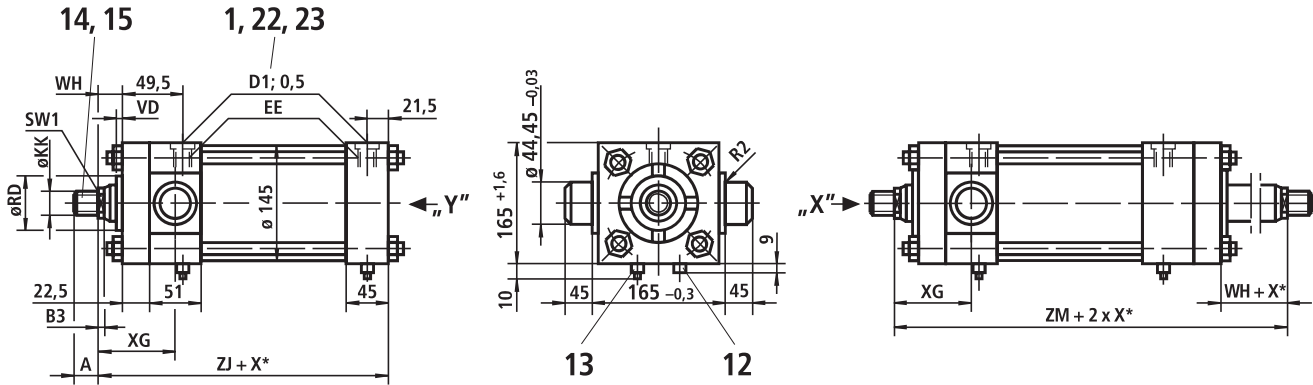

Stroke_{min} = 70 mm with thread version "E"
(only for double-rod cylinder)

Type of mounting E Operating pressure 210 bar

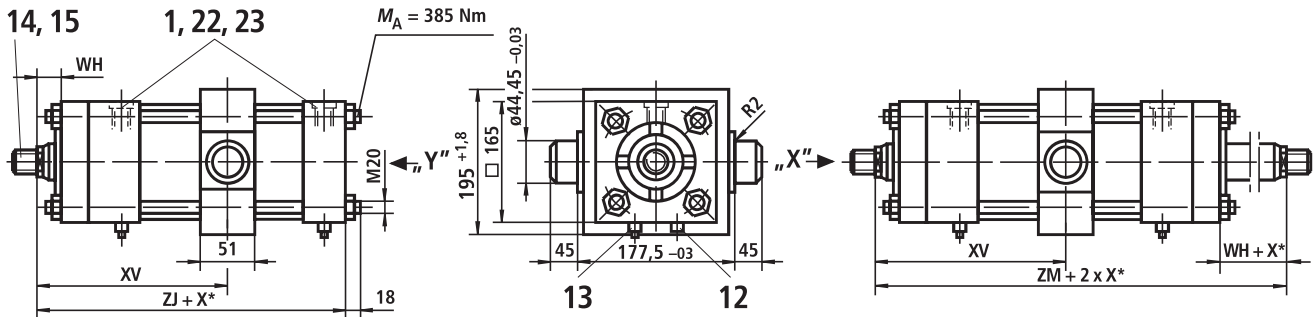

Stroke_{min} = 20 mm
Always specify dimension "XV"
in clear text on the order
(observe XV_{min} and XV_{max})

Note:
Dimensions for cylinder with piston rod
extension "LY" in the retracted
condition, see index 2 on page 5.

Stroke_{min} = 70 mm
with thread version "E"
(only for double-rod cylinder)

Type of mounting S Operating pressure 210 bar

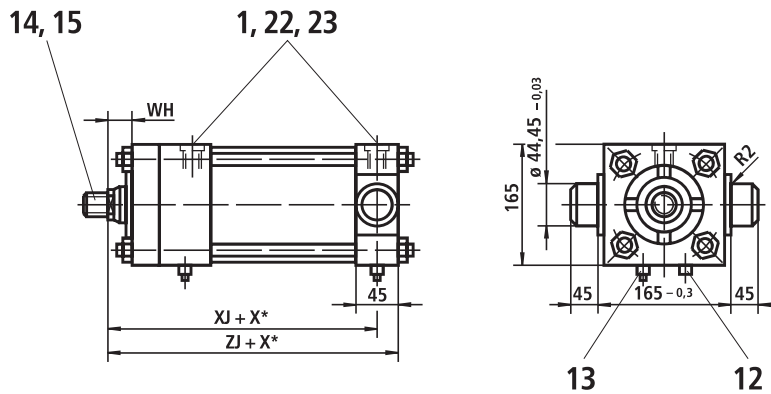

Piston rod Ø	KK			A		EE				D1			
	Thread version			Thread version		Pipe connection				Pipe connection			
	C, E	B	F	C, E, B	F	01	13	02	14	01	13	02	14
50	M39 x 2	M45 x 2	M45 x 3	57	100	G3/4	G1	M27 x 2	M33 x 2	42	47	42	47
56	M39 x 2	M45 x 2	M45 x 3	57	100								
63	M48 x 2	M56 x 2	M52 x 3	76	115								
90	M64 x 2	M76 x 2	M52 x 3	89	115								

X* = stroke length

Piston Ø 125 (dimensions in mm)

For explanations of items, see page 7

Type of mounting F Operating pressure 210 bar

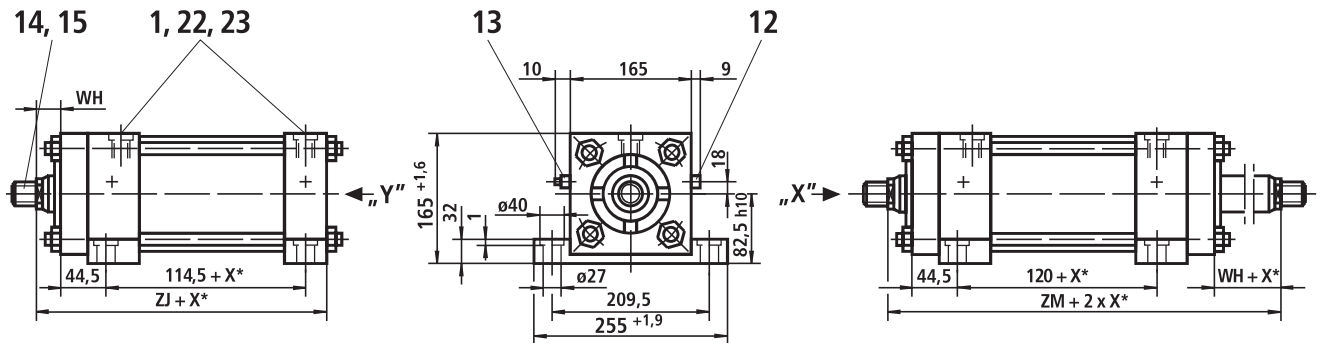

Stroke_{min} = 70 mm with thread version "E"
(only for double-rod cylinder)

Type of mounting L Operating pressure 210 bar

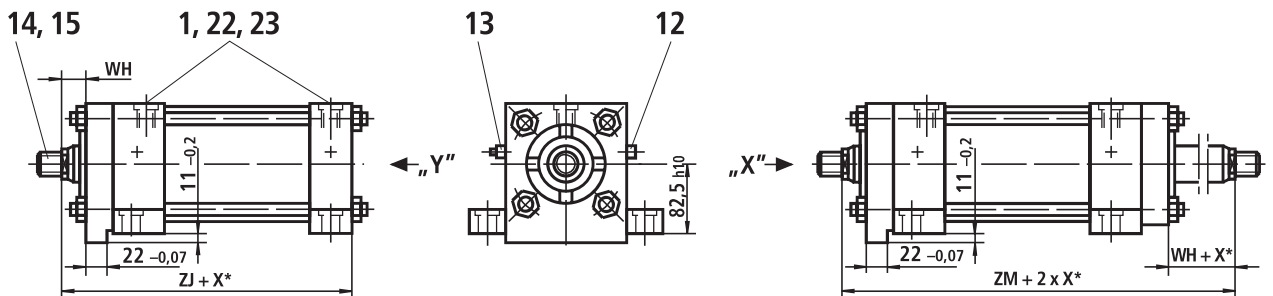

Stroke_{min} = 70 mm with thread version "E"
(only for double-rod cylinder)

Type of mounting M Operating pressure 210 bar

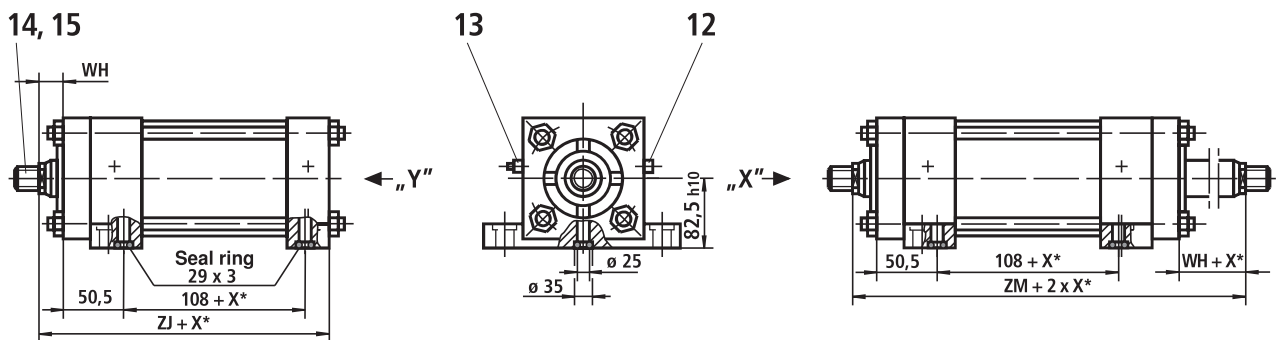

Stroke_{min} = 70 mm with thread version "E"
(only for double-rod cylinder)

Piston rod Ø	ØRD f7	VD	WH	XG	XJ	XV ¹⁾ min.	XV ¹⁾ max.	ZJ	ZM	B3	SW1	Cushioning lengths	
												kolben seitig	on piston rod side
50	66.6	6	28.5	76	187	127.5	139 + X*	209.5	266	14	46	33	35
56	70	7	28.5	76	187	127.5	139 + X*	209.5	266	14	46		
63	79.3	10	35	82.5	193.5	134	145.5 + X*	216	279	15	55		
90	108	10	35	82.5	193.5	134	145.5 + X*	216	279	15	75		

X* = stroke length

¹⁾ Always specify dimension "XV" in clear text on the order (observe XV_{min} and XV_{max})

Piston Ø 125 (dimensions in mm)

For explanations of items, see page 7

Type of mounting N Operating pressure 210 bar

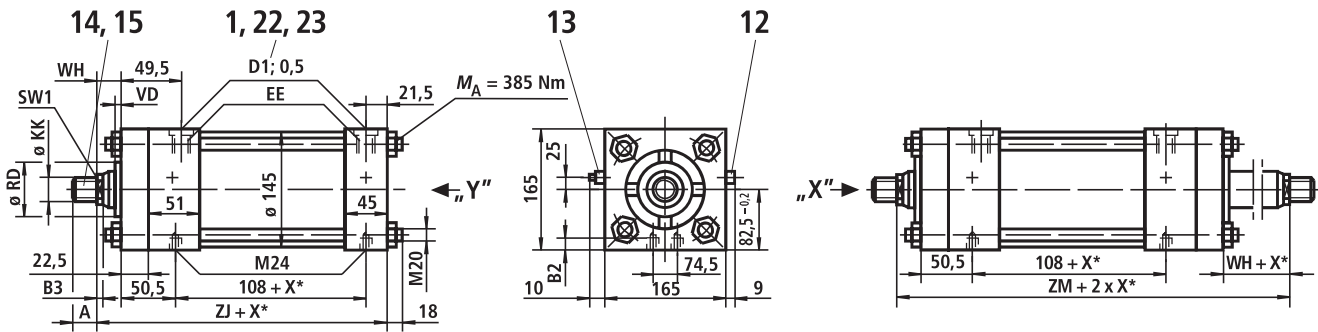

Stroke_{min} = 70 mm with thread version "E"
(only for double-rod cylinder)

Type of mounting T Operating pressure 210 bar

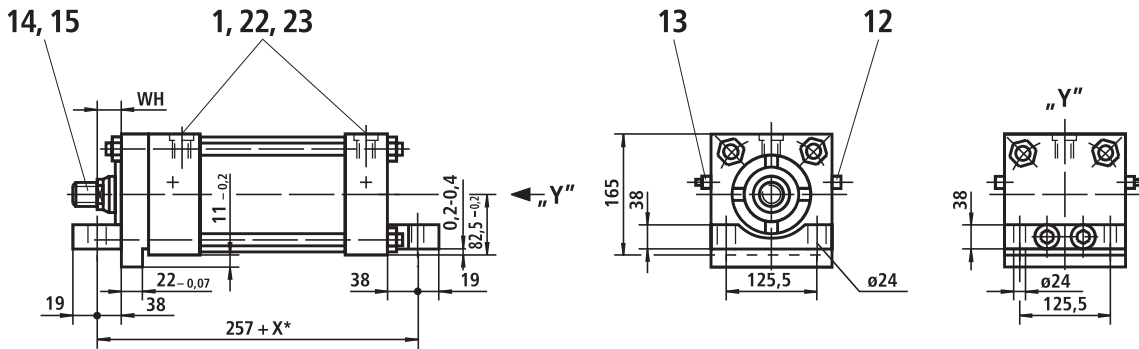

Type of mounting P Operating pressure 210 bar

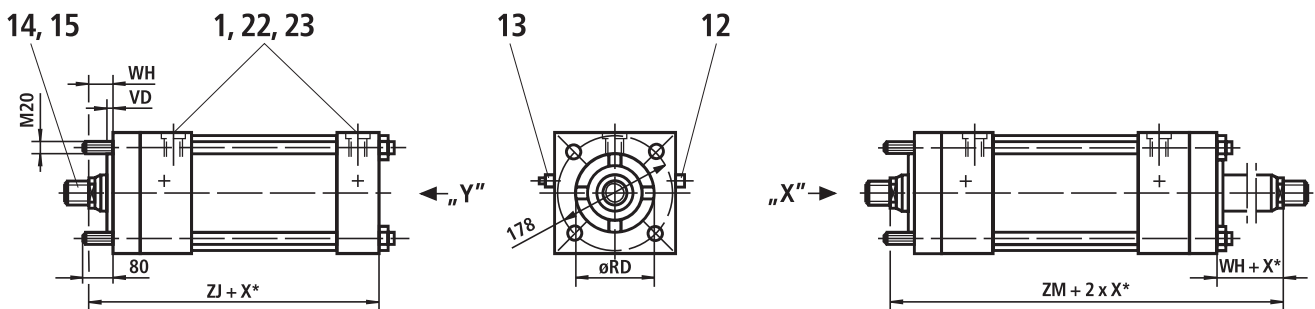

Stroke_{min} = 70 mm with thread version "E"
(only for double-rod cylinder)

Piston rod Ø	KK			A		EE				D1			
	Thread version			Thread version		Pipe connection				Pipe connection			
	C, E	B	F	C, E, B	F	01	13	02	14	01	13	02	14
50	M39 x 2	M45 x 2	M45 x 3	57	100	G3/4	G1	M27 x 2	M33 x 2	42	47	42	47
56	M39 x 2	M45 x 2	M45 x 3	57	100								
63	M48 x 2	M56 x 2	M52 x 3	76	115								
90	M64 x 2	M76 x 2	M52 x 3	89	115								

X* = stroke length

Piston Ø 125 (dimensions in mm)

For explanations of items, see page 7

Type of mounting **Q** Operating pressure 210 bar

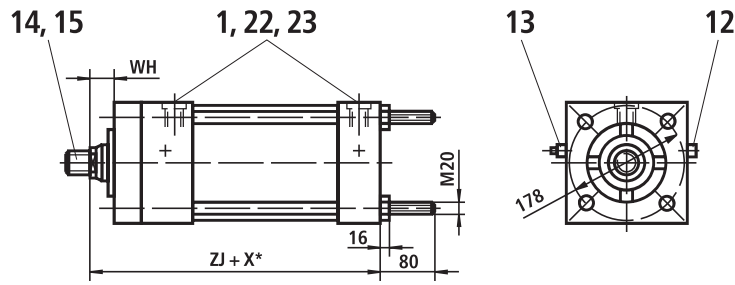

Additional thread versions

Thread version "E"

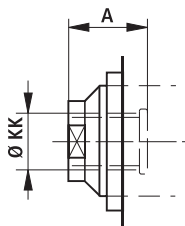

Thread version "F"

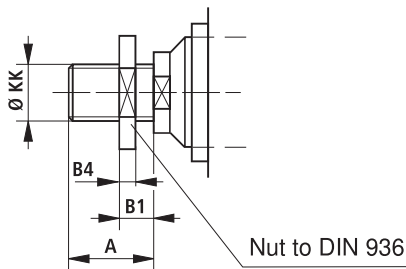

Self-aligning clevis CGK 50

suitable for thread version "F"
 Material no.: **R900001334**
 Weight: 3.5 kg
 Permissible load: 145 kN

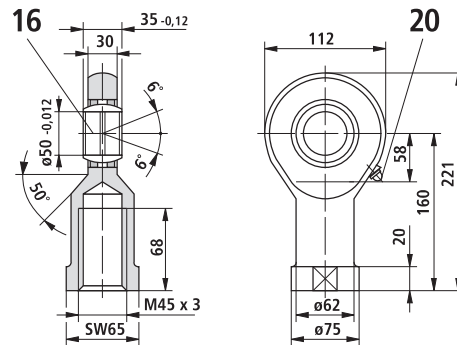

Self-aligning clevis CGK 60

suitable for thread version "F"
 Material no.: **R900001335**
 Weight: 5.6 kg
 Permissible load: 225 kN

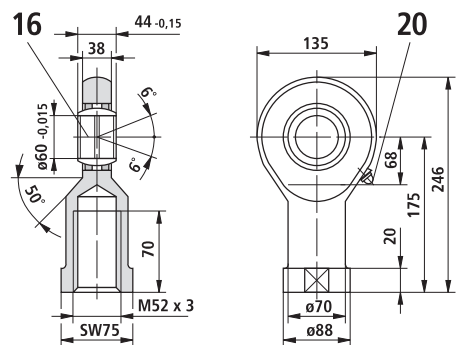

Piston rod Ø	ØRD f7	B4	VD	WH	ZJ	ZM	B1	B2	B3	SW1	Cushioning lengths	
											piston side	piston rod side
50	66.6	18	6	28.5	209.5	266	32	40	14	46	33	35
56	70	18	7	28.5	209.5	266	32	40	14	46		
63	79.3	20	10	35	216	279	45	25	15	55		
90	108	20	10	35	216	279	45	25	15	75		

X* = stroke length

Piston Ø 150 (dimensions in mm)

For explanations of items, see page 7

Type of mounting B Operating pressure 210 bar

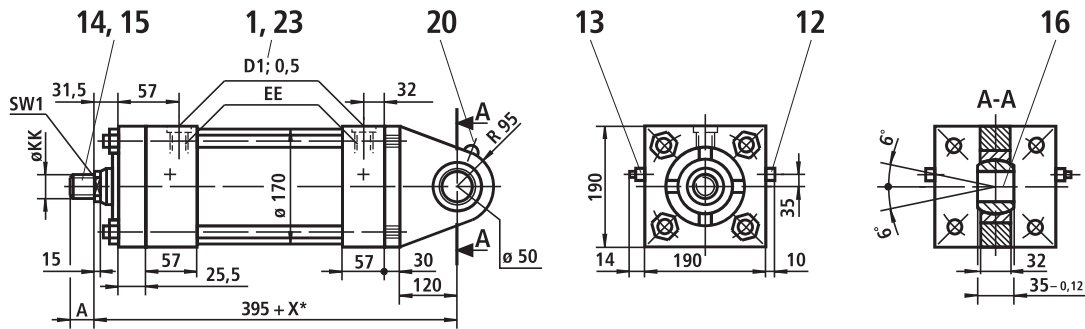

Type of mounting G Operating pressure 210 bar

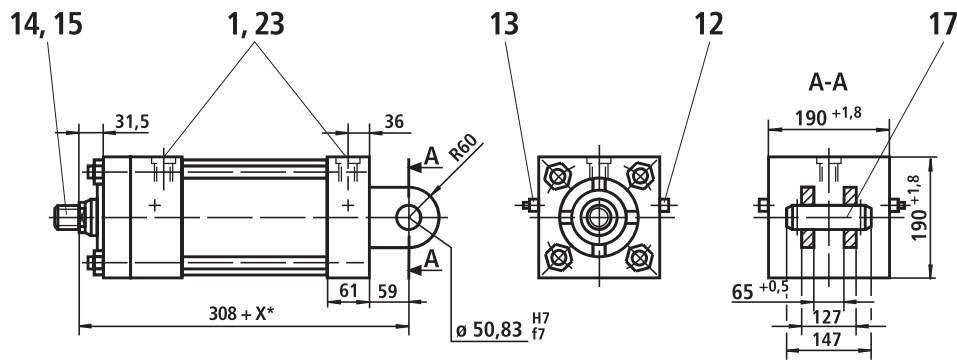

Type of mounting C Operating pressure with piston rod Ø 63 and Ø 70: 130 bar on cap side, 210 bar on piston rod side
Operating pressure with piston rod Ø 80 and Ø 100: 60 bar on cap side, 210 bar on piston rod side

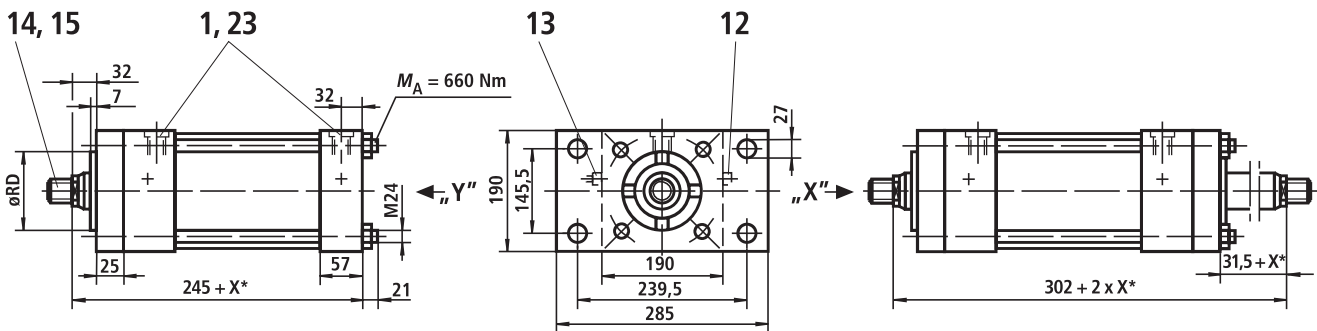

Stroke_{min} = 85 mm with thread version "E"
(only for double-rod cylinder)

Piston rod Ø	KK			A		EE				D1			
	Thread version			Thread version		Pipe connection				Pipe connection			
	C, E	B	F	C, E, B	F	01	13	02	14	01	13	02	14
63	M48 x 2	M56 x 2	M52 x 3	76	115								
70	M48 x 2	M56 x 2	M52 x 3	76	115								
80	M58 x 2	M68 x 2	M64 x 4	89	145	G1	G1 1/4	M33 x 2	M42 x 2	47	58	47	58
100	M76 x 2	M95 x 2	M64 x 4	101	145								

X* = stroke length

Piston Ø 150 (dimensions in mm)

For explanations of items, see page 7

Type of mounting H Operating pressure 210 bar

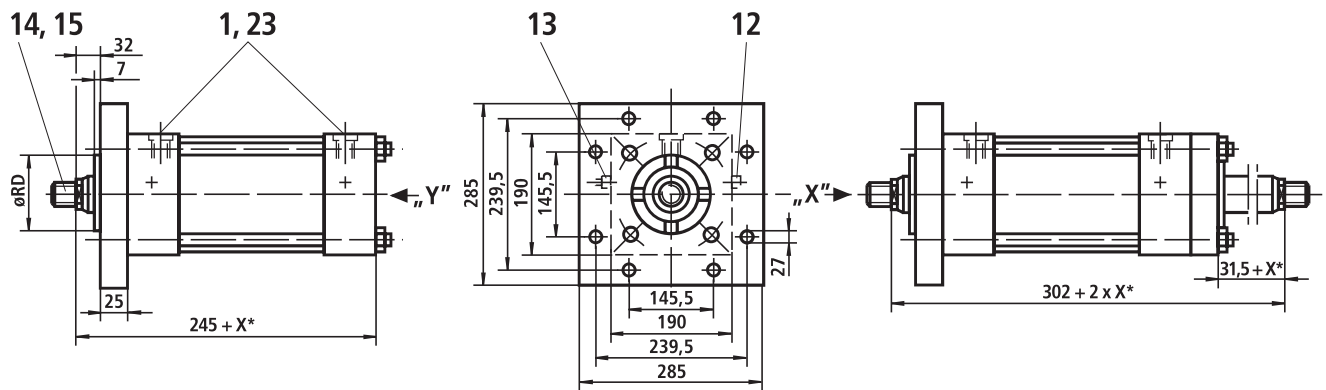

Stroke_{min} = 85 mm with thread version "E"
(only for double-rod cylinder)

Type of mounting D Operating pressure with piston rod Ø 63 and Ø 70: 210 bar on cap side, 150 bar on piston rod side
Operating pressure with piston rod Ø 80 and Ø 100: 210 bar on cap side, 210 bar on piston rod side

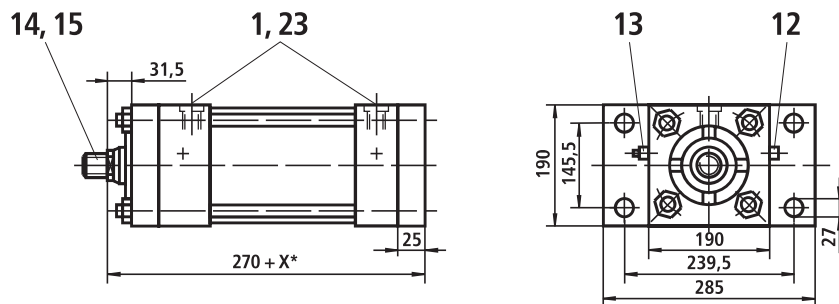

Type of mounting K Operating pressure 210 bar

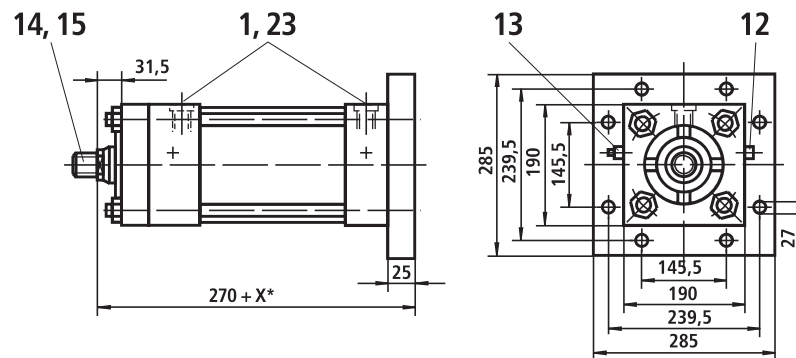

Piston rod Ø	ØRD f7								SW1	Cushioning lengths	
										piston side	piston rod side
63	79.3								55	38	35
70	90							60			
80	95.2							75			
100	120								85		

X* = stroke length

Piston Ø 150 (dimensions in mm)

For explanations of items, see page 7

Type of mounting R Operating pressure 210 bar

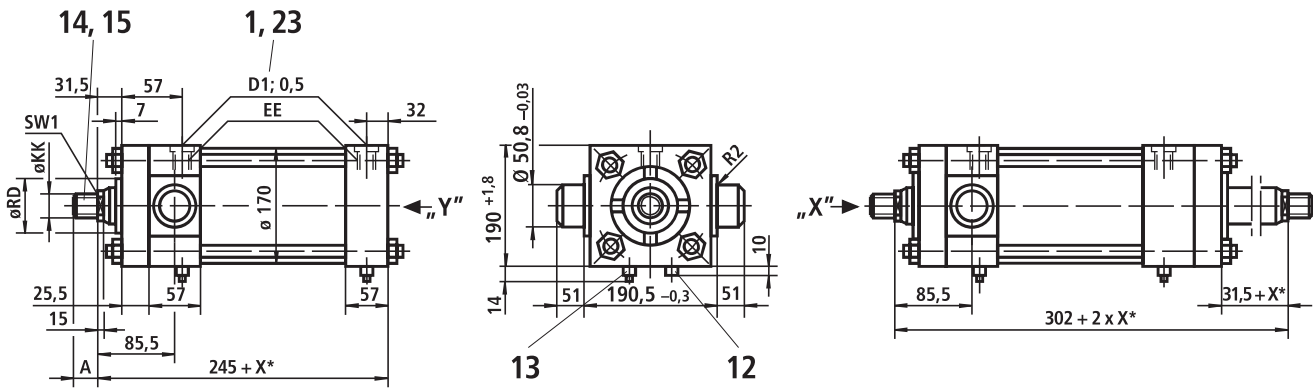

Stroke_{min} = 85 mm with thread version "E"
(only for double-rod cylinder)

Type of mounting E Operating pressure 210 bar

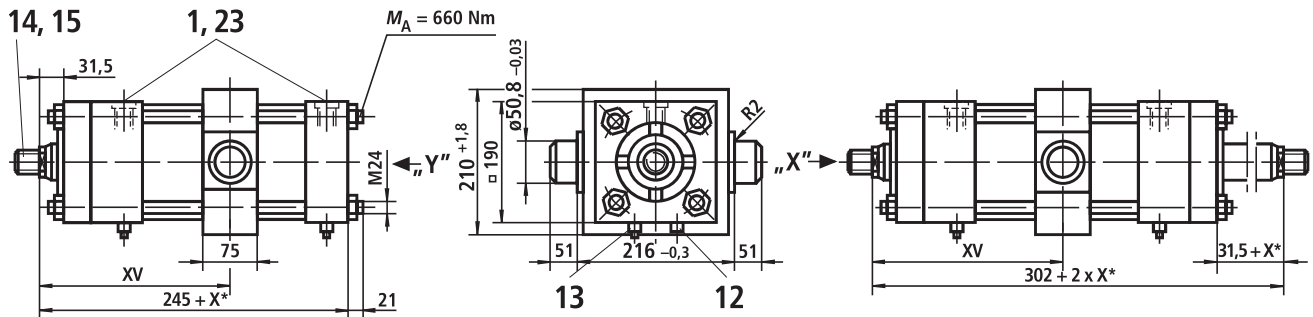

Stroke_{min} = 20 mm
Always specify dimension "XV"
in clear text on the order
(observe XV_{min} and XV_{max})

Note:
Dimensions for cylinder with piston rod
extension "LY" in the retracted
condition, see index 2 on page 5.

Stroke_{min} = 85 mm
with thread version "E"
(only for double-rod cylinder)

Type of mounting S Operating pressure 210 bar

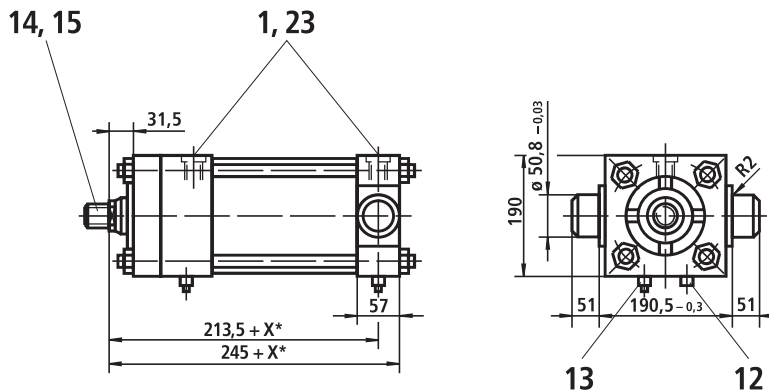

Piston rod Ø	KK			A		EE				D1			
	Thread version			Thread version		Pipe connection				Pipe connection			
	C, E	B	F	C, E, B	F	01	13	02	14	01	13	02	14
63	M48 x 2	M56 x 2	M52 x 3	76	115								
70	M48 x 2	M56 x 2	M52 x 3	76	115								
80	M58 x 2	M68 x 2	M64 x 4	89	145	G1	G1 1/4	M33 x 2	M42 x 2	47	58	47	58
100	M76 x 2	M95 x 2	M64 x 4	101	145								

X* = stroke length

Piston Ø 150 (dimensions in mm)

For explanations of items, see page 7

Type of mounting F Operating pressure 210 bar

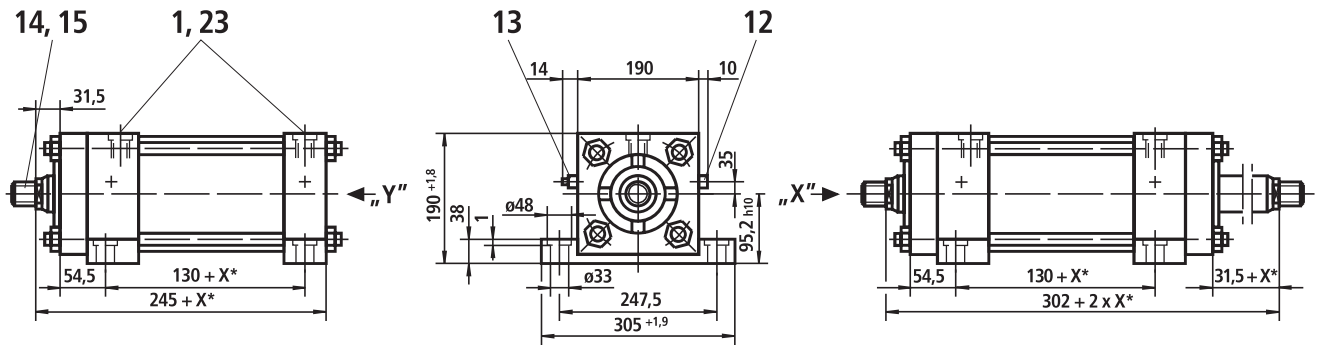

Stroke_{min} = 85 mm with thread version "E"
(only for double-rod cylinder)

Type of mounting L Operating pressure 210 bar

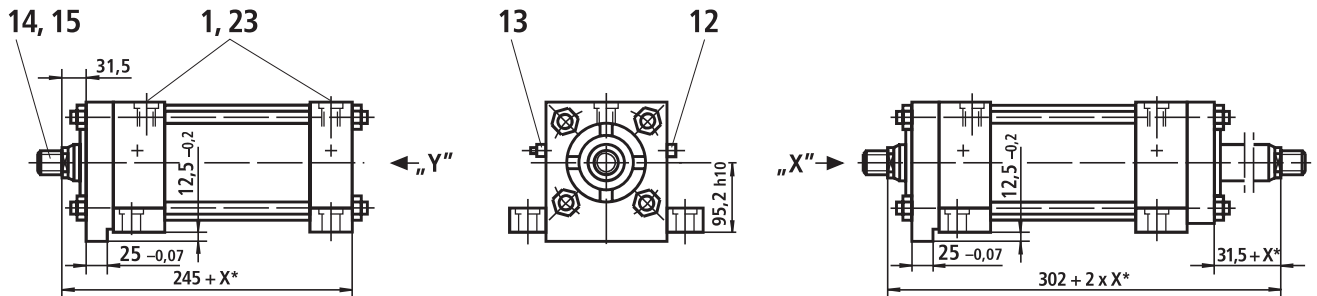

Stroke_{min} = 85 mm with thread version "E"
(only for double-rod cylinder)

Type of mounting M Operating pressure 210 bar

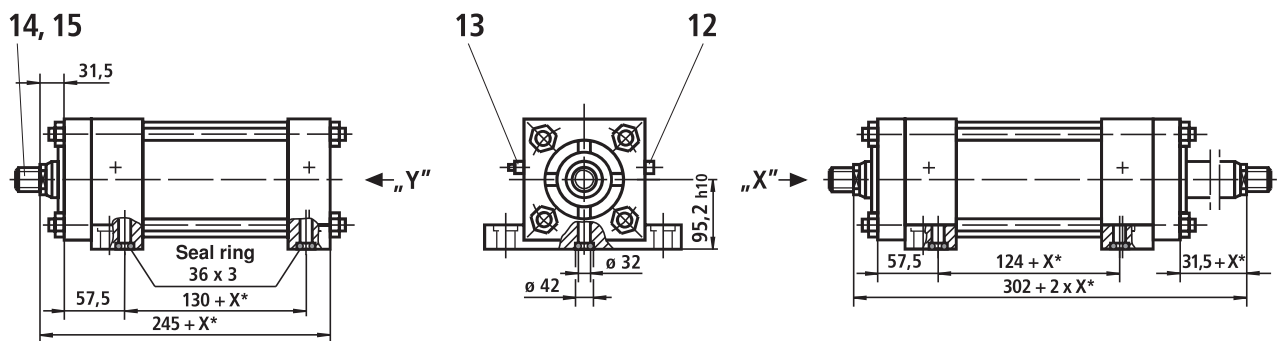

Stroke_{min} = 85 mm with thread version "E"
(only for double-rod cylinder)

Piston rod Ø	ØRD f7	XV ¹⁾ min.	XV ¹⁾ max.					SW1	Cushioning lengths	
									piston side	piston rod side
63	79.3	151.5	150.5 + X*					55	38	35
70	90	151.5	150.5 + X*				60			
80	95.2	151.5	150.5 + X*				75			
100	120	151.5	150.5 + X*				85			

X* = stroke length

¹⁾ Always specify dimension "XV" in clear text on the order (observe XV_{min} and XV_{max})

Piston Ø 150 (dimensions in mm)

For explanations of items, see page 7

Type of mounting N Operating pressure 210 bar

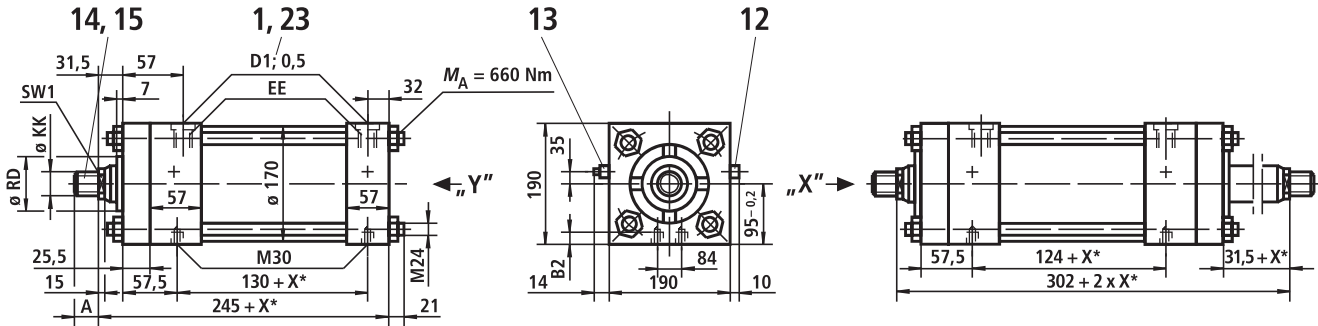

Stroke_{min} = 85 mm with thread version "E"
(only for double-rod cylinder)

Type of mounting T Operating pressure 210 bar

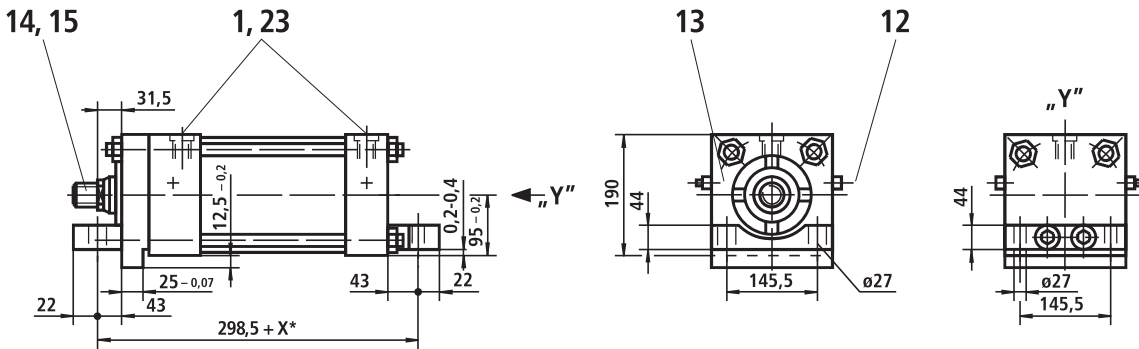

Type of mounting P Operating pressure 210 bar

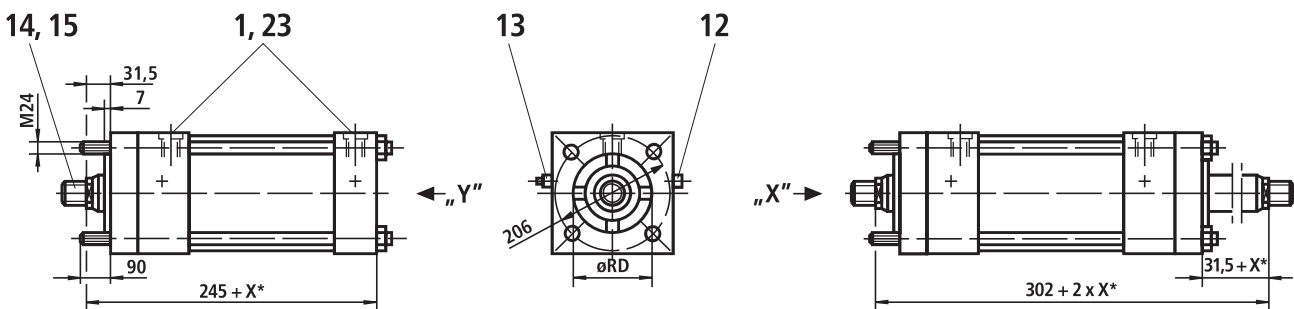

Stroke_{min} = 85 mm with thread version "E"
(only for double-rod cylinder)

Piston rod Ø	KK			A		EE				D1			
	Thread version			Thread version		Pipe connection				Pipe connection			
	C, E	B	F	C, E, B	F	01	13	02	14	01	13	02	14
63	M48 x 2	M56 x 2	M52 x 3	76	115								
70	M48 x 2	M56 x 2	M52 x 3	76	115								
80	M58 x 2	M68 x 2	M64 x 4	89	145	G1	G1 1/4	M33 x 2	M42 x 2	47	58	47	58
100	M76 x 2	M95 x 2	M64 x 4	101	145								

X* = stroke length

Piston Ø 150 (dimensions in mm)

For explanations of items, see page 7

Type of mounting **Q** Operating pressure 210 bar

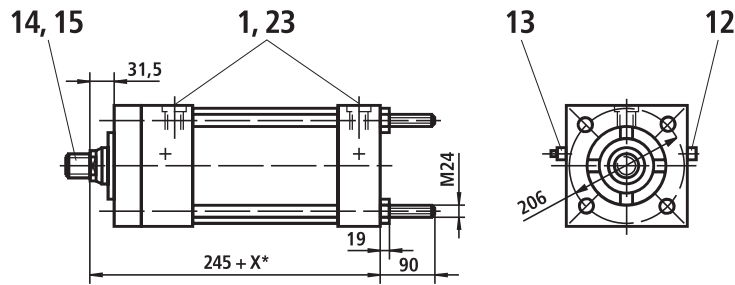

Additional thread versions

Thread version "E"

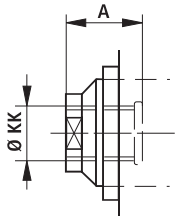

Thread version "F"

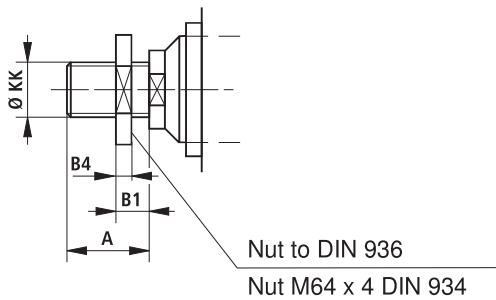

Self-aligning clevis CGK 60

suitable for thread version "F"
 Material no.: **R900001335**
 Weight: 5.6 kg
 Permissible load: 225 kN

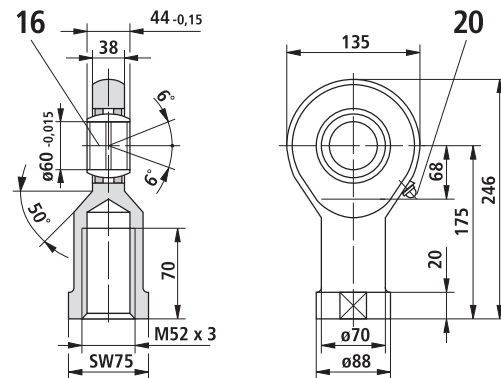

Self-aligning clevis CGK 80

suitable for thread version "F"
 Material no.: **R900001928**
 Weight: 13.1 kg
 Permissible load: 371 kN

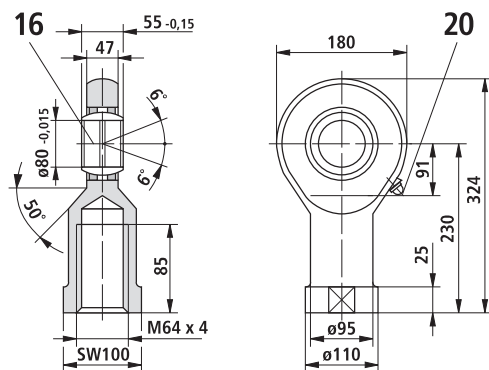

Piston rod Ø	ØRD f7	B4				B1	B2	SW1	Cushioning lengths	
									piston side	piston rod side
63	79.3	20				45	45	55	38	35
70	90	20				45	45	60		
80	95.2	51				60	30	75		
100	120	51				60	30	85		

X* = stroke length

Piston Ø 180 (dimensions in mm)

For explanations of items, see page 7

Type of mounting B Operating pressure 210 bar

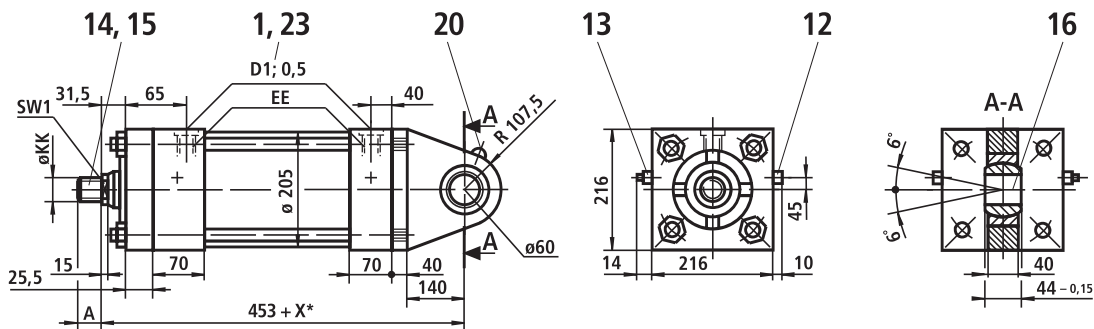

Type of mounting G Operating pressure 210 bar

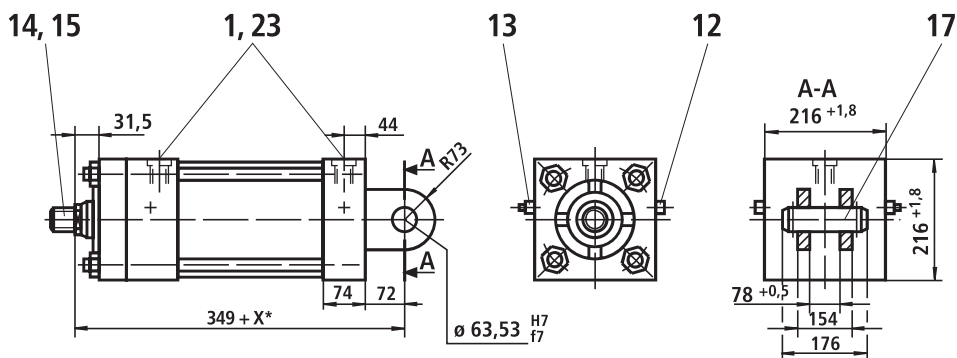

Type of mounting C Operating pressure with piston rod Ø 80 and Ø 90: 110 bar on cap side, 210 bar on piston rod side
 Operating pressure with piston rod Ø 125: 60 bar on cap side, 210 bar on piston rod side

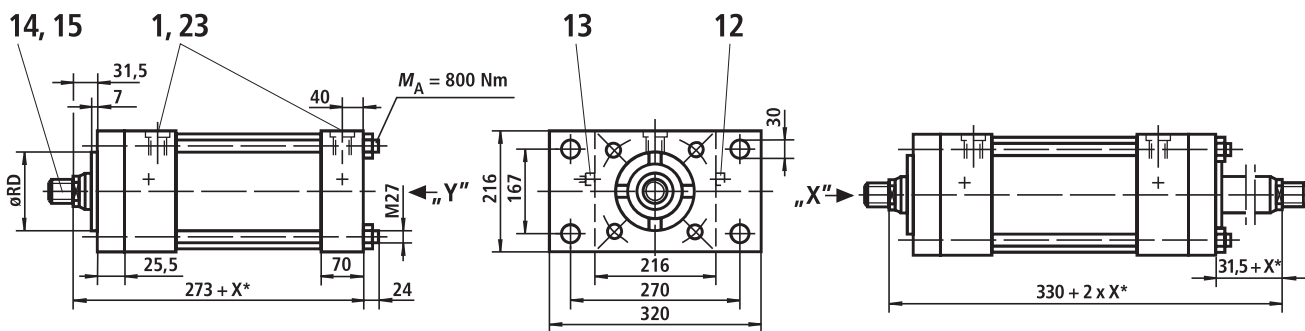

Stroke_{min} = 105 mm with thread version "E"
 (only for double-rod cylinder)

Piston rod Ø	KK			A		EE				D1			
	Thread version			Thread version		Pipe connection				Pipe connection			
	C, E	B	F	C, E, B	F	01	13	02	14	01	13	02	14
80	M58 x 2	M68 x 2	M64 x 4	89	145								
90	M64 x 2	M76 x 2	M80 x 2	89	80								
125	M90 x 2	M110 x 2	M100 x 2	127	100	G1 1/4	G1 1/2	M242 x 2	M48 x 2	58	65	58	65

X* = stroke length

Piston Ø 180 (dimensions in mm)

For explanations of items, see page 7

Type of mounting H Operating pressure 210 bar

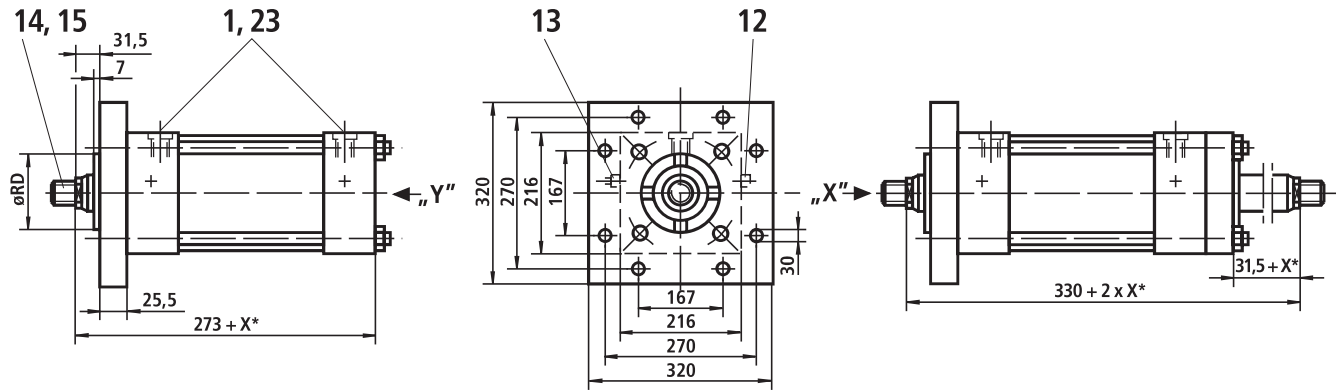

Stroke_{min} = 105 mm with thread version "E"
(only for double-rod cylinder)

Type of mounting D Operating pressure with piston rod Ø 80 and Ø 90: 210 bar on cap side, 110 bar on piston rod side
Operating pressure with piston rod Ø 125: 210 bar on cap side, 150 bar on piston rod side

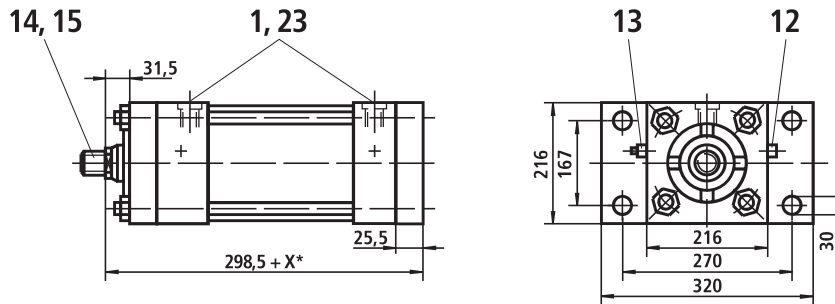

Type of mounting K Operating pressure 210 bar

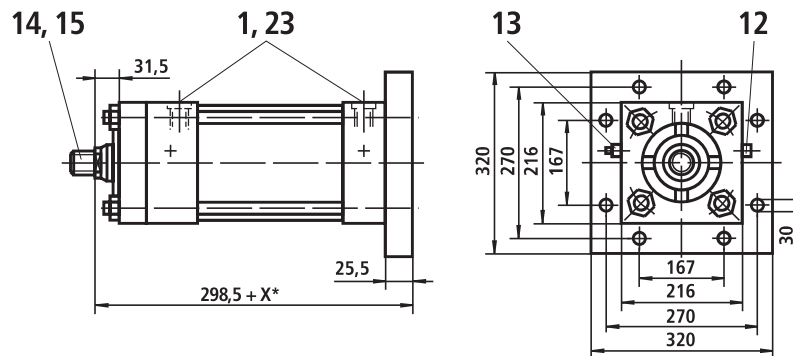

Piston rod Ø	ØRD f7								SW1	Cushioning lengths	
										piston side	piston rod side
80	95.2								75	50	50
90	108							75			
125	146							115			

X* = stroke length

Piston Ø 180 (dimensions in mm)

For explanations of items, see page 7

Type of mounting R Operating pressure 210 bar

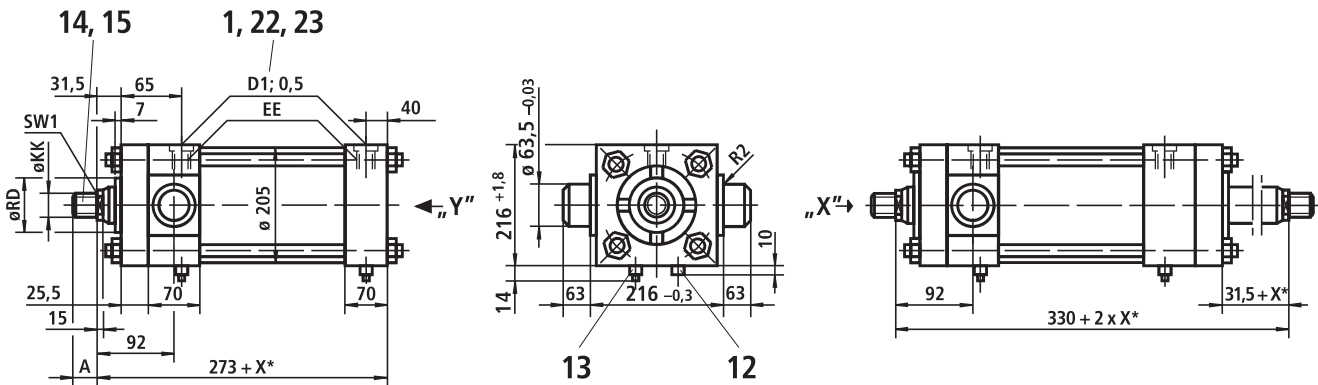

Stroke_{min} = 105 mm with thread version "E"
(only for double-rod cylinder)

Type of mounting E Operating pressure 210 bar

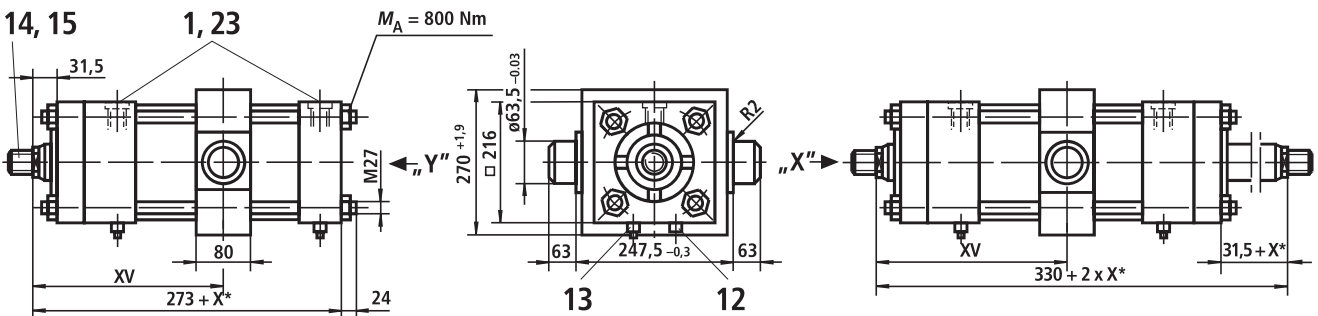

Stroke_{min} = 25 mm
Always specify dimension "XV"
in clear text on the order
(observe XV_{min} and XV_{max})

Note:
Dimensions for cylinder with piston rod
extension "LY" in the retracted
condition, see index 2 on page 5.

Stroke_{min} = 105 mm
with thread version "E"
(only for double-rod cylinder)

Type of mounting S Operating pressure 210 bar

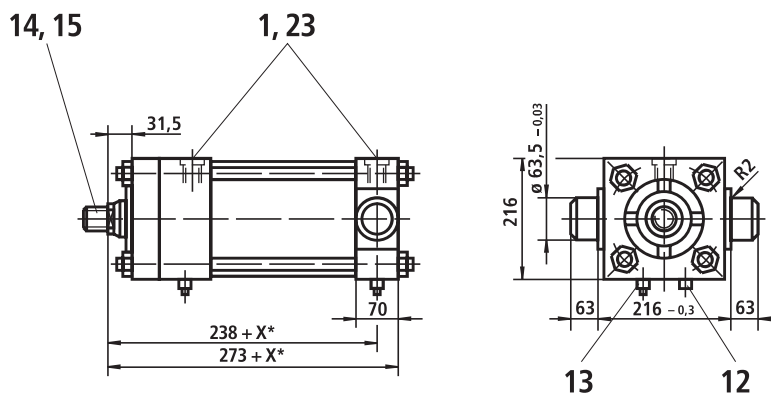

Piston rod Ø	KK			A		EE				D1			
	Thread version			Thread version		Pipe connection				Pipe connection			
	C, E	B	F	C, E, B	F	01	13	02	14	01	13	02	14
80	M58 x 2	M68 x 2	M64 x 4	89	145								
90	M64 x 2	M76 x 2	M80 x 2	89	80								
125	M90 x 2	M110 x 2	M100 x 2	127	100	G1 1/4	G1 1/2	M242 x 2	M48 x 2	58	65	58	65

X* = stroke length

Piston Ø 180 (dimensions in mm)

For explanations of items, see page 7

Type of mounting F Operating pressure 210 bar

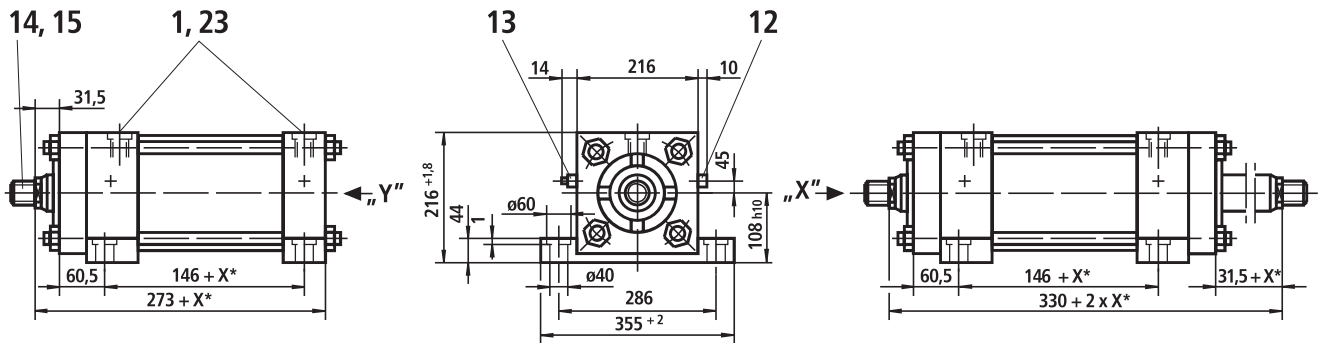

Stroke_{min} = 105 mm with thread version "E"
(only for double-rod cylinder)

Type of mounting L Operating pressure 210 bar

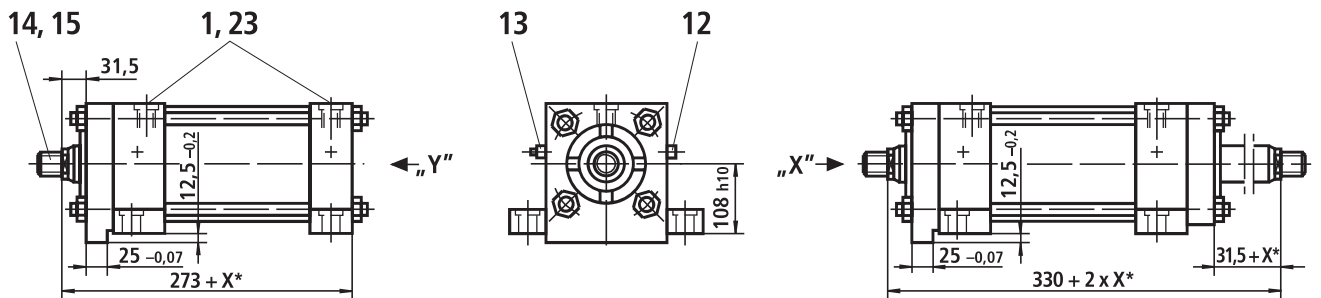

Stroke_{min} = 105 mm with thread version "E"
(only for double-rod cylinder)

Type of mounting M Operating pressure 210 bar

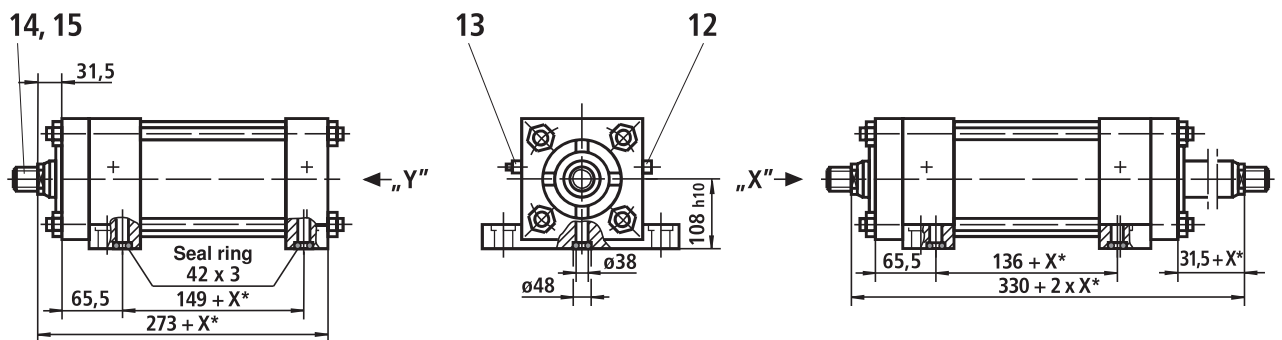

Stroke_{min} = 105 mm with thread version "E"
(only for double-rod cylinder)

Piston rod Ø	ØRD f7	XV ¹⁾ min.	XV ¹⁾ max.						SW1	Cushioning lengths	
										piston side	piston rod side
80	95.2	167	163 + X*						75	50	50
90	108	167	163 + X*					75			
125	146	167	163 + X*					115			

X* = stroke length

¹⁾ Always specify dimension "XV" in clear text on the order (observe XV_{min} and XV_{max})

Piston Ø 180 (dimensions in mm)

For explanations of items, see page 7

Type of mounting N Operating pressure 210 bar

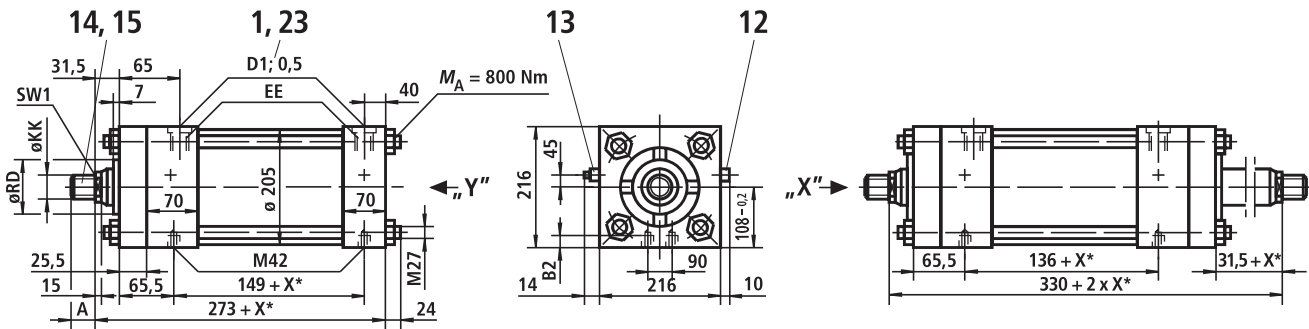

Stroke_{min} = 105 mm with thread version "E"
(only for double-rod cylinder)

Type of mounting T Operating pressure 210 bar

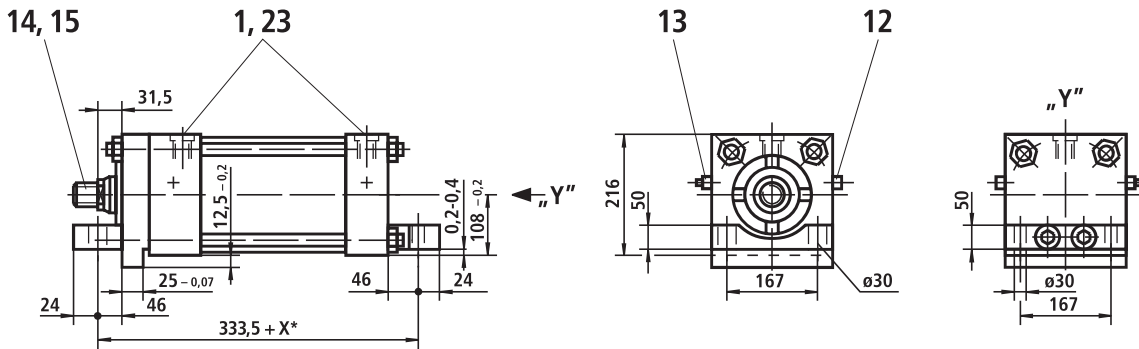

Type of mounting P Operating pressure 210 bar

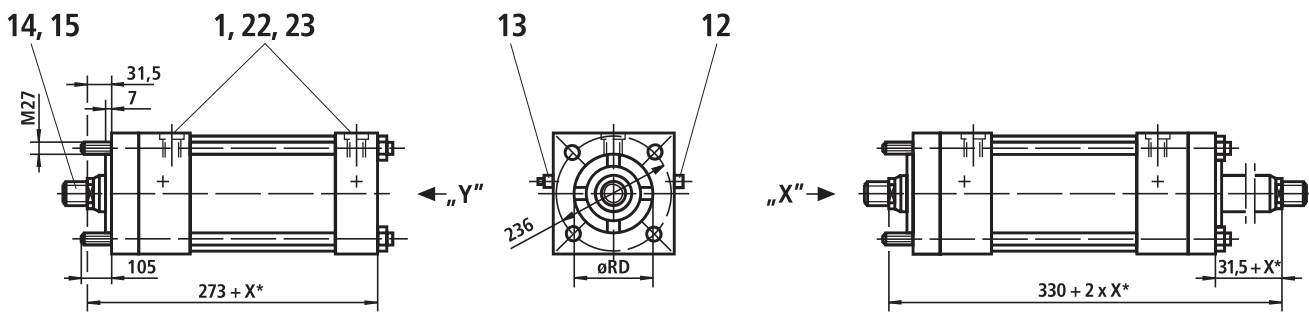

Stroke_{min} = 105 mm with thread version "E"
(only for double-rod cylinder)

Piston rod Ø	KK			A		EE				D1			
	Thread version			Thread version		Pipe connection				Pipe connection			
	C, E	B	F	C, E, B	F	01	13	02	14	01	13	02	14
80	M58 x 2	M68 x 2	M64 x 4	89	145								
90	M64 x 2	M76 x 2	M80 x 2	89	80								
125	M90 x 2	M110 x 2	M100 x 2	127	100	G1 1/4	G1 1/2	M242 x 2	M48 x 2	58	65	58	65

X* = stroke length

Piston Ø 180 (dimensions in mm)

For explanations of items, see page 7

Type of mounting **Q** Operating pressure 210 bar

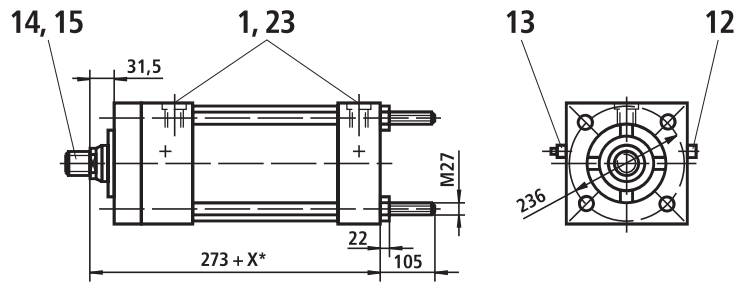

Additional thread versions

Thread version "E"

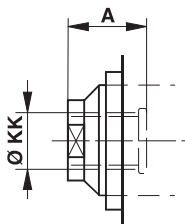

Thread version "F"

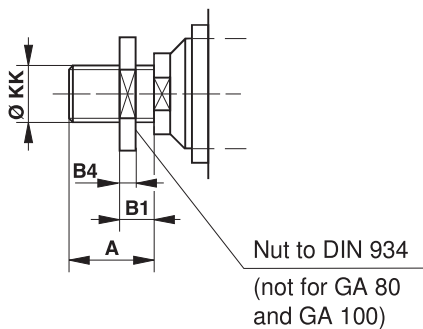

Self-aligning clevis CGK 80

suitable for thread version "F"
Material no.: **R900001928**
Weight: 13.1 kg
Permissible load: 375 kN

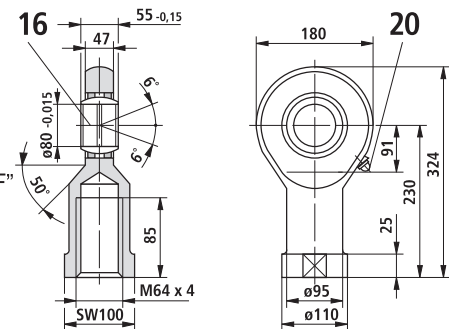

Self-aligning clevis CGA 80

suitable for thread version "F"
Material no.: **R900303132**
Weight: 12.2 kg
Permissible load: 385 kN

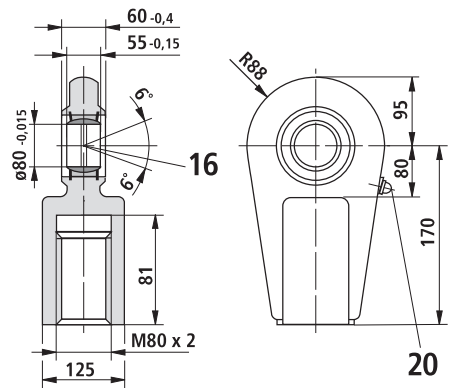

Self-aligning clevis CGA 100

suitable for thread version "F"
Material no.: **R900303133**
Weight: 21.5 kg
Permissible load: 535 kN

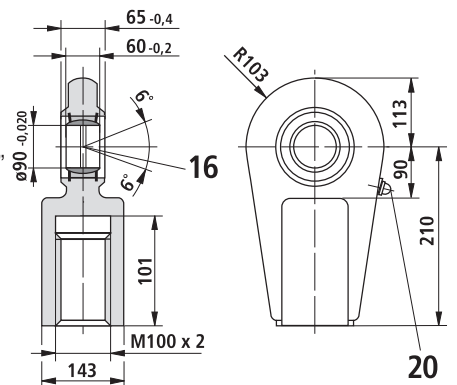

Piston rod Ø	ØRD f7	B4					B1	B2	SW1	Cushioning lengths	
										piston side	piston rod side
80	95.2	51					60	40	75	50	50
90	108	-					-	40	75		
125	146	-					-	28	115		

X* = stroke length

Piston Ø 200 (dimensions in mm)

For explanations of items, see page 7

Type of mounting B Operating pressure 210 bar

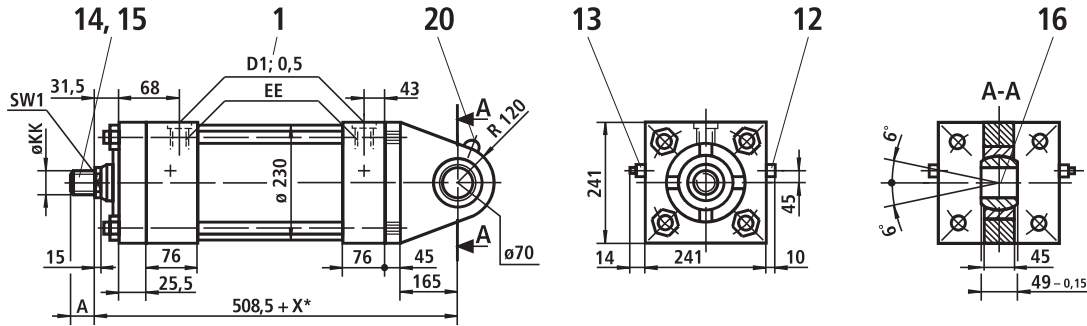

Type of mounting G Operating pressure 210 bar

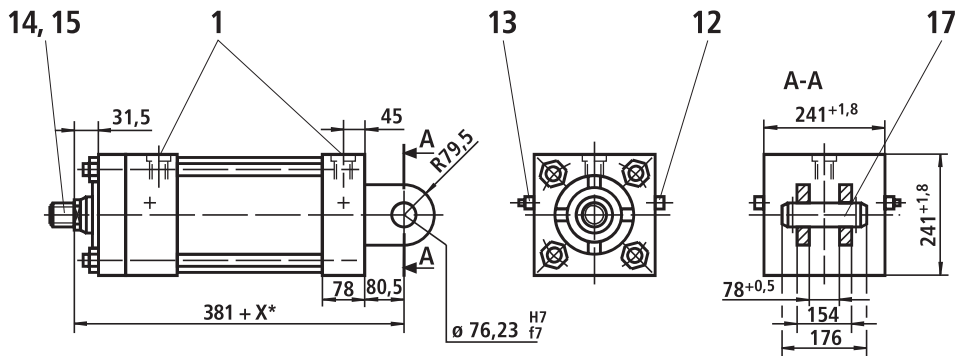

Type of mounting C Operating pressure with piston rod Ø 90 and Ø 100: 70 bar on cap side, 210 bar on piston rod side
 Operating pressure with piston rod Ø 140: 40 bar on cap side, 210 bar on piston rod side

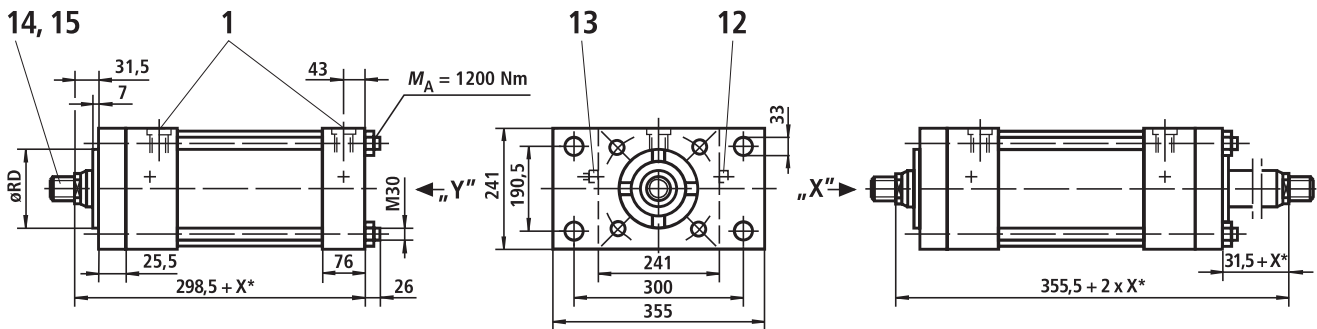

Stroke_{min} = 120 mm with thread version "E"
 (only for double-rod cylinder)

Piston rod Ø	KK			A		EE				D1			
	Thread version			Thread version		Pipe connection				Pipe connection			
	C, E	B	F	C, E, B	F	01	13	02	14	01	13	02	14
90	M64 x 2	M76 x 2	M80 x 2	89	80	G1 1/2	-	M48 x 2	-	65	-	65	-
100	M76 x 2	M95 x 2	M80 x 2	101	80		-	-	-	-	-	-	-
140	M100 x 2	M130 x 2	M110 x 2	140	110		-	-	-	-	-	-	-

X* = stroke length

Piston Ø 200 (dimensions in mm)

For explanations of items, see page 7

Type of mounting H Operating pressure 210 bar

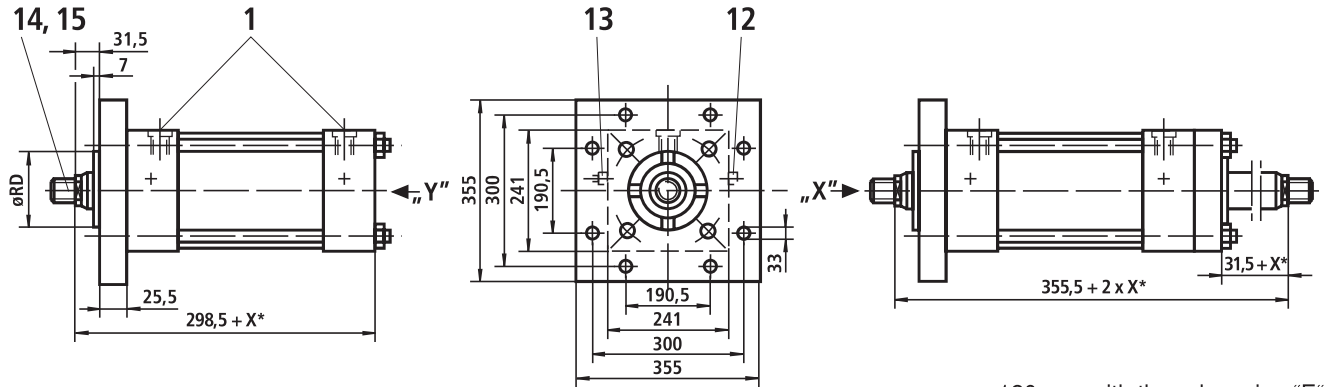

Stroke_{min} = 120 mm with thread version "E"
(only for double-rod cylinder)

Type of mounting D Operating pressure with piston rod Ø 90 and Ø 100: 210 bar on cap side, 110 bar on piston rod side
Operating pressure with piston rod Ø 140: 210 bar on cap side, 150 bar on piston rod side

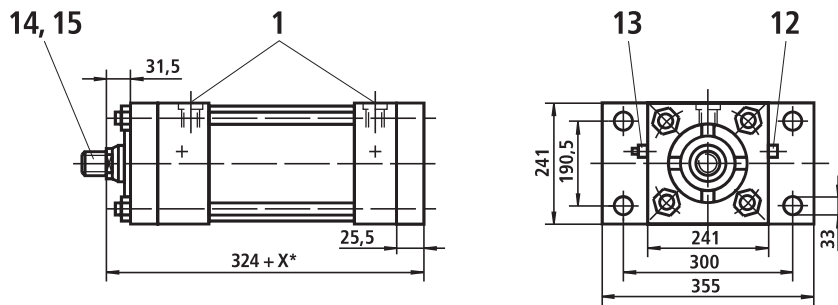

Type of mounting K Operating pressure 210 bar

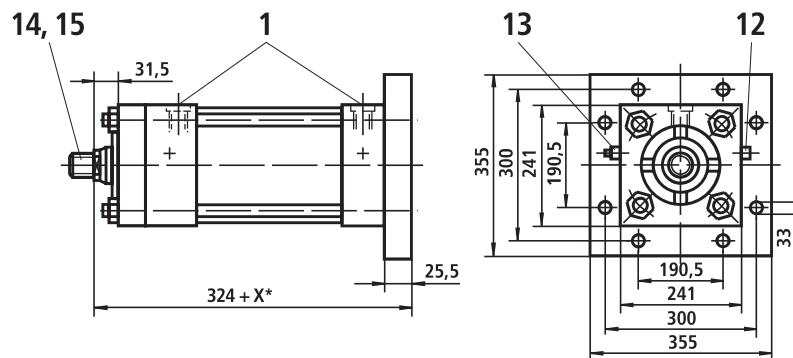

Piston rod Ø	ØRD f7								SW1	Cushioning lengths	
										piston side	piston rod side
90	108								75	50	50
100	120							85			
140	158							120			

X* = stroke length

Piston Ø 200 (dimensions in mm)

For explanations of items, see page 7

Type of mounting R Operating pressure 210 bar

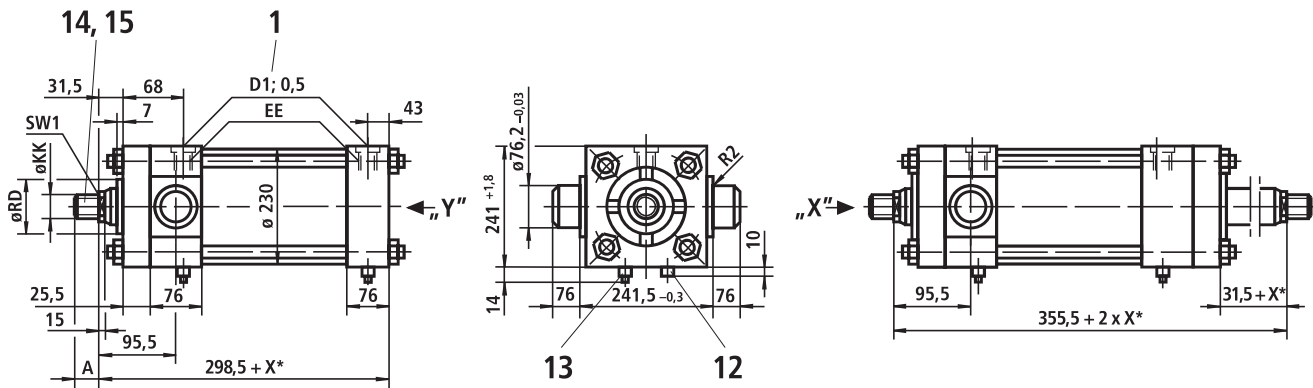

Stroke_{min} = 120 mm with thread version "E"
(only for double-rod cylinder)

Type of mounting E Operating pressure 210 bar

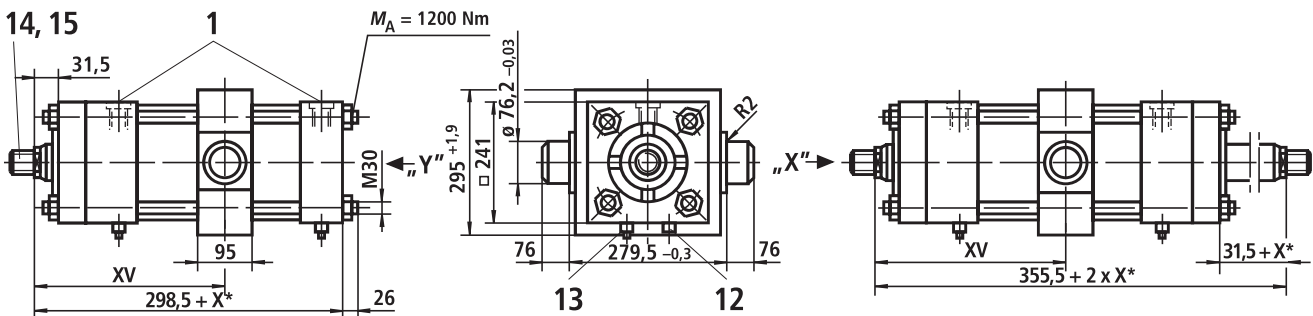

Stroke_{min} = 25 mm
Always specify dimension "XV"
in clear text on the order
(observe XV_{min} and XV_{max})

Note:
Dimensions for cylinder with piston rod
extension "LY" in the retracted
condition, see index 2 on page 5.

Stroke_{min} = 120 mm
with thread version "E"
(only for double-rod cylinder)

Type of mounting S Operating pressure 210 bar

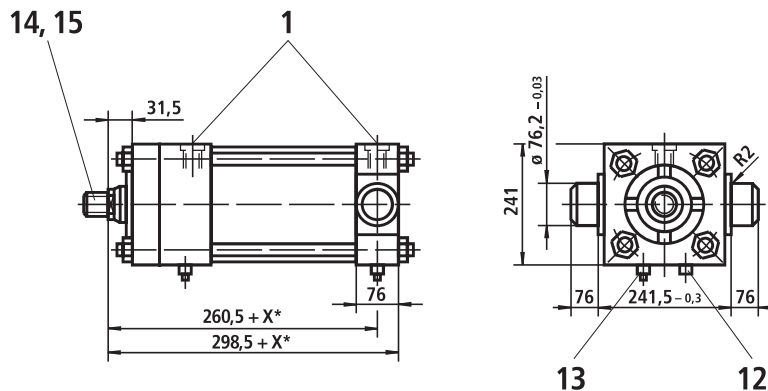

Piston rod Ø	KK			A		EE				D1			
	Thread version			Thread version		Pipe connection				Pipe connection			
	C, E	B	F	C, E, B	F	01	13	02	14	01	13	02	14
90	M64 x 2	M76 x 2	M80 x 2	89	80	G1 1/2	-	M48 x 2	-	65	-	65	-
100	M76 x 2	M95 x 2	M80 x 2	101	80		-	-	-	-	-	-	-
140	M100 x 2	M130 x 2	M110 x 2	140	110		-	-	-	-	-	-	-

X* = stroke length

Piston Ø 200 (dimensions in mm)

For explanations of items, see page 7

Type of mounting F Operating pressure 210 bar

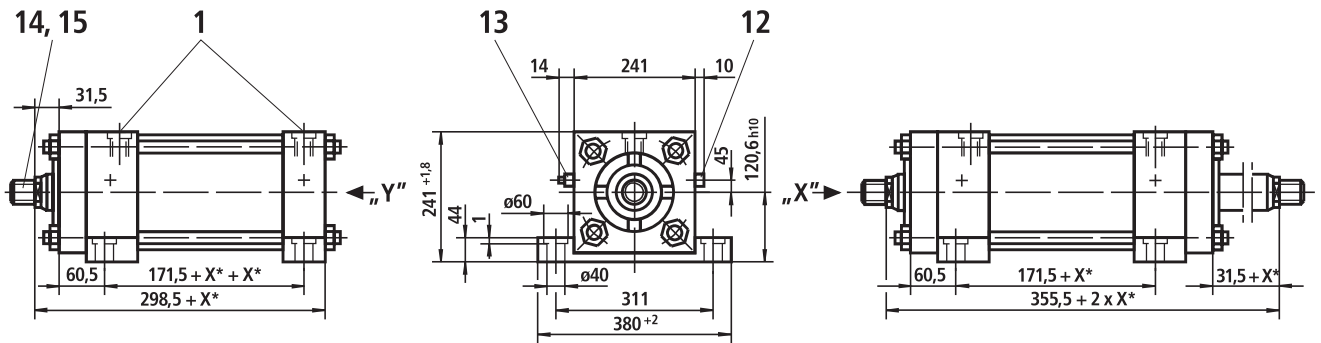

Stroke_{min} = 120 mm with thread version "E"
(only for double-rod cylinder)

Type of mounting L Operating pressure 210 bar

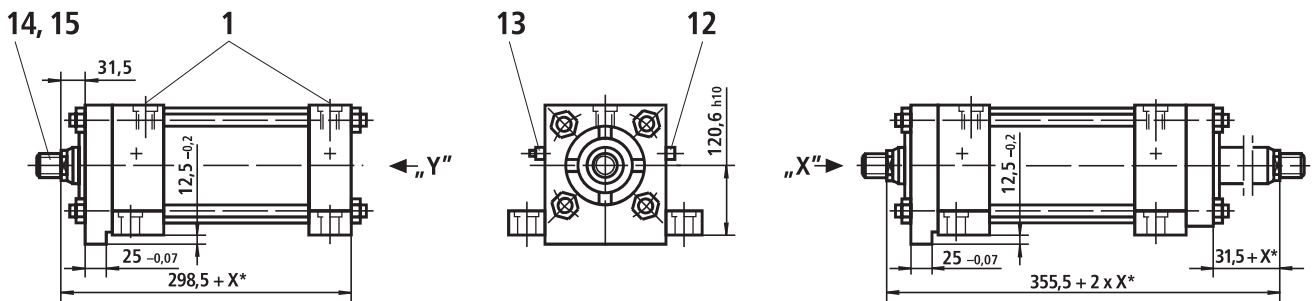

Stroke_{min} = 120 mm with thread version "E"
(only for double-rod cylinder)

Type of mounting M Operating pressure 210 bar

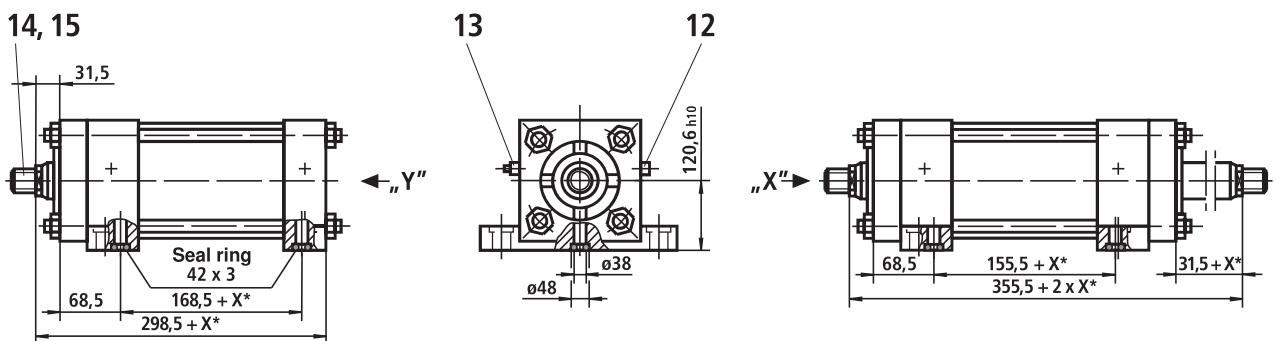

Stroke_{min} = 120 mm with thread version "E"
(only for double-rod cylinder)

Piston rod Ø	ØRD f7	XV ¹⁾ min.	XV ¹⁾ max.						SW1	Cushioning lengths	
										piston side	piston rod side
90	108	180.5	175 + X*						75	50	50
100	120	180.5	175 + X*					85			
140	158	180.5	175 + X*					120			

X* = stroke length

¹⁾ Always specify dimension "XV" in clear text on the order (observe XV_{min} and XV_{max})

Piston Ø 200 (dimensions in mm)

For explanations of items, see page 7

Type of mounting N Operating pressure 210 bar

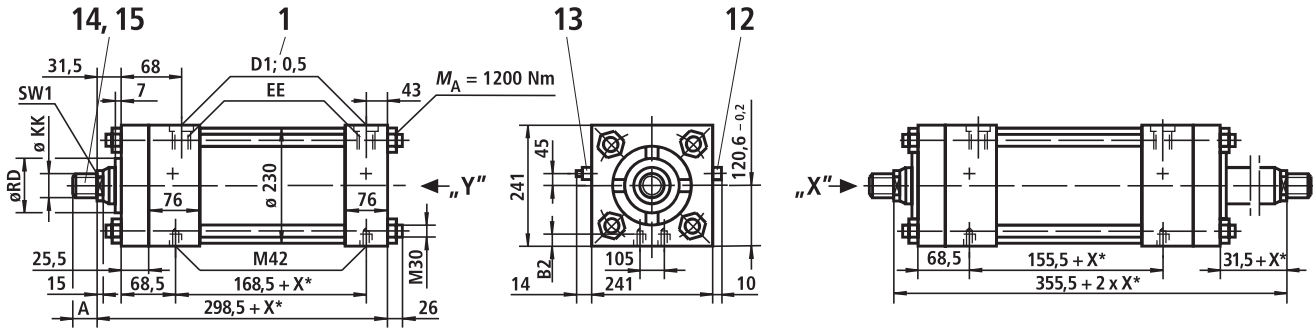

Stroke_{min} = 120 mm with thread version "E"
(only for double-rod cylinder)

Type of mounting T Operating pressure 210 bar

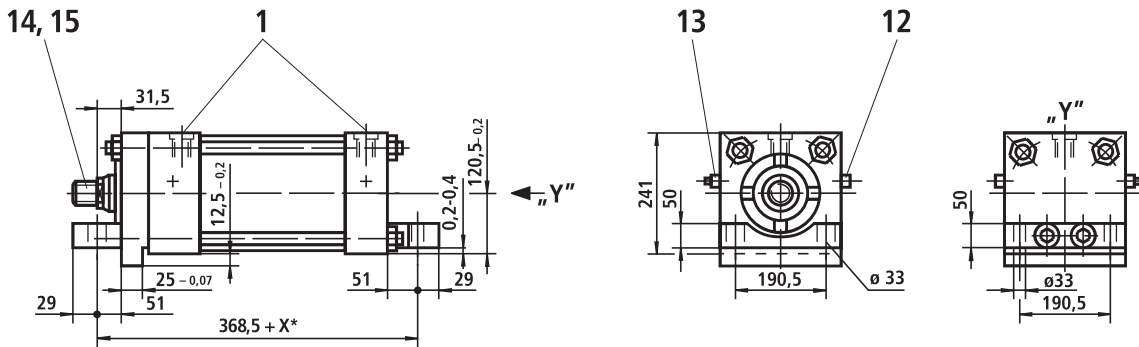

Type of mounting P Operating pressure 210 bar

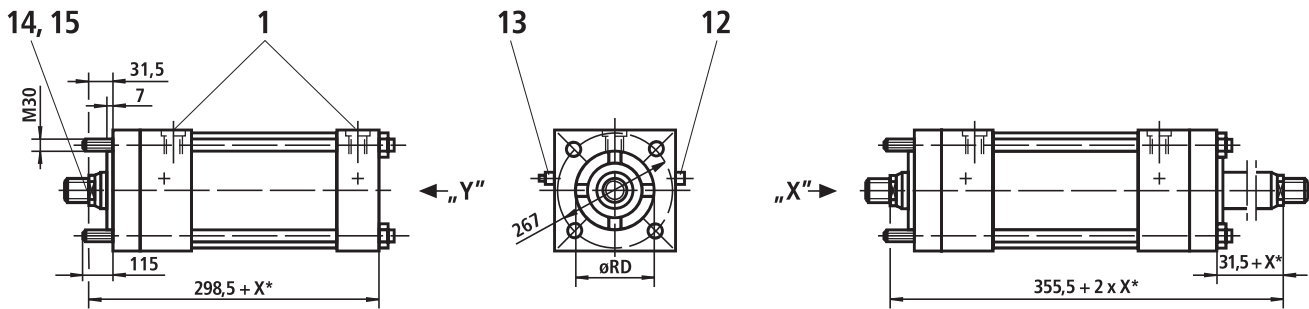

Stroke_{min} = 120 mm with thread version "E"
(only for double-rod cylinder)

Piston rod Ø	KK			A		EE				D1			
	Thread version			Thread version		Pipe connection				Pipe connection			
	C, E	B	F	C, E, B	F	01	13	02	14	01	13	02	14
90	M64 x 2	M76 x 2	M80 x 2	89	80	G1 1/2	-	M48 x 2	-	65	-	65	-
100	M76 x 2	M95 x 2	M80 x 2	101	80		-	-	-	-	-	-	-
140	M100 x 2	M130 x 2	M110 x 2	140	110		-	-	-	-	-	-	-

X* = stroke length

Piston Ø 200 (dimensions in mm)

For explanations of items, see page 7

Type of mounting **Q** Operating pressure 210 bar

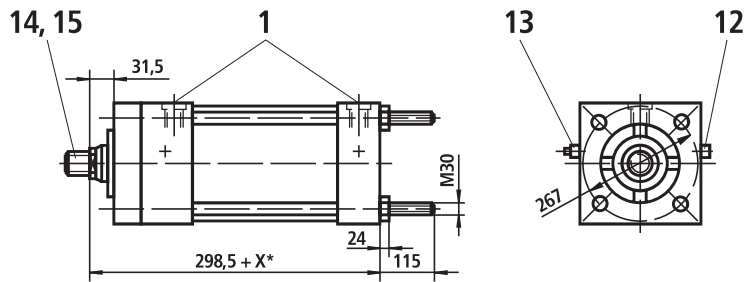

Additional thread versions

Thread version "E"

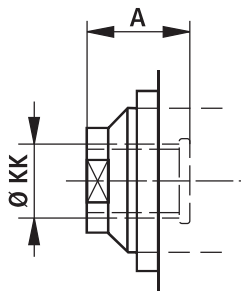

Thread version "F"

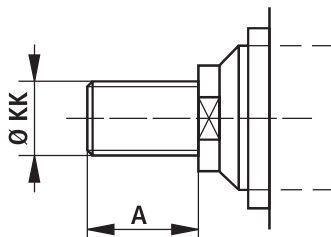

Self-aligning clevis CGA 80

suitable for thread version "F"
 Material no.: **R900303132**
 Weight: 12.2 kg
 Permissible load: 385 kN

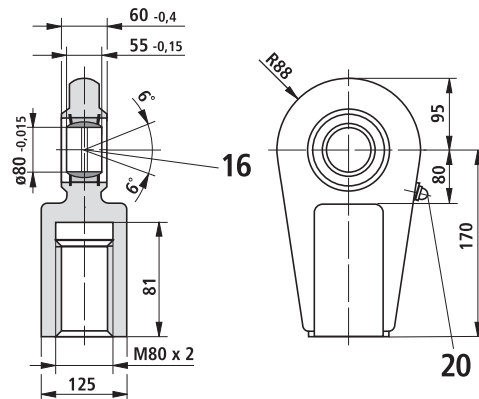

Self-aligning clevis CGA 110

suitable for thread version "F"
 Material no.: **R900303134**
 Weight: 27.5 kg
 Permissible load: 660 kN

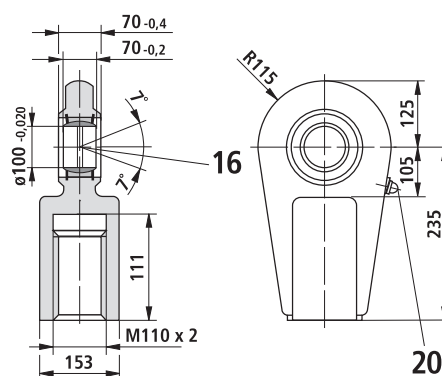

Piston rod Ø	ØRD f7							B2	SW1	Cushioning lengths	
										piston side	piston rod side
90	108							55	75	50	50
100	120							55	85		
140	158							32	120		

X* = stroke length

Weight

Piston Ø		40			50			63			
Piston rod Ø		16	18	25	22	25	36	25	28	36	45
Weight in kg per 100 mm stroke	Single-rod cylinder	0.55	0.6	0.8	0.9	1.0	1.3	1.6	1.7	2.0	2.4
	Double-rod cylinder	0.75	0.8	1.2	1.2	1.3	2.1	2.0	2.2	2.6	3.6
Type of mounting		CD		CG	CD		CG	CD		CG	
Weight in kg with 0 stroke	B	4.7		–	7.5		–	11.3		–	
	G	4.3		–	7.2		–	10.5		–	
	E	5.0		5.7	8.2		9.8	11.1		13.6	
	H	4.6		5.3	7.7		9.3	10.6		13.0	
	K, D	4.9		–	8.4		–	11.6		–	
	C, F, L, M, R, S, T	4.2		4.9	6.9		8.4	10.3		12.7	
	N, P, Q,	4.0		4.7	6.4		8.0	9.3		11.7	

Piston Ø		80			100			125			
Piston rod Ø		36	45	56	45	50	70	50	56	63	90
Weight in kg per 100 mm stroke	Single-rod cylinder	2.5	3.0	3.6	3.9	4.2	5.6	5.9	6.3	6.8	9.3
	Double-rod cylinder	3.3	4.2	5.5	4.1	5.8	8.6	7.8	8.2	9.3	14.3
Type of mounting		CD		CG	CD		CG	CD		CG	
Weight in kg with 0 stroke	B	21.0		–	29.5		–	54.7		–	
	G	19.5		–	28.6		–	48.2		–	
	E	21.3		25.5	28.3		35.1	49.5		60.5	
	H	20.0		24.0	27.3		34.0	48.8		61.0	
	K, D	21.8		–	27.7		–	52.5		–	
	C, F, L, M, R, S, T	18.7		23.0	25.6		33.0	45.0		57.3	
	N, P, Q,	17.3		21.3	23.8		30.5	42.5		54.7	

Piston Ø		150				180			200		
Piston rod Ø		63	70	80	100	80	90	125	90	100	140
Weight in kg per 100 mm stroke	Single-rod cylinder	7.9	8.4	9.4	11.5	11.6	12.7	17.3	15.2	16.4	22.2
	Double-rod cylinder	10.4	14.0	13.4	17.7	15.6	17.7	26.9	20.2	22.6	34.3
Type of mounting		CD		CG		CD		CG	CD		CG
Weight in kg with 0 stroke	B	81.3		–		132.2		–	181.5		–
	G	72.0		–		119.0		–	160.0		–
	E	76.5		91.5		117.5		142.0	165.0		197.0
	H	73.5		88.5		110.5		135.0	151.0		183.0
	K, D	80.6		–		120.0		–	162.5		–
	C, F, L, M, R, S, T	68.6		83.6		106.3		131.0	145.0		177.0
	N, P, Q,	66.0		81.0		101.3		126.0	140.0		172.0

CD = Single-rod cylinder

CG = Double-rod cylinder

Permissible stroke lengths

Piston Ø in mm	Piston rod Ø in mm	Mounting types: C, F, H, L, M, N, P, T				Mounting types: D, K, Q				Available maximum stroke length in mm (standard version)
		Operating pressure in bar				Operating pressure in bar				
		75	100	150	210	75	100	150	210	
		Permissible max. stroke in mm				Permissible max. stroke in mm				
40	16	560	470	370	295	195	155	105	70	1000
	18	745	635	505	415	285	230	170	130	
	25	1000	1000	1000	845	620	520	405	325	
50	22	880	750	595	490	340	280	205	155	1200
	25	1160	990	785	645	465	385	290	225	
	36	1200	1200	1200	1200	1090	925	730	600	
63	25	880	745	655	470	330	265	225	140	1400
	28	1145	975	775	640	460	380	285	220	
	36	1400	1400	1325	1100	820	690	535	430	
	45	1400	1400	1400	1400	1365	1165	920	755	
80	36	1505	1285	1025	845	615	510	390	305	1700
	45	1700	1700	1645	1365	1025	860	670	540	
	56	1700	1700	1700	1700	1670	1425	1130	925	
100	45	1875	1600	1275	1050	775	645	495	390	2000
	50	2000	1990	1585	1300	975	820	630	500	
	70	2000	2000	2000	2000	2000	1800	1430	1180	
125	50	1820	1545	1220	1000	735	610	455	350	2300
	56	2300	2005	1605	1325	990	830	640	510	
	63	2300	2300	2035	1680	1270	1070	830	665	
	90	2300	2300	2300	2300	2300	2300	1960	1625	
150	63	2450	2085	1655	1360	1010	845	645	505	2600
	70	2600	2600	2115	1755	1315	1110	865	700	
	80	2600	2600	2600	2280	1740	1465	1140	920	
	100	2600	2600	2600	2600	2600	2465	1965	1620	
180	80	2800	2800	2245	1845	1390	1165	895	710	2800
	90	2800	2800	2800	2515	1900	1615	1275	1044	
	125	2800	2800	2800	2800	2800	2800	2645	2195	
200	90	3000	3000	2690	2240	1675	1420	1120	910	3000
	100	3000	3000	3000	2845	2150	1830	1450	1190	
	140	3000	3000	3000	3000	3000	3000	2990	2485	

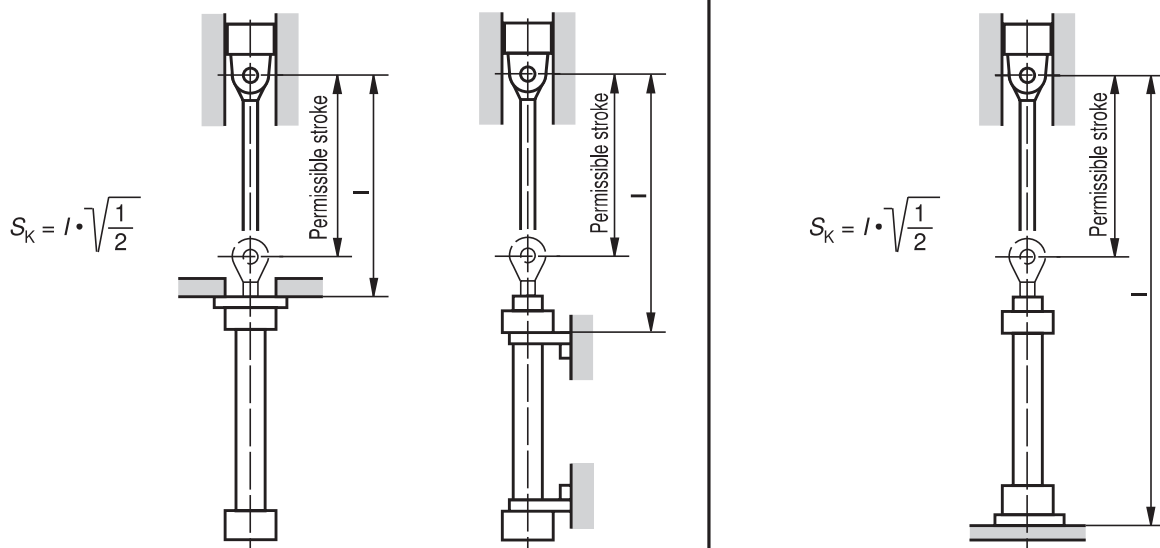

Permissible stroke lengths

Piston Ø in mm	Piston rod Ø in mm	Mounting types: B, G, S				Mounting types: E (Position: Trunnion at the center of the cylinder)				Available maximum stroke length in mm (standard version)
		Operating pressure in bar				Operating pressure in bar				
		75	100	150	210	75	100	150	210	
		Permissible max. stroke in mm				Permissible max. stroke in mm				
40	16	95	65	30	10	195	155	105	70	1000
	18	160	120	75	45	285	230	170	130	
	25	415	340	250	190	620	520	405	325	
50	22	195	150	95	60	340	280	205	155	1200
	25	295	235	160	115	465	385	290	225	
	36	760	635	490	390	1090	925	730	600	
63	25	185	140	105	45	330	265	225	140	1400
	28	280	220	150	105	460	380	285	220	
	36	555	455	340	260	820	690	535	430	
	45	960	810	630	505	1365	1165	920	755	
80	36	380	305	215	150	615	510	390	305	1700
	45	690	570	425	325	1025	860	670	540	
	56	1175	990	770	615	1670	1425	1130	925	
100	45	495	400	285	205	775	645	495	390	2000
	50	650	530	385	290	975	820	630	500	
	70	1495	1265	990	800	2000	1800	1430	1180	
125	50	455	360	245	165	735	610	455	350	2300
	56	640	525	380	285	990	830	640	510	
	63	855	700	525	400	1270	1070	830	665	
	90	2035	1730	1365	1115	2300	2300	1960	1625	
150	63	640	510	360	255	1010	845	645	505	2600
	70	865	710	530	405	1315	1110	865	700	
	80	1180	975	735	570	1740	1465	1140	920	
	100	2045	1725	1355	1095	2600	2465	1965	1620	
180	80	900	725	525	390	1390	1165	895	710	2800
	90	1280	1065	815	640	1900	1615	1275	1044	
	125	2740	2325	1840	1500	2800	2800	2645	2195	
200	90	1095	905	675	520	1675	1420	1120	910	3000
	100	1445	1205	920	725	2150	1830	1450	1190	
	140	3000	2630	2080	1700	3000	3000	2990	2485	

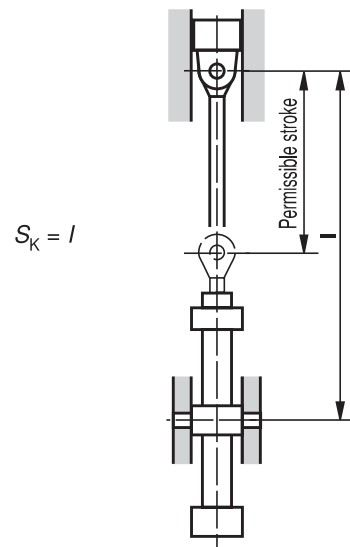
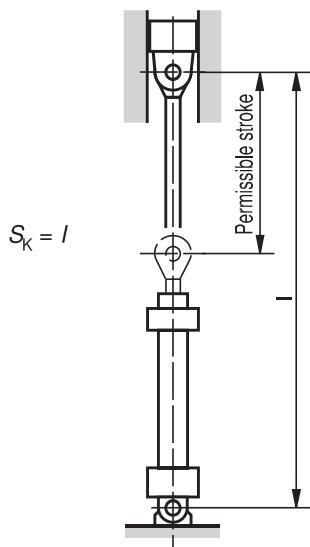

Permissible stroke lengths

Piston Ø in mm	Piston rod Ø in mm	Type of mounting: R				Available maxi- mum stroke length in mm (standard ver- sion)
		Operating pressure in bar				
		75	100	150	210	
		Permissible max. stroke in mm				
40	16	330	270	200	150	1000
	18	455	365	270	210	
	25	990	830	650	520	
50	22	545	450	325	250	1200
	25	770	620	480	380	
	36	1200	1200	1170	960	
63	25	540	445	380	255	1400
	28	735	610	455	350	
	36	1275	1080	845	685	
	45	1400	1400	1400	1210	
80	36	985	815	625	490	1700
	45	1585	1340	1055	855	
	56	1700	1700	1700	1480	
100	45	1240	1030	790	625	2000
	50	1515	1280	995	800	
	70	2000	2000	2000	1890	
125	50	1160	970	740	585	2300
	56	1585	1330	1025	815	
	63	1965	1660	1300	1050	
	90	2300	2300	2300	2300	
150	63	1585	1330	1030	825	2600
	70	2100	1775	1385	1120	
	80	2600	2265	1780	1445	
	100	2600	2600	2600	2590	
180	80	2160	1820	1415	1135	2800
	90	2680	2270	1790	1455	
	125	2800	2800	2800	2800	
200	90	2680	2270	1790	1455	3000
	100	3000	2825	2260	1865	
	140	3000	3000	3000	3000	

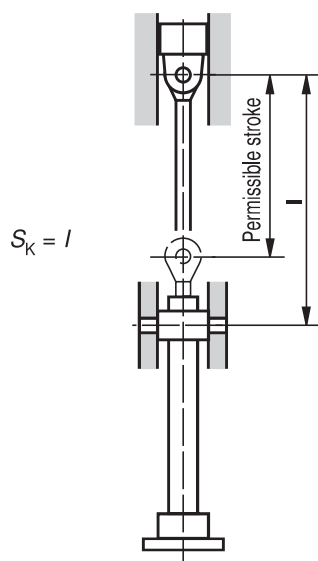

Calculation of buckling

Buckling calculations are usually carried out according to Euler, because piston rods are in most of the cases to be considered as slender rods

$$\text{Buckling load } K = \frac{\pi^2 \cdot E \cdot J}{s_K^2} \text{ in N}$$

i.e. under this load, the rod buckles!

$$\text{Max. operating load } F = \frac{K}{S} \text{ in N}$$

s_K = free buckling length in mm

E = modulus of elasticity in $\text{N/mm}^2 = 2.1 \cdot 10^5$ for steel

J = Mass moment of inertia in mm^4 for circular cross-section

$$= \frac{d^4 \cdot \pi}{64} = 0.0491 \cdot d^4$$

S = safety (3.5)

Stop tube extension

For long stroke and compressive loads, the use of a stop tube extension is recommended to avoid bearing stress when the piston rod is extended. With this solution, a spacer bushing

(3) is installed between piston (1) and cylinder head (2). This spacer bushing extends the lever arm, thus reducing the load on the bearings.

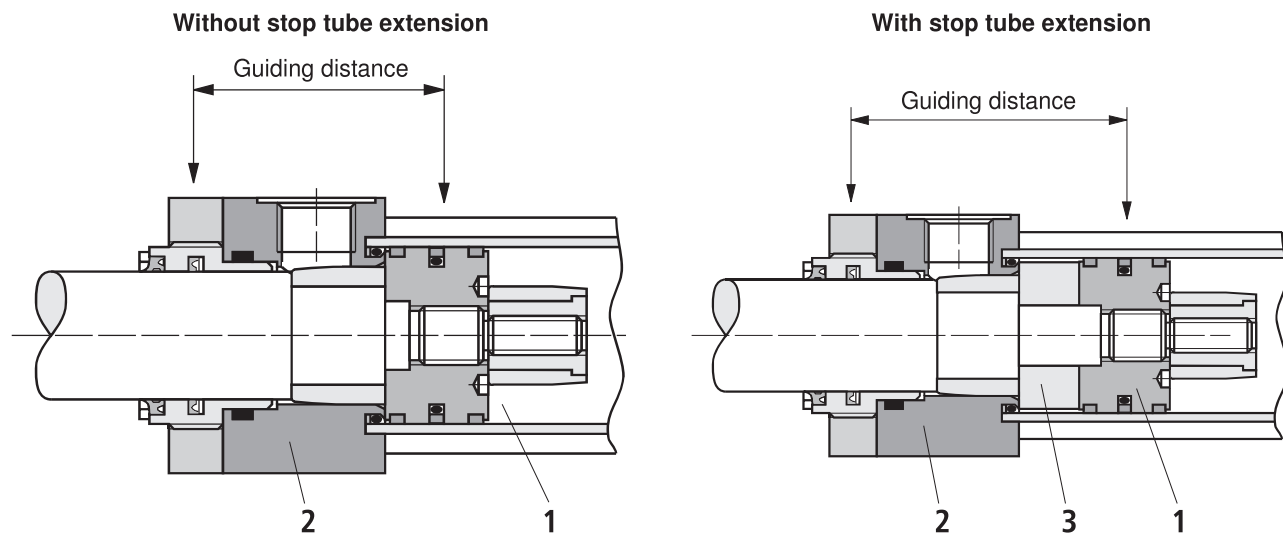

Ordering code	Stop tube extension in mm for all piston Ø							
	–	25	50	75	100	125	150	175
Type of mounting	Stroke length in mm							
B, G, S	Up to 500	501 to 625	626 to 750	751 to 875	876 to 1000	1001 to 1125	1126 to 1250	1251 to 3000
C, F, H, L	Up to 1425	1426 to 1785	1786 to 2150	2151 to 2500	2501 to 2860	2861 to 3000	–	–
D, E, K, Q	Up to 665	666 to 835	836 to 1000	1001 to 1165	1166 to 1335	1336 to 1500	1501 to 1665	1666 to 3000
R	Up to 1000	1001 to 1250	1251 to 1500	1501 to 1750	1751 to 2000	2001 to 2250	2251 to 2500	2501 to 3000
M, N, P, T	Up to 1425	1426 to 1785	1786 to 2150	2151 to 2500	2501 to 2860	2861 to 3000	–	–

Installation length of cylinder with stop tube extension:

Installation length according to unit dimensions + stop tube extension

(The trunnion position of type of mounting E and R remains unchanged.)

Installation lengths and position tolerances

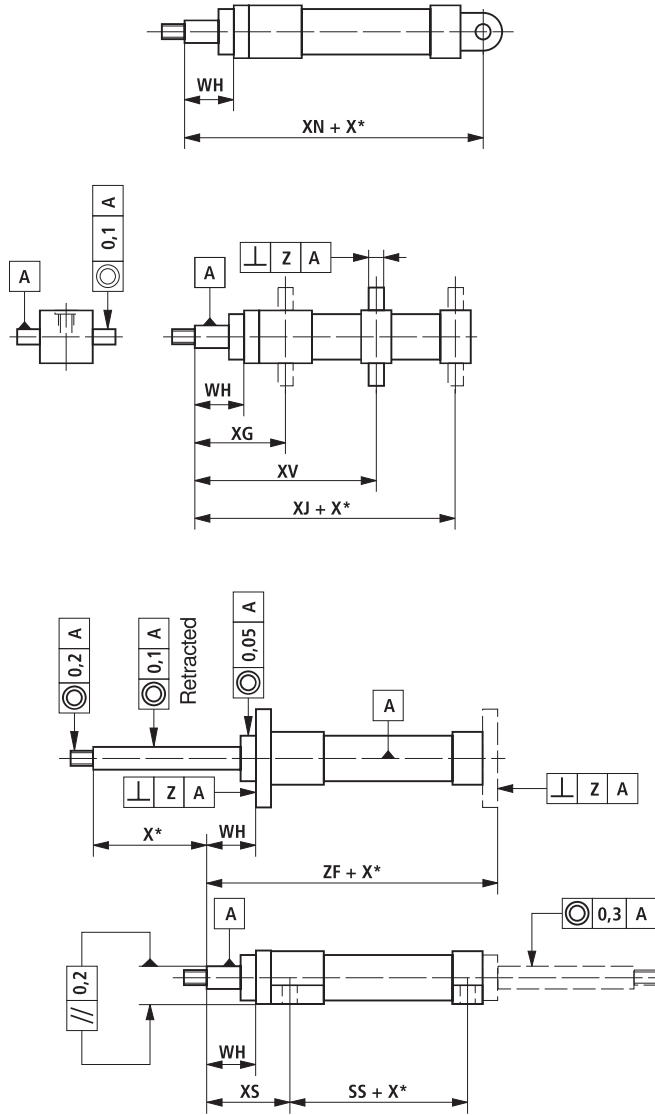

Stroke length in mm	Up to 1250	1251 to 2000	2001 to 3000
Stroke tolerance in mm	+1 -1.5	+1 -2	+1 -3
WH	±2	±2	+3 -2
ZF	±1	±1.5	±2
XS	±2	±2	+3 -2
SS	±1.25	+1.5 -2	+1.5 -3
XG	±2	±2	+3 -2
XV	±2	±2	±2
XJ	±2	±2	±2
XN	±1.25	±2	±2
Z	0.1 / 100		

Always specify dimension "XV" in clear text on the order (observe XV_{min} and XV_{max})

X^* = stroke length

Inductive proximity switch (please state in clear text on the order, dimensions in mm)

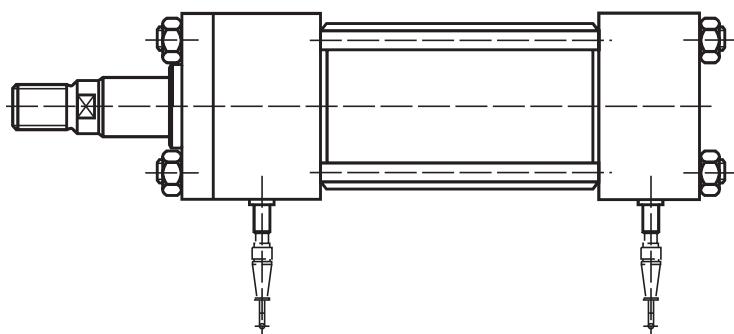

Types of mounting

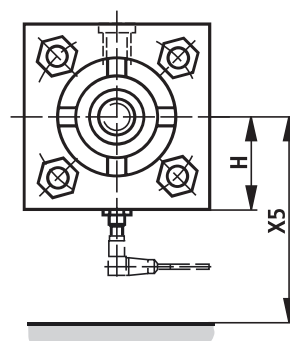
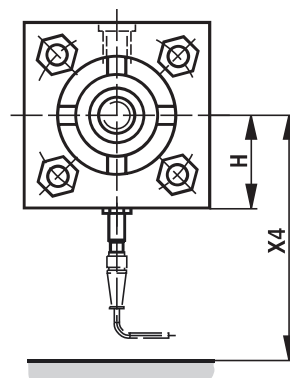

Mating connector with 5 m cable

Material no. **R900026512**

(Mating connector is **not** included in the scope of supply, but must be ordered separately)



Mating connector, angled with 5 m cable
(Position of cable outlet cannot be defined)

Material no. **R900021404**

(Mating connector is **not** included in the scope of supply, but must be ordered separately)

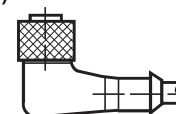

Piston Ø	Piston rod Ø	H	X4	X5
40	16	42.5	172	127
	18			
	25			
50	22	42.5	175	130
	25	48		
	36	180	135	
25	44.5			
28	53			
63	36	57	185	140
	45			
	56			
80	36	60	185	140
	45			
	56			

Piston Ø	Piston rod Ø	H	X4	X5
100	45	63.5	195	150
	50			
	70	67.5		
125	50	82.5	205	160
	56			
	63			
150	90	85	230	185
	63			
	70			
180	80	108	235	190
	70			
	80			
200	100	120.5	245	200
	80			
	100			
200	100	120.5	245	200
	140			
	100			

Notes:

- Installation position: 180° opposite to the line connections
- Pipe connection: For enlarged line connections, please consult us
- Type of mounting: With mounting types F, L, M, N and T, the installation 180° opposite to the line connection is impossible
- For mounting types and unit dimensions, see pages 8 to 61

Proximity switch

Inductive proximity switches are used for reliably checking the end positions of hydraulic cylinders. They are an important component for reliably and precisely monitoring safety equipment, locking mechanisms and/or other machine functions in their end position by issuing corresponding signals.

The proximity switch, which is high pressure-tight up to 500 bar, operates contact-free and floating. For this reason, it is wear-free. For safety reasons, the proximity switch is protected against being screwed in too deeply. The switching distance can therefore not be adjusted. Cylinder variants with proximity switch (option 1 "E") are fitted with proximity switches on both sides.

Technical data (for applications outside these parameters, please consult us!)

Operating principle		PNP normally open
Permissible pressure	bar	500
Operating voltage	V DC	10 to 30
Including residual ripple content	%	≤ 15
Voltage drop	V	≤ 1.5
Rated operating voltage	V DC	24
Rated operating current	mA	200
No-load current	mA	≤ 8
Residual current	μA	≤ 10
Repeatability	%	≤ 5
Hysteresis	%	≤ 15
Ambient temperature range	°C	-25 to +80
Thermal drift	%	≤ 10
Switching frequency	Hz	1000
Type of protection to	Active area	IP 68
DIN EN 60529	Proximity switch	IP 67
Housing material		Material no. 1.4104

Pinout

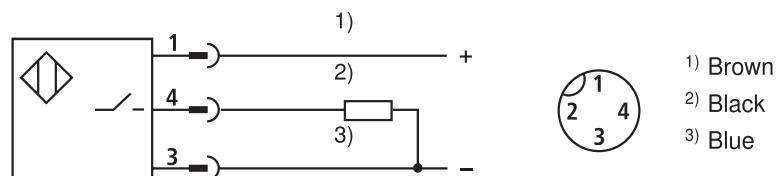

Seals (standard versions)

Piston rod seal

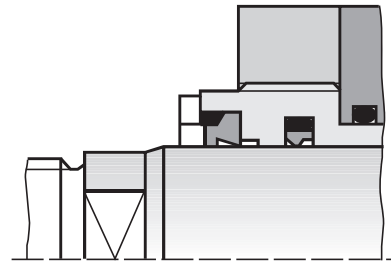
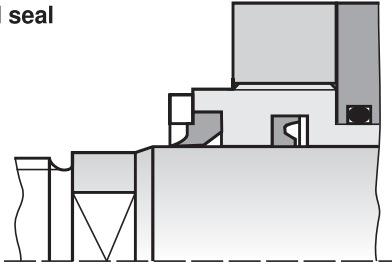

Variant for piston rod \varnothing 50, 63 and 80 mm

Piston seal

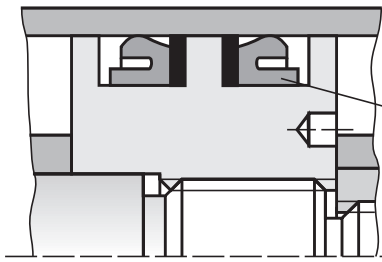

Version "T"

Slide ring for low-friction operation

Version "A"

Lip seal rings for leak-free operation under steady-state conditions

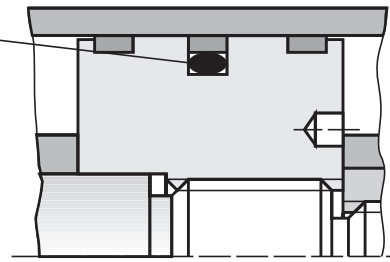

End position cushioning

End position cushioning at cylinder cap

Piston (1) is screwed directly to the piston rod, cushioning bush (2) by means of threaded bushing (3).

As the tapered cushioning bush retracts into the bore of cylinder cap (4) the cross-section for the fluid flowing out of piston chamber (5) reduces until it becomes zero. The fluid can then only flow out of piston chamber (5) through bore (6) and adjustable throttle valve (7). The cushioning effect can be regulated on throttle valve (7). The smaller the flow cross-section, the greater the effect of end position cushioning.

Adjustable throttle valve for end position cushioning

The design of the throttle valve prevents throttling pin (8) from being turned out completely when end position cushioning is adjusted.

The setting made for end position cushioning is secured by locknut (9).

Check valve with bleed screw

Check valve (10) serves as extension aid from the end position. It by-passes the throttling point while the cylinder is extending.

The cylinder is bled via bleed screw (11).

This bleed screw is provided as standard on cylinders without end position cushioning.

Throttle valve and check valve are designed as installation kits and can be interchanged.

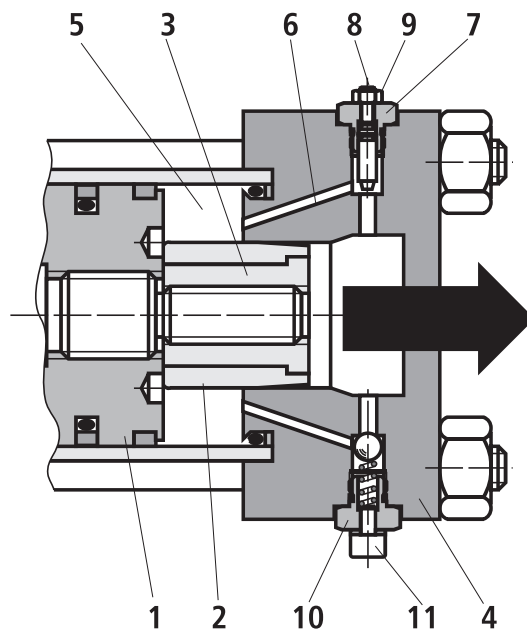

Calculation of braking force

End position cushioning must ensure a controlled deceleration (braking) of the stroke velocity in both end positions.

The total of the effective energies must not exceed the maximum work capacity of cushioning.

The energy to be decelerated is converted into heat in the cushioning zone, which operates according to the principle of fluid flow throttling.

Calculation of braking force

The braking force of a horizontally installed hydraulic cylinder can be calculated as follows:

Extension movement:

$$F_B = m \cdot a + A_K \cdot p$$

F_B = braking force in N

m = moved mass in kg

a = deceleration in m/s^2

$$a = \frac{v^2}{2 \cdot s}$$

Retraction movement

$$F_B = m \cdot a + A_R \cdot p$$

v = stroke velocity in m/s

s = cushioning length in m

A_K = piston area in cm^2

A_R = annulus area in cm^2

p = system pressure in N/cm^2

$$1 \text{ bar} \sim 10 \text{ N/cm}^2$$

For vertical strokes of the cylinders, the weight force (consisting of external load, piston and piston rod) must be added to or subtracted from braking force F_B depending on the direction of movement.

The cylinder's internal friction is neglected in this calculation.

Calculation of the average cushioning pressure

Under normal operating conditions, the cushioning pressure must not exceed the nominal pressure of the cylinder.

$$p_D = \frac{F_B}{A_D}$$

p_D = average cushioning pressure in N/cm^2

F_B = braking force in N

A_D = effective cushioning area in cm^2

$$1 \text{ bar} \sim 10 \text{ N/cm}^2$$

If this calculation results in too high a value, the cushioning length must be extended or the system pressure reduced.

Spare parts drawing

Variant for piston
Ø
40 to 200

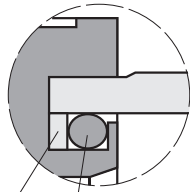

1 Head	6 Guide bush	11 Tie rod	33 Wiper
2 Cap	7 Piston	19 Nut	34 Piston rod seal
3 Piston rod	8 Cushioning bush	20 Guide band	35 Seal ring
4 Cylinder barrel	9 Cushioning bush	21 Piston seal (variant "T")	36 Back-up ring
5 Flange	10 Threaded bushing		37 Seal ring

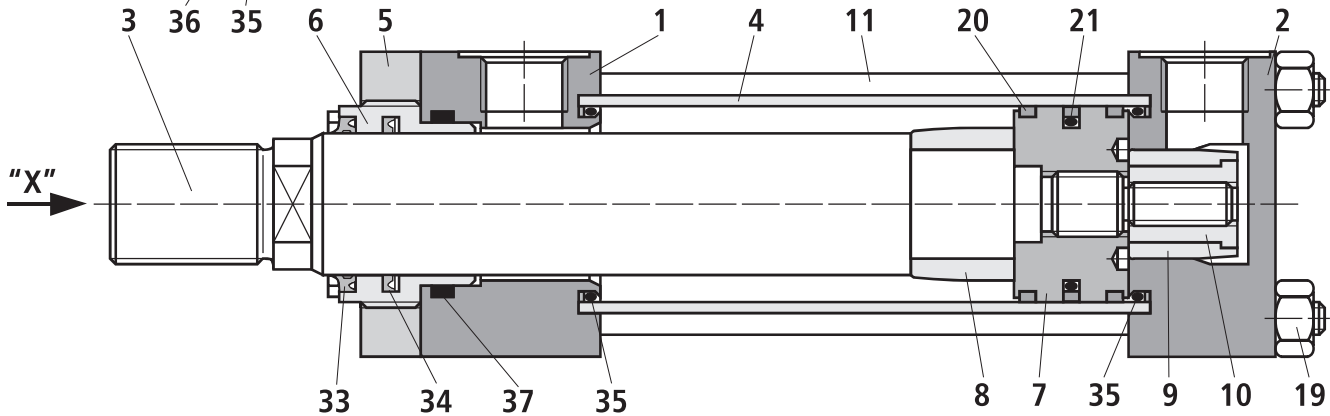

Throttle and check valve in cylinder head and cylinder cap

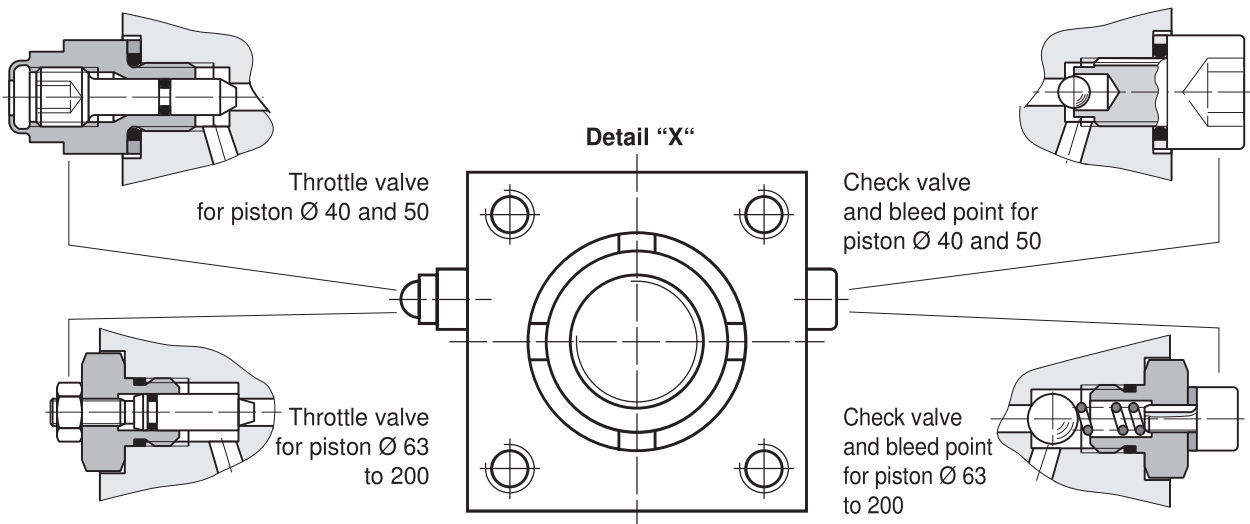

Ordering spare parts:

- When ordering individual parts, please indicate the designation and item no. from the spare parts drawing with complete type code of the hydraulic cylinder
- For seal kits, please indicate the complete type code of the hydraulic cylinder.

© This document, as well as the data, specifications and other information set forth in it, are the exclusive property of Bosch Rexroth AG. It may not be reproduced or given to third parties without its consent. The data specified above only serve to describe the product. No statements concerning a certain condition or suitability for a certain applica-

tion can be derived from our information. The information given does not release the user from the obligation of own judgment and verification. It must be remembered that our products are subject to a natural process of wear and aging.

Bosch Rexroth AG
Hydraulics
Zum Eisengießer 1
97816 Lohr am Main, Germany
Phone +49 (0) 93 52 / 18-0
Fax +49 (0) 93 52 / 18-23 58
documentation@boschrexroth.de
www.boschrexroth.de

Bosch Rexroth Teknik AB
Varuvägen 7, Älvsjö
S-125 81 Stockholm
Phone +46 (08) 72 79 20 0
Fax +46 (08) 86 87 21
cyl.hyd@boschrexroth.se
www.boschrexroth.se

Bosch Rexroth SA
BP 37 - Z.I. Les Fourmis
F-74131 Bonneville Cedex
Phone +33 (0) 4 50 25 35 45
Fax +33 (0) 4 50 25 35 19
www.boschrexroth.fr