

Diaphragm accumulators



1. DESCRIPTION

1.1. FUNCTION

While fluids are practically incompressible, this does not apply to gases. Hydraulic accumulators use these basic laws of physics to store hydraulic energy. Nitrogen is normally used as the compressible medium.

The various types of hydraulic accumulator are categorised on the basis of the separation element that keeps the gas section separate from the fluid section in the pressure vessel. In the case of diaphragm accumulators, this is an elastomer diaphragm or a full-PTFE diaphragm. Set into the base of the diaphragm is a valve plate. This shuts off the hydraulic outlet when the accumulator is completely empty and thus prevents damage to the diaphragm.

The fluid side of the diaphragm accumulator is connected to the hydraulic circuit so that the diaphragm accumulator draws in fluid when the system pressure increases and the trapped gas is compressed. When the system pressure drops, the compressed gas expands and forces the stored fluid back out into the hydraulic circuit.

Diaphragm accumulators can also be used as dampers, for example – see catalogue section:

- Hydraulic dampers
No. 3.701



1.2. DESIGN

HYDAC weld type diaphragm accumulators consist of the following key individual components:

- Welded pressure vessel, rechargeable on the gas side or, alternatively, completely sealed, valve body
- Diaphragm to separate the fluid and gas sections
- Valve plate in diaphragm base

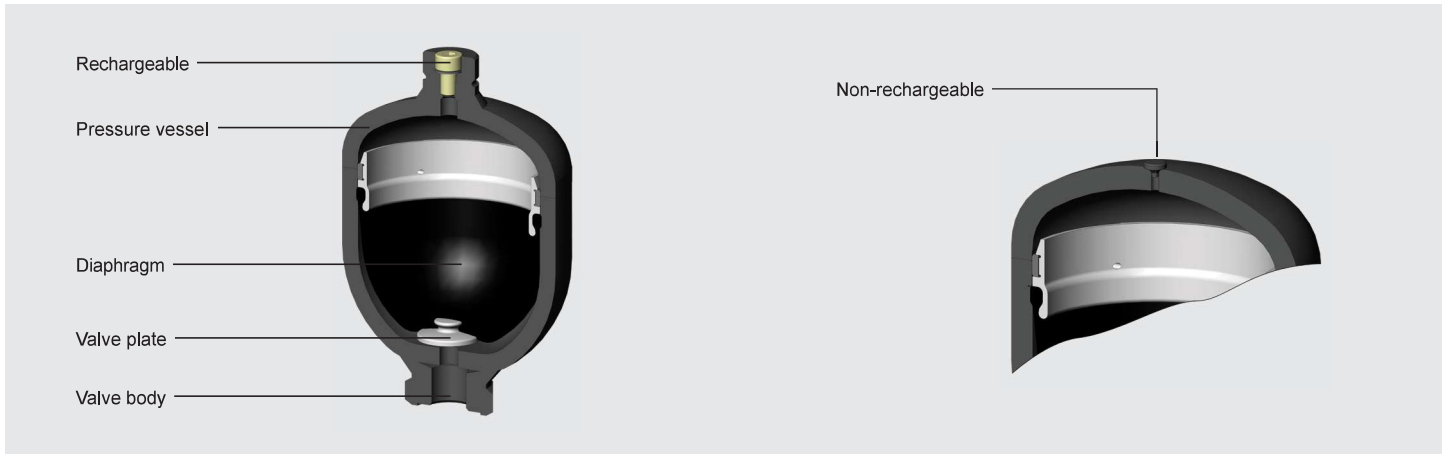

HYDAC screw type diaphragm accumulators consist of the following key individual components:

- Forged upper section with gas charging connection
- Forged lower section with valve body
- Exchangeable diaphragm to separate the gas section and fluid
- Valve plate in diaphragm base
- Lock nut to hold the upper and lower sections of the accumulator together

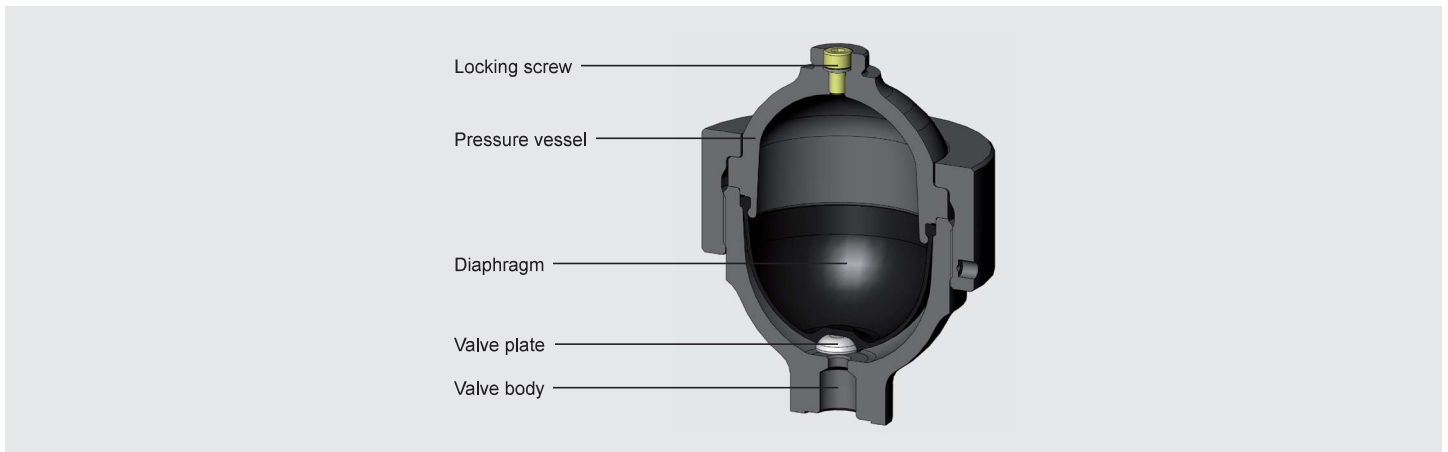

2. GENERAL INFORMATION

2.1. MATERIALS, CORROSION PROTECTION

2.1.1 Accumulator shell

As standard, the upper and lower sections are made from carbon steel.

For use with chemically aggressive fluids the hydraulic accumulator can be supplied with corrosion protection, such as plastic coating or a galvanic or chemical surface protection. If this is insufficient, then almost all types can be supplied in stainless steel.

2.1.2 Diaphragm

The diaphragm material must be selected in accordance with the particular operating medium or operating temperature, see section 2.1.3.

If discharge conditions are unfavourable (high p_2/p_0 pressure ratio, rapid discharge speed), the gas may cool to below the permitted temperature. This can cause cold cracking. The gas temperature can be calculated using the HYDAC Accumulator Simulation Program **ASP**.

2.1.3 Maximum temperature range of elastomer materials

The permitted working temperature of a diaphragm accumulator is dependent on the application of the metal materials and the diaphragm. The operating medium must also be taken into account.

The following table shows the main **elastomer materials with their maximum possible temperature ranges** with examples of operating fluids.

Materials		Material code ¹⁾	Max. possible temperature range ²⁾	Possible operating fluids, others on request	
				Resistant to	Not resistant to
NBR	Acrylonitrile butadiene rubber	2	-15 °C ... + 80 °C	<ul style="list-style-type: none"> - Mineral oil (HL, HLP) - Flame-retardant fluids from the groups HFA, HFB, HFC - Synthetic esters (HEES) 	<ul style="list-style-type: none"> - Aromatic hydrocarbons - Chlorinated hydrocarbons (HFD-S) - Amines and ketones
		5	-50 °C ... + 50 °C	<ul style="list-style-type: none"> - Water - Sea water 	<ul style="list-style-type: none"> - Hydraulic fluids from the group HFD-R - Fuels
ECO	Ethylene oxide epichlorohydrin rubber	3	-40 °C ... +120 °C	<ul style="list-style-type: none"> - Mineral oil (HL, HLP) - Flame-retardant fluids from the HFB group - Synthetic esters (HEES) - Water - Sea water 	<ul style="list-style-type: none"> - Aromatic hydrocarbons - Chlorinated hydrocarbons (HFD-S) - Amines and ketones - Hydraulic fluids from the group HFD-R - Flame-retardant fluids from the groups HFA and HFC - Fuels
IIR	Butyl rubber	4	-50 °C ... +120 °C	<ul style="list-style-type: none"> - Hydraulic fluids from the group HFD-R - Flame-retardant fluids from the group HFC - Water 	<ul style="list-style-type: none"> - Mineral oils and greases - Synthetic esters (HEES) - Aliphatic, chlorinated and aromatic hydrocarbons - Fuels
FKM	Fluoroelastomer rubber	6	-10 °C ... +150 °C	<ul style="list-style-type: none"> - Mineral oil (HL, HLP) - Hydraulic fluids from the group HFD - Synthetic esters (HEES) - Fuels - Aromatic hydrocarbons - Inorganic acids 	<ul style="list-style-type: none"> - Amines and ketones - Ammonia - Skydrol and HyJet IV - Steam

¹⁾ The material code (MC) is described in more detail in the model code, see section 3.

²⁾ The specified temperature range relates to the particular elastomer material, not to the operating range of the hydraulic accumulator, see section 4.1.1

2.2. INSTALLATION POSITION

Any position can be chosen. However, if there is a risk of contamination collecting, a vertical position is preferable (fluid port at the bottom).

2.3. TYPE OF INSTALLATION

Diaphragm accumulators up to a nominal volume of 2 l can be screwed directly inline. Where strong vibrations are expected, the hydraulic accumulator must be secured to prevent it working loose.

For strong vibrations and volumes above 2 litre, we recommend HYDAC mounting elements – see catalogue section:

- Mounting elements for hydraulic accumulators
No. 3.502

2.4. CHARGING GAS

- Charging gas: Nitrogen
- Specification: min. Class 2.8

If other gases are to be used or if these specifications are deviated from, please contact HYDAC.

2.5. HYDRAULIC FLUID

Hydraulic accumulators must only be operated with operating fluids with a minimum cleanliness class of:

- NAS 1638 Class 6 or
- ISO 4406 Class 17/15/12

2.6. CERTIFICATES

Hydraulic accumulators that are installed outside of Germany are supplied with the relevant test certificate documentation. The country of installation must be stated at the time of ordering. HYDAC pressure vessels can be supplied with almost any approval classification. The permitted operating pressure may differ from the nominal pressure.

The following table provides some examples of the code in the model code:

Country	Certificate code (CC)
EU member states	U
Australia	F ¹⁾
Belarus	A6
Canada	S1 ¹⁾
China	A9
Great Britain	Y
Hong Kong	A9
Iceland	U
Japan	P
Korea (Republic of)	A11
New Zealand	T
Norway	U
Russia	A6
South Africa	S2
Switzerland	U
Turkey	U
Ukraine	A10
USA	S

¹⁾ Registration required in the individual territories or provinces.
Others on request

2.7. FURTHER INFORMATION

- Operating instructions for diaphragm accumulators
No. 3.100.BA

The operating instructions must be observed!

All work on HYDAC diaphragm accumulators must only be carried out by suitably trained staff. Incorrect installation or handling can lead to serious accidents.

- Assembly and repair instructions for diaphragm accumulators
No. 3.100.M

For repairs to be performed on hydraulic accumulators, we provide corresponding assembly and repair instructions.

Further information such as accumulator sizing, safety information and extracts from the acceptance specifications can be found in our overview catalogue section:

- HYDAC Accumulator Technology
No. 3.000

This document and others are available from our Download Center at www.hydac.com.

3. MODEL CODE

Not all combinations are possible. Order example.
For further information, please contact HYDAC.

SBO210 - 2 E1 / 112 U - 210 AK 050

Series

Nominal volume [l]

Type

Weld type (diaphragm not exchangeable)

- E1 = rechargeable M28x1.5
- E2 = sealed gas connection, with gas pre-charge as requested ¹⁾
- E3 = rechargeable, gas valve M16x1.5 / M14x1.5

Screw type (exchangeable diaphragm)

- A6 = rechargeable M28x1.5
- A3 = gas valve M16x1.5 / M14x1.5

Material code (MC)

Dependent on operating medium
Standard design = 112 for mineral oil
Others on request

Fluid port

- 1 = carbon steel
- 3 = stainless steel ²⁾
- 4 = carbon steel with protective coating ³⁾
- 6 = low-temperature steel
- 7 = other materials

Accumulator shell

- 1 = carbon steel
- 2 = carbon steel with protective coating ^{3) 4)}
- 4 = stainless steel ²⁾
- 6 = low-temperature steel
- 7 = other materials or material combinations

Diaphragm

- 2 = NBR ⁵⁾
- 3 = ECO
- 4 = IIR
- 5 = NBR ⁵⁾
- 6 = FKM
- 7 = other materials (e.g. PTFE, EPDM)

Certification code

U = European Pressure Equipment Directive (PED)
For others, see section 2.6.

Permitted operating pressure [bar]

Fluid port form

Standard connection = AK or AB
e.g. form AK = G 3/4
for SBO210-2, see section 4.2.

Pre-charge pressure p_0 [bar] at 20 °C, must be stated clearly, if required! ¹⁾

¹⁾ Only for E1 or E2 design, when ordered as standard

²⁾ Dependent on type and pressure rating

³⁾ Only for screw type design

⁴⁾ Only for parts that come into contact with the fluid

⁵⁾ Observe temperature ranges, see section 2.1.3.

4. STANDARD ITEMS

4.1. TECHNICAL DATA

The diaphragm accumulators and spare parts described below are manufactured in carbon steel or stainless steel with an NBR diaphragm (MC = 112 / 342).

The table provides the most important data and dimensions for the following series:

SBO50/100/140/160/180/210/250/300/330/400/450/500/750

The data provided refers to diaphragm accumulators in accordance with PED (CC = U).

Designs that differ from the standard types described below can be requested from HYDAC.

4.1.1 Permitted operating temperature

As standard, a diaphragm accumulator can be operated in the following temperature range:

-10 °C ... +80 °C

Other operating temperatures on request.

4.1.2 Permitted operating pressure

The permitted operating pressure may differ from the nominal pressure in the case of other certifications. The tables in section 4.2. show the permitted operating pressure in accordance with the European Pressure Equipment Directive.

4.1.3 Nominal volume

HYDAC diaphragm accumulators are available with set nominal volumes, as described in the tables in section 4.2.

4.1.4 Effective gas volume

The effective gas volume corresponds to the nominal volume of the diaphragm accumulator.

4.1.5 Effective volume

Volume of fluid which is available between the operating pressures p_2 and p_1 .

4.1.6 Maximum flow rate of the operating fluid

In order to achieve the max. flow rate given in the tables, a residual fluid volume of approx. 10 % of the effective gas volume must remain in the accumulator.

The maximum fluid flow rate was determined under specific conditions and is not applicable in all operating conditions.

4.1.7 Limits for gas pre-charge pressure

$$p_0 \leq 0.9 \cdot p_1$$

with the permitted pressure ratio specified in the tables in section 4.2. (= ratio of max. operating pressure p_2 to gas charging pressure p_0).

The specified values are maximum values and must not be considered as referring to a permanent load. The sustainable pressure ratio is affected by geometry, temperature, medium, flow rate and gas losses resulting from physical characteristics.

For diaphragm accumulators with full-PTFE diaphragm, the following applies:

$$p_{0\text{max}} \leq 200 \text{ bar}$$

For more information, see catalogue section:

- HYDAC Accumulator Technology
No. 3.000

4.2. TABLES AND DRAWINGS

4.2.1 Screw type

– exchangeable diaphragm –

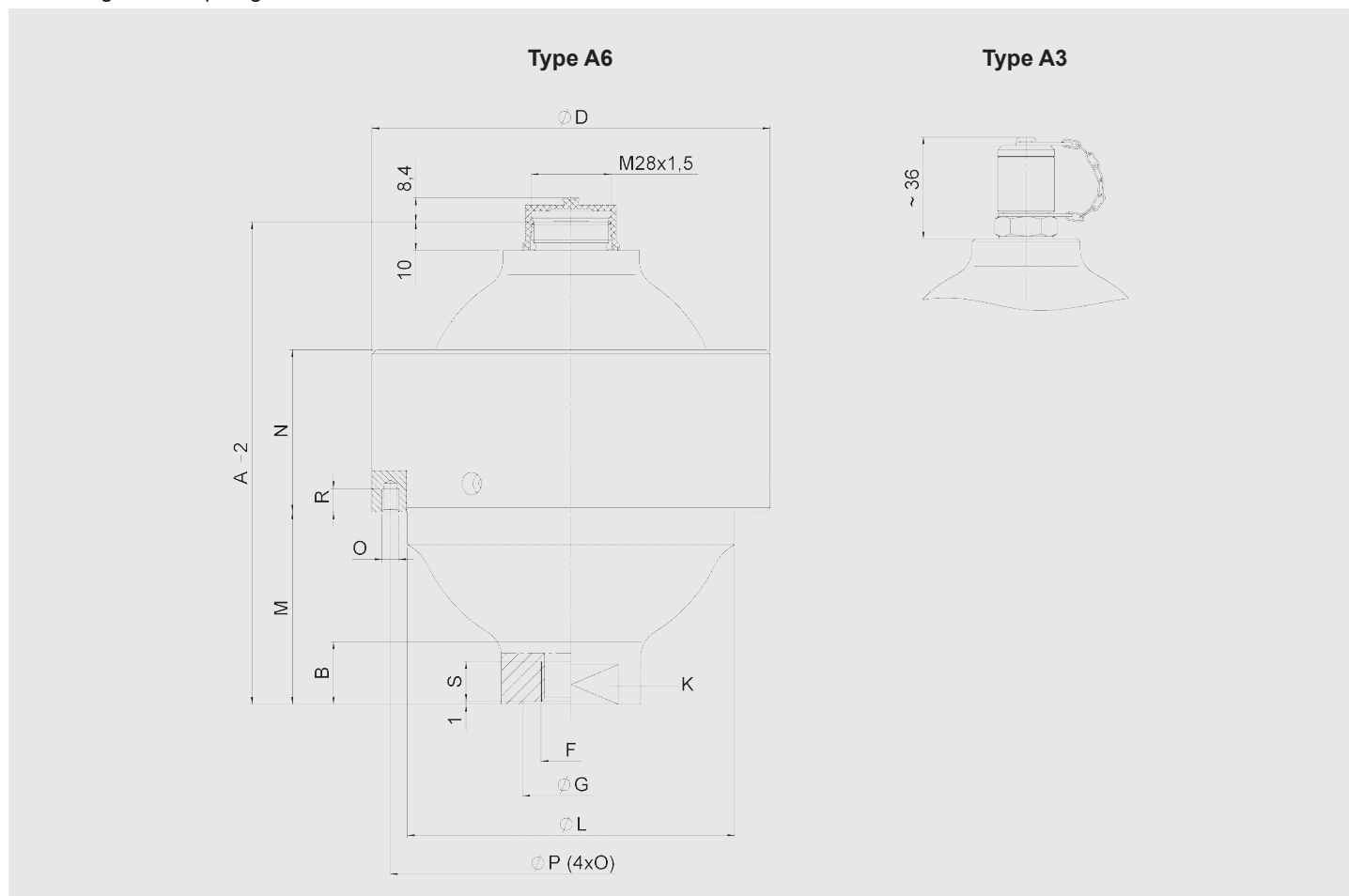

Nom. vol. [l]	Perm. press. ratio $p_2 : p_0$	Series	Perm. oper. pressure [bar]		Weight [kg]	A [mm]	B [mm]	ØD [mm]	ØL [mm]	M [mm]	N [mm]	O	ØP [mm]	R [mm]	Q ¹⁾ [l/min]	Fluid port			
			Carbon steel	Stainless steel												Form AK			
																F ISO 228	S [mm]	ØG [mm]	K AF
0.1	10:1	500	500	–	1.9	110	30	95	–	53	35	–	–	–	95	G 1/2	14	–	36
0.25	10:1	500	500	–	3.9	129	20	115	92	56	63	–	–	–	95	G 1/2	14	–	36
			–	350	4.9			125										60	
0.6	10:1	450	450	250	5.7	170	19	140	115	68	57	–	–	–	95	G 1/2	14	34	41
1.3	10:1	400	400	–	11.2	212	28	199	160	97	65	M8	180	10	150	G 3/4	16	44	50
2	10:1	250	250	180	11.4	227	17	201	168	101	64	M8	188	10	150	G 3/4	16	44	50
2.8	10:1	400	400	–	22	257	30	252	207	106	80	M8	230	10	150	G 3/4	16	44	50
4	10:1	400	400	–	34	284	30	287	236	127.5	90	M8	265	10	150	G 3/4	16	44	50

¹⁾ Max. flow rate of operating fluid

4.2.2 Weld type
 – non-exchangeable diaphragm –

Fig.	Design	Gas side connection			Fluid side connection	
		E1	E2	E3	AK	AB
1						
2			I			
3			On request			
4			I			

Nom. vol.	Perm. press. ratio	Series	Perm. oper. pressure [bar]		R [mm]	ØD [mm]	Weight [kg]	Q ¹⁾ [l/min]	Fluid port										Fig.
			Carbon steel	Stainless steel					Form AK					Form AB					
									F ISO 228	ØG [mm]	L [mm]	B1 [mm]	Hex. AF	F ISO 228	H DIN 13	L [mm]	B2 [mm]	Hex. AF	
[l]	p ₂ : p ₀																		
0.075	8:1	250	250	—	91	64	0.7	38	G 1/2	—	14	21	30	Not available					1
0.16	8:1	210	210	180	103	74	0.8	38	G 1/2	—	14	21	30						1
		300	300	—	108	78	1.1												
0.32	8:1	100	100	—	116	90	0.9	95	G 1/2	—	14	21	30	1					
		210	210	160		93	1.3												
		300	300	—		120	96								1.8				
0.5	8:1	160	160	—	130	102	1.3	95	G 1/2	—	14	21	30	G 1/2	M33x1.5	14	37	41	1
		210	210	—	133	105	1.7												
0.6	8:1	330	330	—	151	115	3.3	95	G 1/2	34	14	21	41	G 1/2	M33x1.5	14	37	41	1
		350	350	—	130	121	3.5												
0.7	8:1	100	100	—	151	106	1.8	95	G 1/2	34	14	21	41	G 1/2	M33x1.5	14	37	41	1
0.75	8:1	140	140	—	142	116	1.8	95	G 1/2	34	14	21	41	G 1/2	M33x1.5	14	37	41	1
		210	210	140	147	121	2.8												
		250	250	—	152	126	3.6					26	42			3			
		330	330	—	140	126	4												
1	8:1	200	200	—	159	136	3.6	95	G 1/2	34	14	21	41	G 1/2	M33x1.5	14	37	41	1
		250	250	—	192	126	4.4												
	330	330	—	169	126	4.8													
1.4	8:1	140	140	—	173	145	3.9	95	G 1/2	34	14	21	41	G 1/2	M33x1.5	14	37	41	1
		210	210	—	178	150	5.4												
		250	250	—	185	153	5.9					33	42			3			
		330	330	—	172	155	7.6												
2	8:1	100	100	100	190	160	4	150	G 3/4	44	16	28	46	G 3/4	M45x1.5	16	33	46	1
		210	210	—	198	167	6.6												
	250	250	—	232	153	7.4	43					42	3						
330	330	—	181	172	9.2														
2.8	4:1	210	210	—	250	167	8.2	150	G 3/4	44	16	28	46	G 3/4	M45x1.5	16	33	46	2
		250	250	—	250	170	9.5												
	330	330	—	237	172	11	44					42	3						
3.5	4:1	250	210	—	306	170	11.2	150	G 3/4	44	16	28	46	G 3/4	M45x1.5	16	33	46	2
		330	330	—	274	172	13.8												
4	4:1	50	—	50	294	158	5	150	G 3/4	44	16	44	46	G 3/4	M45x1.5	16	33	46	2
		250	—	180	306	170	11.2												

¹⁾ Max. flow rate of operating fluid

4.3. SPARE PARTS

4.3.1 Weld type

– exchangeable diaphragm –

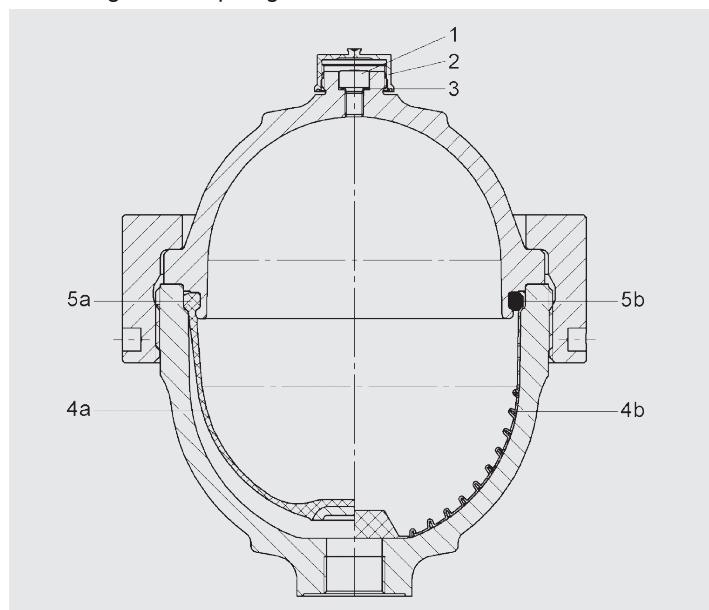

Description	Qty.	Item
-------------	------	------

Spare parts set for gas side

consisting of:

Locking screw	20	1
Protective cap	20	2
Seal ring	20	3

Spare parts kit for elastomer diaphragm

consisting of:

Locking screw	1	1
Seal ring	1	3
Elastomer diaphragm	1	4a
Support ring	1	5a

Spare part kit for full-PTFE diaphragm

consisting of:

Locking screw	1	1
Seal ring	1	3
Full-PTFE diaphragm	1	4b
O-ring	1	5b

Nominal volume [l]	Part no.				
	NBR	ECO	FKM	IIR	PTFE

Spare parts set for gas side

0.1 - 4	3262845	-	-	-	-
---------	---------	---	---	---	---

Spare parts kit

0.1	3042668	3182526	-	-	-
0.25	3042709	3042712	3042714	3042713	3504798
0.6	3042710	3042715	3042717	3042716	3550388
1.3	3042681	3042682	3042684	-	3446897
2	3042711	3042719	3042721	3042720	3464205
2.8	3042700	3042701	3042704	3042702	-
4	3042705	3042706	3042708	3042707	-

4.3.2 Weld type

– non-exchangeable diaphragm –

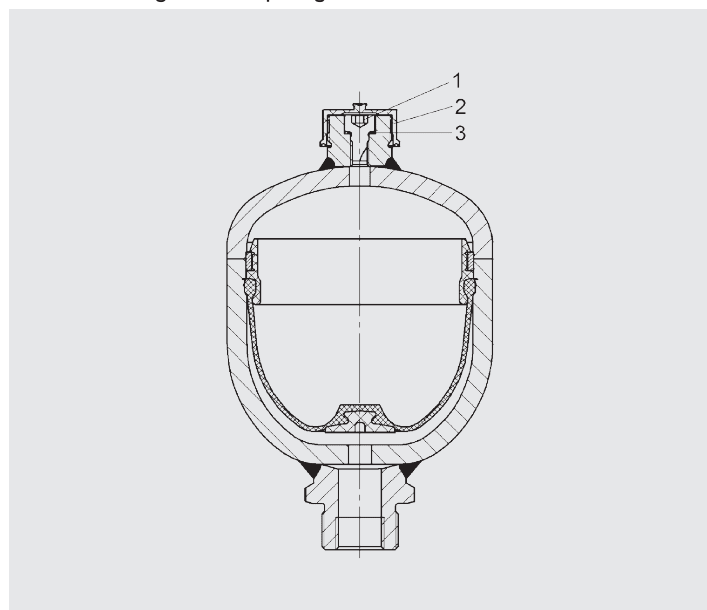

Description	Qty.	Item
-------------	------	------

Spare parts set for gas side

consisting of:

Locking screw	20	1
Protective cap	20	2
Seal ring	20	3

Nominal volume [l]	Part no.				
	NBR	ECO	FKM	IIR	PTFE

Spare parts set for gas side

0.075 - 4	3262845	-	-	-	-
-----------	---------	---	---	---	---

5. NOTE

The information in this brochure relates to the operating conditions and fields of application described. For applications and/or operating conditions not described, please contact the relevant technical department. Subject to technical modifications.

HYDAC Technology GmbH

Industriegebiet

66280 Sulzbach/Saar, Germany

Tel.: +49 68 97 / 509 - 01

Internet: www.hydac.com

E-mail: speichertechnik@hydac.com