

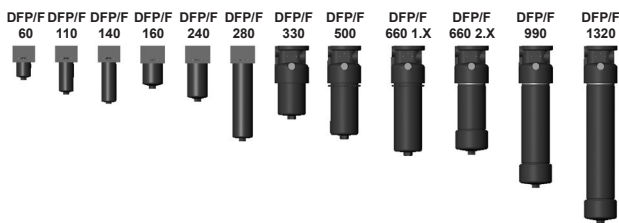

## Pressure Filter for Manifold Mounting DFP and for Reversible Flow DFPF up to 620 l/min, up to 315 bar



### 1. TECHNICAL SPECIFICATIONS

#### 1.1 FILTER HOUSING Construction

The filter housings are designed in accordance with international regulations. They consist of a filter head and a screw-in filter bowl. DFPF filters are suitable for flow in both directions.

Standard equipment:

- connection for a clogging indicator
- two-piece bowl for DFP/F 990 and above (optional for DFP/F 660 and above)
- without bypass valve
- drain screw with pressure relief (standard for DFP/F 330 and above)

#### 1.2 FILTER ELEMENTS

HYDAC filter elements are validated and their quality is constantly monitored according to the following standards:

- ISO 2941
- ISO 2942
- ISO 2943
- ISO 3724
- ISO 3968
- ISO 11170
- ISO 16889

Filter elements are available with the following pressure stability values:

Optimicon® (ON):	20 bar
Betamicon® (BH4HC):	210 bar
Wire mesh (W):	20 bar
Stainless steel fibre (V):	210 bar

#### 1.4 FILTER SPECIFICATIONS

Nominal pressure	315 bar *
Fatigue strength	At nominal pressure 10 <sup>6</sup> cycles (LC) from 0 to nominal pressure
Temperature range	-30 °C to +100 °C (-30 °C to -10 °C: p <sub>max</sub> = 157.5 bar)
Material of filter head	EN-GJS 400-15
Material of filter bowl	Steel
Type of clogging indicator up to	VD (differential pressure measurement 420 bar operating pressure)
Pressure setting of the clogging indicator	DFP = 5 bar DFPF = 8 bar (others on request)
Bypass cracking pressure (optional)	6 bar (others on request)

#### 1.4 SEALS

NBR (=Perbunan)

#### 1.5 INSTALLATION

Pressure filter for manifold block mounting, with or without reversible oil flow

#### 1.6 SPECIAL MODELS AND ACCESSORIES

- Bypass valve built into the head
- Seals in FPM, EPDM

#### 1.7 SPARE PARTS

See Original Spare Parts List

#### 1.8 CERTIFICATES AND APPROVALS on request

#### 1.9 COMPATIBILITY WITH HYDRAULIC FLUIDS ISO 2943

- Hydraulic oils H to HLPD DIN 51524
- Lubrication oils DIN 51517, API, ACEA, DIN 51515, ISO 6743
- Compressor oils DIN 51506
- Biodegradable operating fluids VDMA 24568 HETG, HEES, HEPG
- Fire-resistant fluids HFA, HFB, HFC and HFD
- Operating fluids with high water content (>50% water content) on request

#### 1.10 IMPORTANT INFORMATION

- Filter housings must be earthed.
- When using visual clogging indicators, the BM version (visual with manual reset) only should be used.
- When using electrical clogging indicators, the electrical power supply to the system must be switched off before removing the clogging indicator connector.

#### Symbol for hydraulic systems

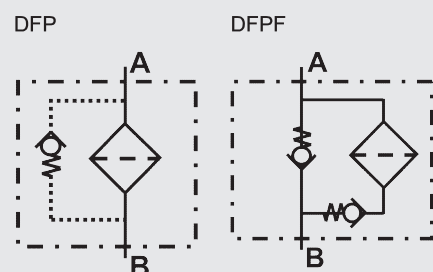

\*

Size 330 – 660		
	with bypass	without bypass
0–315 bar	95,000 LC	400,000 LC
0–350 bar	80,000 LC	350,000 LC

LC = load cycles

## 2. MODEL CODE (also order example)

DFP ON 60 Q B 10 D 1 . X /-L24

### 2.1 COMPLETE FILTER

#### Filter type

DFP or DFPF

#### Filter material

ON Optmicron®  
 BN/HC Betamicron® (BN4HC)  
 V Metal fibre  
 W Wire mesh

#### Size of filter or element

DFP/F: 60, 110, 140, 160, 240, 280, 330, 500, 660, 990, 1320

#### Operating pressure

Q = 315 bar

#### Type and size of connection

Type	Port	Filter size										
		60	110	140	160	240	280	330	500	660	990	1320
B	Ø 17,5	●	●	●								
C	Ø 21,4				●	●	●					
D	Ø 41							●	●	●	●	●

#### Filtration rating in µm

ON: 1, 3, 5, 10, 15, 20 BH/HC, V: 3, 5, 10, 20

W: 25, 50, 100, 200

#### Type of clogging indicator

Y plastic blanking plug in indicator port  
 A steel blanking plug in indicator port  
 BM visual  
 C electrical  
 D visual and electrical  
 for other clogging indicators, see brochure no. 7.050../..

#### Type code

1 one-piece filter bowl  
 2 two-piece filter bowl (DFP/F 660 to 1320)

#### Modification number

X the latest version is always supplied

#### Supplementary details

B. bypass cracking pressure (e.g. B6 = 6 bar); without details = without bypass valve  
 L... light with appropriate voltage (24, 48, 110, 220 volts)  
 LED 2 light-emitting diodes up to 24 volts  
 SO184 pressure release/oil drain screw (standard for size DFP/F 330 and above)  
 V FPM seals  
 W suitable for HFA and HFC emulsions

### 2.2 REPLACEMENT ELEMENT

0060 D 010 ON /-V

#### Size

0060, 0110, 0140, 0160, 0240, 0280, 0330, 0500, 0660, 0990, 1320

#### Type

D

#### Filtration range in µm

ON: 001, 003, 005, 010, 015, 020

BH4HC, V: 003, 005, 010, 020

W: 025, 050, 100, 200

#### Filter material

ON, BH4HC, V, W

#### Supplementary details

V, W (for descriptions, see point 2.1)

### 2.3 REPLACEMENT CLOGGING INDICATOR

VD 5 D . X /-L24

#### Type

VD differential pressure indicator up to 420 bar operating pressure

#### Pressure setting

5 standard for DFP filters 5 bar  
 8 standard for DFPF filters 8 bar } on request  
 others

#### Type of clogging indicator

D (see Point 2.1)

#### Modification number

X the latest version is always supplied

#### Supplementary details

L..., LED, V, W (for descriptions, see Point 2.1)

### 3. FILTER CALCULATION / SIZING

The total pressure drop of a filter at a certain flow rate Q is the sum of the housing  $\Delta p$  and the element  $\Delta p$  and is calculated as follows:

$$\Delta p_{\text{total}} = \Delta p_{\text{housing}} + \Delta p_{\text{element}}$$

$$\Delta p_{\text{housing}} = (\text{see Point 3.1})$$

$$\Delta p_{\text{element}} = Q \cdot \frac{SK^*}{1000} \cdot \frac{\text{viscosity}}{30}$$

(\*see Point 3.2)

For ease of calculation, our Filter Sizing Program is available on request free of charge.

**NEW:** Sizing online at [www.hydac.com](http://www.hydac.com)

### 3.1 $\Delta p$ -Q HOUSING CURVES BASED ON ISO 3968

The housing curves apply to mineral oil with a density of 0.86 kg/dm<sup>3</sup> and a kinematic viscosity of 30 mm<sup>2</sup>/s. In this case, the differential pressure changes proportionally to the density.

**DFP 60/110/140**

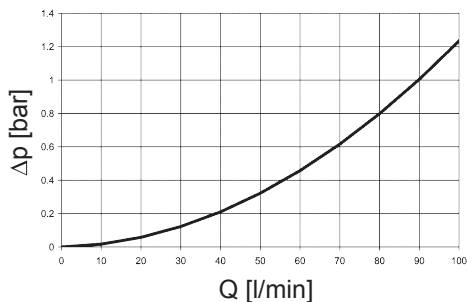

**DFP 160/240/280**

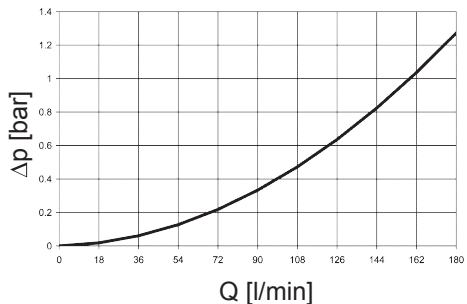

**DFP 330/500/660/990/1320**

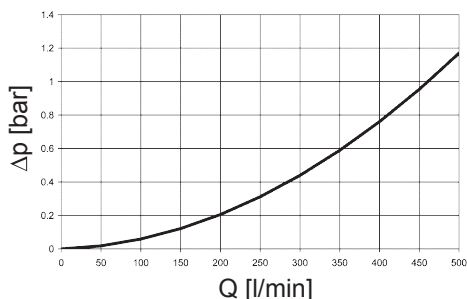

DFPF  $\Delta p$ -Q housing curves on request

### 3.2 GRADIENT COEFFICIENTS (SK) FOR FILTER ELEMENTS

The gradient coefficients in mbar/(l/min) apply to mineral oils with a kinematic viscosity of 30 mm<sup>2</sup>/s. The pressure drop changes proportionally to the change in viscosity.

DFP/ DFPF	ON					
	1 μm	3 μm	5 μm	10 μm	15 μm	20 μm
60	53.5	26.0	18.3	12.1	9.78	6.32
110	25.8	13.4	9.61	6.06	4.63	2.99
140	19.9	11.5	7.39	4.38	3.54	2.29
160	18.5	11.0	7.70	4.10	3.71	3.18
240	11.5	6.90	5.34	3.19	2.44	2.10
280	5.54	3.37	2.74	1.49	1.36	1.17
330	8.23	4.19	3.37	2.46	1.55	1.22
500	5.05	2.57	2.07	1.23	0.95	0.75
660	3.78	1.93	1.56	0.93	0.71	0.56
990	2.51	1.28	1.03	0.61	0.47	0.37
1320	1.85	0.97	0.76	0.45	0.35	0.27

DFP/ DFPF	V				W -	BH4HC			
	3 μm	5 μm	10 μm	20 μm		3 μm	5 μm	10 μm	20 μm
60	16.0	11.0	6.5	3.3	0.757	58.6	32.6	18.1	12.2
110	8.3	6.0	4.2	2.1	0.413	25.4	14.9	8.9	5.6
140	8.3	6.0	4.2	2.1	0.413	25.4	14.9	8.9	5.6
160	4.5	3.2	2.3	1.4	0.284	16.8	10.4	5.9	4.4
240	3.2	2.4	1.9	1.1	0.189	10.6	6.8	3.9	2.9
280	1.5	1.2	1.0	0.8	0.162	5.7	3.4	1.8	1.6
330	2.1	1.5	1.3	0.8	0.138	7.7	4.5	2.8	2.0
500	1.4	1.0	0.8	0.5	0.091	4.2	2.6	1.5	1.2
660	1.1	0.9	0.6	0.3	0.069	3.3	1.9	1.0	0.9
990	0.7	0.5	0.4	0.3	0.046	2.2	1.3	0.8	0.6
1320	0.6	0.5	0.3	0.2	0.035	1.6	1.0	0.6	0.4

## 4. DIMENSIONS: DFP

DFP 60 - 280

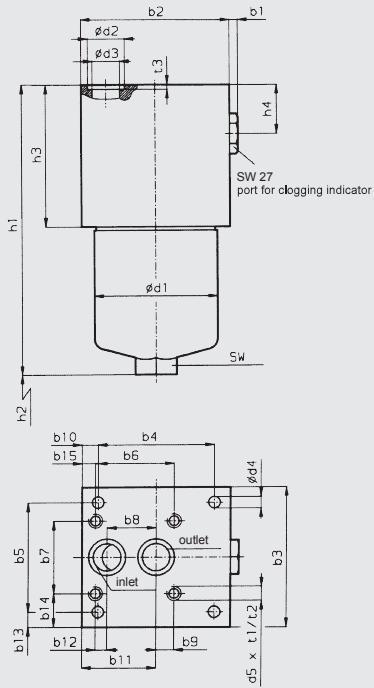

DFP 330 - 1320

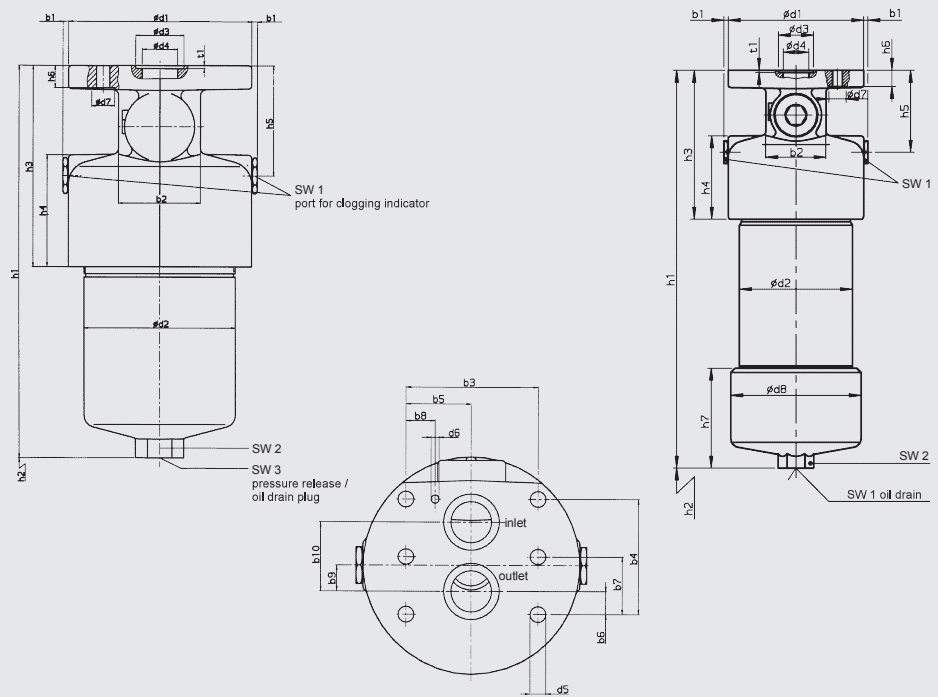

DFP	60	110	140	160	240	280	330	500	660..1.x	660..2.x	990..2.x	1320..2.x
b1	6	6	6	6	6	6	5	5	5	5	5	5
b2	104	104	104	115	115	115	70	70	70	70	70	70
b3	80	80	80	110	110	110	96.8	96.8	96.8	96.8	96.8	96.8
b4	89	89	89	90	90	90	84.1	84.1	84.1	84.1	84.1	84.1
b5	31.8	31.8	31.8	86	86	86	48.4	48.4	48.4	48.4	48.4	48.4
b6	-	-	-	61	61	61	16.7	16.7	16.7	16.7	16.7	16.7
b7	-	-	-	57	57	57	42.05	42.05	42.05	42.05	42.05	42.05
b8	31.6	31.6	31.6	38	38	38	21.4	21.4	21.4	21.4	21.4	21.4
b9	-	-	-	14	14	14	19	19	19	19	19	19
b10	7.5	7.5	7.5	12.5	12.5	12.5	50.7	50.7	50.7	50.7	50.7	50.7
b11	55.9	55.9	55.9	57.5	57.5	57.5	-	-	-	-	-	-
b12	-	-	-	9	9	9	-	-	-	-	-	-
b13	24.1	24.1	24.1	12	12	12	-	-	-	-	-	-
b14	-	-	-	26.5	26.5	26.5	-	-	-	-	-	-
b15	-	-	-	10.5	10.5	10.5	-	-	-	-	-	-
d1	68.2	68.2	68.2	95.2	95.2	95.2	158	158	158	158	158	158
d2	25.3	25.3	25.3	28.6	28.6	28.6	130	130	130	130	130	130
d3	17.5	17.5	17.5	21.4	21.4	21.4	41	41	41	41	41	41
d4	8.5	8.5	8.5	9	9	9	30	30	30	30	30	30
d5	-	-	-	7/16-14 UNC	7/16-14 UNC	7/16-14 UNC	11.5	11.5	11.5	11.5	11.5	11.5
d6	-	-	-	-	-	-	6	6	6	6	6	6
d7	-	-	-	-	-	-	20	20	20	20	20	20
d8	-	-	-	-	-	-	-	-	-	152	152	152
h1	158.5	227.5	269.5	199.5	263.5	445.0	339.5	432.5	510.0	504	660.0	826.0
h2	75	75	75	85	85	85	95	95	95	350	500	670
h3	76	76	76	83	83	83	174.5	174.5	174.5	174.5	174.5	174.5
h4	25	25	25	25	25	25	98	98	98	98	98	98
h5	-	-	-	-	-	-	96	96	96	96	96	96
h6	-	-	-	-	-	-	19	19	19	19	19	19
h7	-	-	-	-	-	-	-	-	-	112	112	112
t1	-	-	-	13	13	13	2.6	2.6	2.6	2.6	2.6	2.6
t2	-	-	-	18	18	18	-	-	-	-	-	-
t3	2	2	2	2	2	2	-	-	-	-	-	-
SW	27	27	27	32	32	32	-	-	-	-	-	-
SW1	-	-	-	-	-	-	27	27	27	27	27	27
SW2	-	-	-	-	-	-	36	36	36	36	36	36
SW 3	-	-	-	-	-	-	10	10	10	10	10	10
Weight incl. element [kg]	5.1	6.0	6.6	9.1	10.4	14.7	21.0	25.5	29.0	32.0	39.2	47.1
Volume of pressure chamber [l]	0.20	0.33	0.40	0.60	0.80	1.60	1.50	2.30	3.00	3.00	4.20	5.60

# DFPF

## DFPF 60 - 280

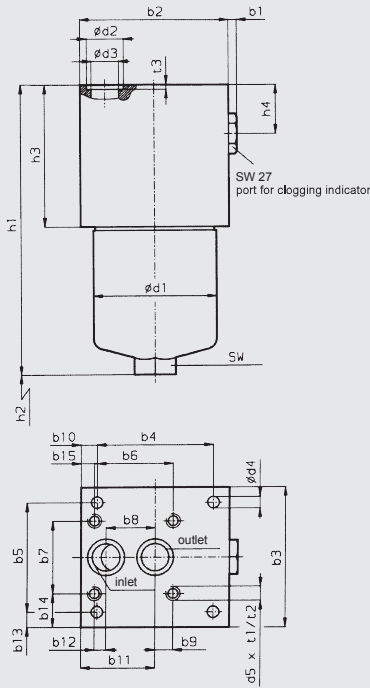

## DFPF 330 - 1320

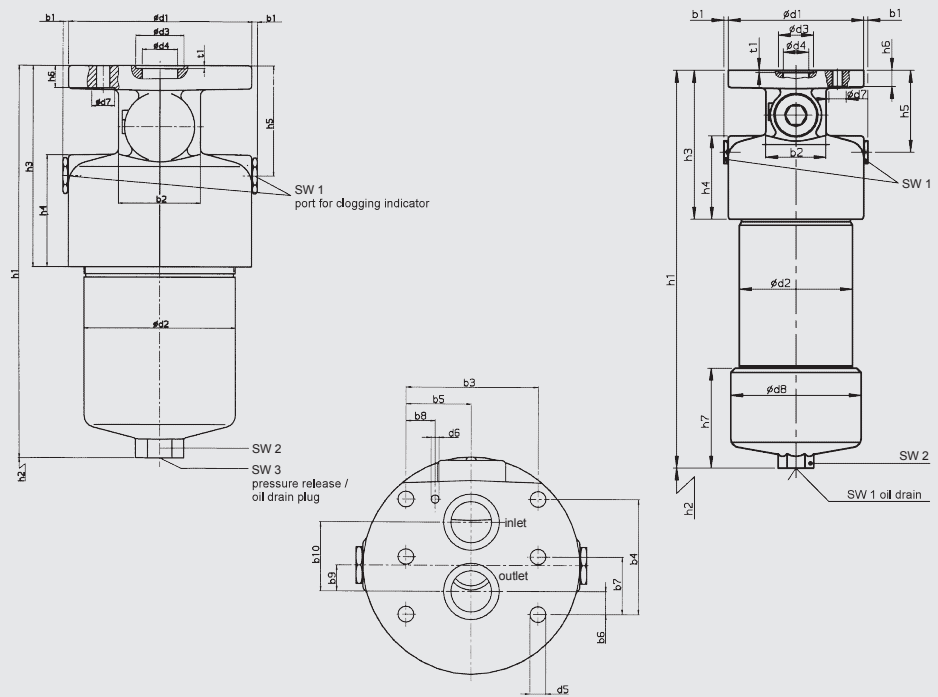

DFPF	60	110	140	160	240	280	330	500	660..1.x	660..2.x	990..2.x	1320..2.x
b1	6	6	6	6	6	6	5	5	5	5	5	5
b2	104	104	104	120	120	120	70	70	70	70	70	70
b3	80	80	80	110	110	110	96.8	96.8	96.8	96.8	96.8	96.8
b4	89	89	89	90	90	90	84.1	84.1	84.1	84.1	84.1	84.1
b5	31.8	31.8	31.8	86	86	86	48.4	48.4	48.4	48.4	48.4	48.4
b6	-	-	-	61	61	61	16.7	16.7	16.7	16.7	16.7	16.7
b7	-	-	-	57	57	57	42.05	42.05	42.05	42.05	42.05	42.05
b8	31.6	31.6	31.6	38	38	38	21.4	21.4	21.4	21.4	21.4	21.4
b9	-	-	-	14	14	14	19	19	19	19	19	19
b10	7.5	7.5	7.5	17.5	17.5	17.5	50.7	50.7	50.7	50.7	50.7	50.7
b11	55.9	55.9	55.9	62.5	62.5	62.5	-	-	-	-	-	-
b12	-	-	-	9	9	9	-	-	-	-	-	-
b13	24.1	24.1	24.1	12	12	12	-	-	-	-	-	-
b14	-	-	-	26.5	26.5	26.5	-	-	-	-	-	-
b15	-	-	-	15.5	15.5	15.5	-	-	-	-	-	-
d1	68.2	68.2	68.2	95.2	95.2	158	158	158	158	158	158	158
d2	25.3	25.3	25.3	28.6	28.6	28.6	130	130	130	130	130	130
d3	17.5	17.5	17.5	21.4	21.4	21.4	41	41	41	41	41	41
d4	8.5	8.5	8.5	9	9	9	30	30	30	30	30	30
d5	-	-	-	7/8-14 UNC	7/8-14 UNC	7/8-14 UNC	11.5	11.5	11.5	11.5	11.5	11.5
d6	-	-	-	-	-	-	6	6	6	6	6	6
d7	-	-	-	-	-	-	20	20	20	20	20	20
d8	-	-	-	-	-	-	-	-	-	152	152	152
h1	158.5	227.5	269.5	206.5	266.5	448.5	339.5	432.5	510.0	504	660.0	826.0
h2	75	75	75	85	85	85	95	95	95	350	500	670
h3	76	76	76	90	90	90	174.5	174.5	174.5	174.5	174.5	174.5
h4	21	21	21	32	32	32	98	98	98	98	98	98
h5	-	-	-	-	-	-	96	96	96	96	96	96
h6	-	-	-	-	-	-	19	19	19	19	19	19
h7	-	-	-	-	-	-	-	-	-	112	112	112
t1	-	-	-	13	13	13	2.6	2.6	2.6	2.6	2.6	2.6
t2	-	-	-	18	18	18	-	-	-	-	-	-
t3	2	2	2	2	2	2	-	-	-	-	-	-
SW	27	27	27	32	32	32	-	-	-	-	-	-
SW1	-	-	-	-	-	-	27	27	27	27	27	27
SW2	-	-	-	-	-	-	36	36	36	36	36	36
SW 3	-	-	-	-	-	-	10	10	10	10	10	10
Weight incl. element [kg]	5.1	6.0	6.6	9.1	10.4	14.7	21.0	25.5	29.0	32.0	39.2	47.1
Volume of pressure chamber [l]	0.20	0.33	0.40	0.60	0.80	1.60	1.50	2.30	3.00	3.00	4.20	5.60

