

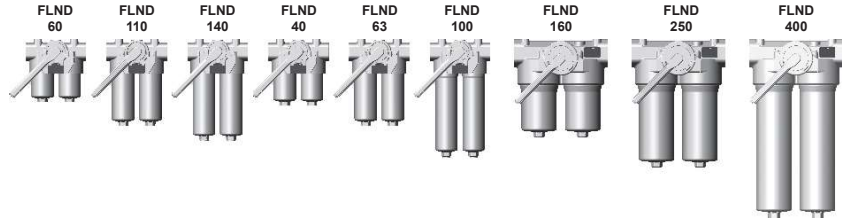

## Change-Over Inline Filter FLND

to DIN 24550\*, up to 400 l/min, up to 63 bar  
\*Filters and filter elements also available in HYDAC dimensions



### 1. TECHNICAL SPECIFICATIONS

#### 1.1 FILTER HOUSING

##### Construction

The filter housings are designed in accordance with international regulations. They consist of a filter head with built-in change-over valve and screw-in filter bowls.

Standard equipment:

- without bypass valve
- connection for a clogging indicator
- oil drain plug (FLND 160 to 400)

#### 1.2 FILTER ELEMENTS

HYDAC filter elements are validated and their quality is constantly monitored according to the following standards:

- ISO 2941, ISO 2942, ISO 2943, ISO 3724, ISO 3968, ISO 11170, ISO 16889

Filter elements are available with the following pressure stability values:

|                                     |         |
|-------------------------------------|---------|
| Optimicon® (ON) <sup>1)</sup> :     | 20 bar  |
| Betamicon® (BN4HC) <sup>2)</sup> :  | 20 bar  |
| Betamicon® (BH4HC):                 | 210 bar |
| Wire mesh (W/HC, W) <sup>3)</sup> : | 20 bar  |

<sup>1)</sup> only for FLND 60, 110, 140

<sup>2)</sup> only for FLND 40, 63, 100, 160, 250, 400

<sup>3)</sup> only for FLND 40–140

### 1.3 FILTER SPECIFICATIONS

|  |   |
|--|---|
| Nominal pressure                           | 25 bar (FLND 160 to 400)<br>63 bar (FLND 40 to 140)                     |
| Fatigue strength                           | At nominal pressure 10 <sup>6</sup> cycles from 0 to nominal pressure   |
| Temperature range                          | -10 °C to +100 °C   |
| Material of filter head                    | Aluminium   |
| Material of filter bowl                    | Aluminium (FLND 100 and 140: Steel)                                     |
| Type of clogging indicator                 | VM (differential pressure measurement up to 210 bar operating pressure) |
| Pressure setting of the clogging indicator | 2.5 bar or 5 bar (others on request)                                    |
| Bypass cracking pressure (optional)        | 3.5 bar or 7 bar (others on request)                                    |

### 1.4 SEALS

NBR (=Perbunan)

### 1.5 INSTALLATION

Inline filter

### 1.6 SPECIAL MODELS AND ACCESSORIES

- With bypass valve
- With oil drain plug for FLND 40 to 140 (SO184)
- Seals in FPM, EPDM
- Reverse flow "RL" for FLND 160 and above on request

### 1.7 SPARE PARTS

See Original Spare Parts List

### 1.8 CERTIFICATES AND APPROVALS

These filters can be supplied with manufacturer's test certificates O and M to DIN 55350, Part 18.

Test certificates 3.1 to DIN EN 10204 and approval certificates (Type Approval) for different approval authorities.

### 1.9 COMPATIBILITY WITH HYDRAULIC FLUIDS ISO 2943

- Hydraulic oils H to HLPD DIN 51524
- Lubrication oils DIN 51517, API, ACEA, DIN 51515, ISO 6743
- Compressor oils DIN 51506
- Biodegradable operating fluids VDMA 24568 HETG, HEES, HEPG
- Fire-resistant fluids HFA, HFB, HFC and HFD
- Operating fluids with high water content (>50% water content) on request

### 1.10 IMPORTANT INFORMATION

- Filter housings must be earthed.
- When using electrical clogging indicators, the electrical power supply to the system must be switched off before removing the clogging indicator connector.
- Filters with switching valve are designed to have a permissible leakage depending on the operating medium.

### Symbol for hydraulic systems

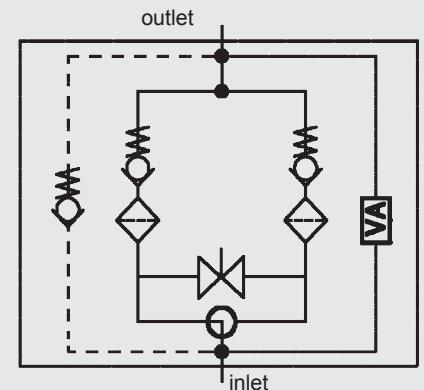

VA = clogging indicator

## 2. MODEL CODE (also order example)

FLND BN/HC 250 D D F 10 D 1 . X /-L24

### 2.1 COMPLETE FILTER

#### Filter type

FLND

#### Filter material

ON Optimicron® (BG 60, 110, 140 only) BN/HC Betamicon® (BN4HC) (BG 40, 63, 100, 160, 250, 400 only)  
 BH/HC Betamicon® (BH4HC) W/HC, W\* Wire mesh

#### Size of filter or element

FLND: 40, 60, 63, 100, 110, 140, 160, 250, 400

#### Operating pressure

D = 25 bar (FLND 160 to 400)  
 F = 63 bar (FLND 40 to 140)

#### Type of change-over

D single switching valve and check valve

#### Type and size of port

to DIN 24550 (●), possible ports (X)

| Type | Port    | Filter size ... not to DIN 24550 |     |     | ... to DIN 24550 |    |     |     |     |     |
|------|---------|----------------------------------|-----|-----|------------------|----|-----|-----|-----|-----|
|      |         | 60                               | 110 | 140 | 40               | 63 | 100 | 160 | 250 | 400 |
| B    | G 1/2   | X                                | X   | X   | ●                | X  | X   |     |     |     |
| C    | G 3/4   | X                                | X   | X   | X                | ●  | X   |     |     |     |
| D    | G 1     | X                                | X   | X   | X                | X  | ●   |     |     |     |
| E    | G 1 1/4 |                                  |     |     |                  |    |     | ●   | X   | X   |
| F    | G 1 1/2 |                                  |     |     |                  |    |     | X   | ●   | X   |
| I    | DN 25** | X                                | X   | X   | X                | X  | X   |     |     |     |
| K    | DN 38** |                                  |     |     |                  |    |     | X   | X   | ●   |

\*\* Flange SAE, 3000 PSI

#### Filtration rating in µm

ON: 1, 3, 5, 10, 15, 20 BH/HC: 3, 5, 10, 20  
 BN/HC, BH/HC to DIN 24550: 3, 6, 10, 25 W/HC, W\*: 25, 50, 100, 200

#### Type of clogging indicator

Y plastic blanking plug in indicator port  
 A steel blanking plug in indicator port  
 B visual  
 C electrical  
 D visual and electrical  
 LZ visual-mechanical / electrical  
 for other clogging indicators, see brochure no. 7.050.../..

#### Type code

1

#### Modification number

X the latest version is always supplied

#### Supplementary details

B. bypass cracking pressure (e.g. B3.5 = 3.5 bar); without details = without bypass valve  
 L... light with appropriate voltage (24V, 48V, 110V, 220V) only for clogging indicators type D  
 LED 2 light emitting diodes up to 24 Volt  
 AV LZ indicator with plug to AUDI and VW specification  
 BO LZ indicator with plug and pin connections to BMW and Opel specification (M12x1)  
 CN LZ indicator with plug to DIN 43651 with 3 LEDs (CNOMO specification)  
 DB LZ indicator with plug to DIN 43651 with 3 LEDs (Daimler-Benz specification)  
 D4C LZ with plug and connector to Daimler-Chrysler specification and cold start suppression 30°C  
 BO-LED as for BO, but with diode strip  
 SO184 oil drain plug (FLND 40 to 140)  
 V FPM seals  
 W suitable for HFA and HFC emulsions

### 2.2 REPLACEMENT ELEMENT

0250 DN 010 BN4HC /-V

#### Size

0040, 0060, 0063, 0100, 0110, 0140, 0160, 0250, 0400

#### Type

D 0060, 0110, 0140  
 DN to DIN 24550: 0040, 0063, 0100, 0160, 0250, 0400

#### Filtration rating in µm

ON 001, 003, 005, 010, 015, 020 BH4HC: 003, 005, 010, 020  
 BN4HC, BH4HC to DIN 24550: 003, 006, 010, 025 W/HC, W\*: 025, 050, 100, 200

#### Filter material

ON, BN4HC, BH4HC, W/HC, W\*

#### Supplementary details

V, W (for descriptions, see Point 2.1)

### 2.3 REPLACEMENT CLOGGING INDICATOR

VM 5 D . X /-L24

#### Type

VM differential pressure measurement up to 210 bar operating pressure

#### Pressure setting

5 standard 5 bar, others on request

#### Type of clogging indicator (see Point 2.1)

#### Modification number

X the latest version is always supplied

#### Supplementary details

L..., LED, V, W, AV, BO, CN, DB, D4C, BO-LED (for descriptions see Point 2.1)

\* only for FLND 40 - 140

### 3. FILTER CALCULATION / SIZING

The total pressure drop of a filter at a certain flow rate Q is the sum of the housing  $\Delta p$  and the element  $\Delta p$  and is calculated as follows:

$$\Delta p_{\text{total}} = \Delta p_{\text{housing}} + \Delta p_{\text{element}}$$

$$\Delta p_{\text{housing}} = (\text{see Point 3.1})$$

$$\Delta p_{\text{element}} = Q \cdot \frac{SK^*}{1000} \cdot \frac{\text{viscosity}}{30}$$

(\*see Point 3.2)

For ease of calculation, our Filter Sizing Program is available on request free of charge.

**NEW:** Sizing online at [www.hydac.com](http://www.hydac.com)

#### 3.1 $\Delta p$ -Q HOUSING CURVES BASED ON ISO 3968

The housing curves apply to mineral oil with a density of 0.86 kg/dm<sup>3</sup> and a kinematic viscosity of 30 mm<sup>2</sup>/s. In this case, the differential pressure changes proportionally to the density.

##### FLND 40, 60, 63, 100, 110, 140

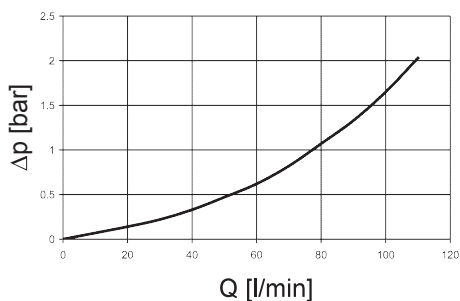

##### FLND 160, 250, 400

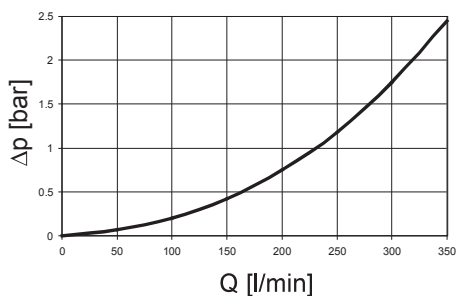

### 3.2 GRADIENT COEFFICIENTS (SK) FOR FILTER ELEMENTS

The gradient coefficients in mbar/(l/min) apply to mineral oils with a kinematic viscosity of 30 mm<sup>2</sup>/s. The pressure drop changes proportionally to the change in viscosity.

| FLND | ... D ... ON |      |      |       |       |       |
|------|--------------|------|------|-------|-------|-------|
|      | 1 μm         | 3 μm | 5 μm | 10 μm | 15 μm | 20 μm |
| 60   | 53.5         | 26.0 | 18.3 | 12.1  | 9.78  | 6.32  |
| 110  | 25.8         | 13.4 | 9.61 | 6.06  | 4.63  | 2.99  |
| 140  | 19.9         | 11.5 | 7.39 | 4.38  | 3.54  | 2.29  |

| FLND | ... DN ... BN4HC |      |       |       |
|------|------------------|------|-------|-------|
|      | 3 μm             | 6 μm | 10 μm | 25 μm |
| 40   | 40.4             | 24.8 | 16.4  | 10.9  |
| 63   | 29.0             | 18.2 | 11.7  | 7.6   |
| 100  | 19.0             | 11.7 | 7.7   | 5.3   |
| 160  | 8.0              | 5.1  | 3.8   | 2.5   |
| 250  | 5.4              | 3.4  | 2.8   | 1.9   |
| 400  | 3.4              | 2.1  | 1.7   | 1.1   |

| FLND | ... D ... BH4HC |      |       |       | W/HC-W | ... DN ... BH4HC |      |       |       |
|------|-----------------|------|-------|-------|--------|------------------|------|-------|-------|
|      | 3 μm            | 5 μm | 10 μm | 20 μm |        | 3 μm             | 6 μm | 10 μm | 25 μm |
| 60   | 58.6            | 32.6 | 18.1  | 12.2  | 0.757  | -                | -    | -     | -     |
| 110  | 25.4            | 14.9 | 8.9   | 5.6   | 0.413  | -                | -    | -     | -     |
| 140  | 19.9            | 11.3 | 8.1   | 4.3   | 0.324  | -                | -    | -     | -     |
| 40   | -               | -    | -     | -     | 0.966  | 40.4             | 24.8 | 16.4  | 10.9  |
| 63   | -               | -    | -     | -     | 0.540  | 29.0             | 18.2 | 11.7  | 7.6   |
| 100  | -               | -    | -     | -     | 0.325  | 19.0             | 11.7 | 7.7   | 5.3   |
| 160  | -               | -    | -     | -     | 0.168  | 8.0              | 5.1  | 3.8   | 2.5   |
| 250  | -               | -    | -     | -     | 0.101  | 5.4              | 3.4  | 2.8   | 1.9   |
| 400  | -               | -    | -     | -     | 0.068  | 3.4              | 2.1  | 1.7   | 1.1   |

