

Pressure Filter HFM up to 140 l/min, up to 400 bar



1. TECHNICAL SPECIFICATIONS

1.1 FILTER HOUSING

Construction

The filter housings are designed in accordance with international regulations. They consist of a filter head and a screw-in filter bowl.

Standard equipment:

- bypass valve
- connection for a clogging indicator on the top of the head (4 mounting holes)

1.2 FILTER ELEMENTS

HYDAC filter elements are validated and their quality is constantly monitored according to the following standards:

- ISO 2941
- ISO 2942
- ISO 2943
- ISO 3724
- ISO 3968
- ISO 11170
- ISO 16889

Filter elements are available with the following pressure stability values:
Optimicron® (ON): 20 bar

1.3 FILTER SPECIFICATIONS

Nominal pressure	400 bar
Fatigue strength	At nominal pressure 10 ⁶ cycles from 0 to nominal pressure
Temperature range	-10 °C to +100 °C (-30 °C to -10 °C: p _{max} = 200 bar)
Material of filter head	EN-GJS 400-15
Material of filter bowl	Cold extruded steel
Type of clogging indicator	VD (differential pressure measurement up to 420 bar operating pressure)
Pressure setting of the clogging indicator	5 bar (others on request)
Bypass cracking pressure	7 bar (others on request)

1.4 SEALS

NBR (=Perbunan)

1.5 INSTALLATION

INLINE FILTER

1.6 SPECIAL MODELS AND ACCESSORIES

On request

1.7 SPARE PARTS

See Original Spare Parts List

1.8 CERTIFICATES AND APPROVALS

On request

1.9 COMPATIBILITY WITH HYDRAULIC FLUIDS ISO 2943

- Hydraulic oils H to HLPD DIN 51524
- Lubrication oils DIN 51517, API, ACEA, DIN 51515, ISO 6743
- Compressor oils DIN 51506
- Biodegradable operating fluids VDMA 24568 HETG, HEES, HEPG
- Operating fluids with high water content (>50% water content) on request

1.10 MAINTENANCE INSTRUCTIONS

- Filter housings must be earthed.
- When using electrical clogging indicators, the electrical power supply to the system must be switched off before removing the clogging indicator connector.

Symbol for hydraulic systems

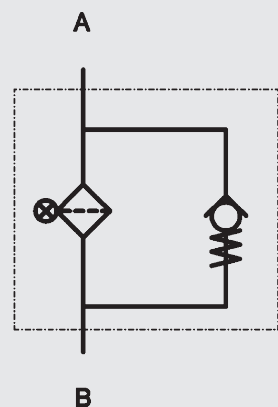

2. MODEL CODE (also order example)

HFM ON 75 S J 10 D 1 . X /-L24

2.1 COMPLETE FILTER

Filter type

HFM

Filter material

ON Optimicron®

Size of filter or element

HFM: 75, 95

Operating pressure

S = 400 bar

Type and size of connection

Type	Port	Filter size	
		75	95
H	G ¾	●	●
J	G 1	●	●

Filtration rating in µm

ON: 1, 3, 5, 10, 15, 20

Type of clogging indicator

W without port (no clogging indicator)
A screw plug in indicator port
B visual
C electrical
D visual and electrical] for other clogging indicators,
see brochure no. 7.050../..

Type code

1

Modification number

X the latest version is always supplied

Supplementary details

B7 standard: bypass cracking pressure 7 bar
L... light with appropriate voltage (24, 48, 110, 220 volts)] only for clogging indicator
LED 2 light-emitting diodes up to 24 volts] indicators type "D"
V FPM seals
W suitable for HFA and HFC emulsions

2.2 REPLACEMENT ELEMENT

0075 D 010 ON /-V

Size

0075, 0095

Type

D

Filtration rating in µm

ON: 001, 003, 005, 010, 015, 020

Filter material

ON

Supplementary details

V (for descriptions, see Point 2.1)

2.3 REPLACEMENT CLOGGING INDICATOR

VD 5 D . X /-L24

Type of indicator

VD differential pressure indicator up to 420 bar operating pressure

Pressure setting

5 standard 5 bar, others on request

Type of clogging indicator

D (see Point 2.1)

Modification number

X the latest version is always supplied

Supplementary details

L..., LED, V, W (for descriptions, see Point 2.1)

3. FILTER CALCULATION / SIZING

The total pressure drop of a filter at a certain flow rate Q is the sum of the housing Δp and the element Δp and is calculated as follows:

$$\Delta p_{\text{total}} = \Delta p_{\text{housing}} + \Delta p_{\text{element}}$$

$$\Delta p_{\text{housing}} = (\text{see Point 3.1})$$

$$\Delta p_{\text{element}} = Q \cdot \frac{SK^*}{1000} \cdot \frac{\text{viscosity}}{30}$$

(*see Point 3.2)

For ease of calculation, our Filter Sizing Program is available on request free of charge.

NEW: Sizing online at www.hydac.com

3.1 Δp -Q HOUSING CURVES BASED ON ISO 3968

The housing curves apply to mineral oil with a density of 0.86 kg/dm³ and a kinematic viscosity of 30 mm²/s. In this case, the differential pressure changes proportionally to the density.

HFM

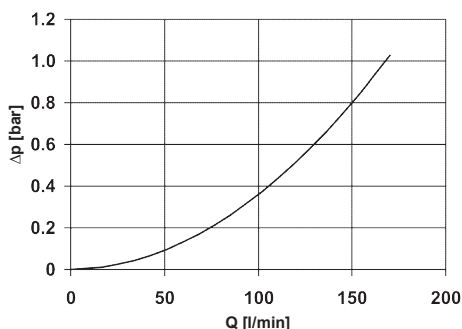

3.2 GRADIENT COEFFICIENTS (SK) FOR FILTER ELEMENTS

The gradient coefficients in mbar/(l/min) apply to mineral oils with a kinematic viscosity of 30 mm²/s. The pressure drop changes proportionally to the change in viscosity.

HFM	ON					
	1 μm	3 μm	5 μm	10 μm	15 μm	20 μm
75	16.7	8.40	6.75	5.40	3.33	2.48
95	13.2	6.74	5.40	4.33	2.62	1.92

4. DIMENSIONS

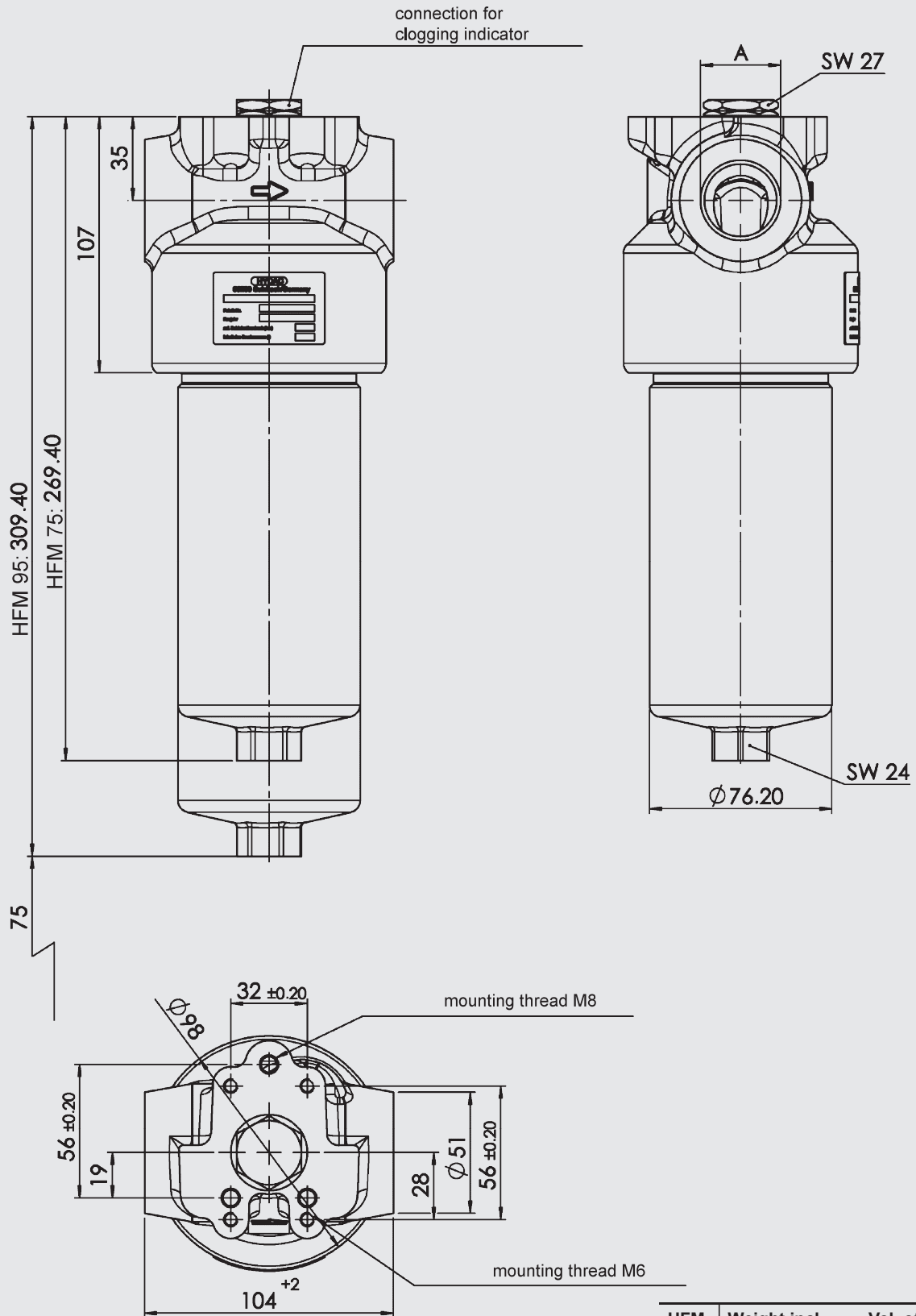

HFM	Weight incl. element [kg]	Vol. of pressure chamber [l]
75	5.6	0.56
95	6.1	0.69

NOTE

The information in this brochure relates to the operating conditions and applications described.
For applications or operating conditions not described, please contact the relevant technical department.
Subject to technical modifications.

HYDAC Filtrertechnik GmbH
Industriegebiet
D-66280 Sulzbach/Saar
Tel.: 0 68 97 / 509-01
Fax: 0 68 97 / 509-300
Internet: www.hydac.com
E-Mail: filter@hydac.com