



## Bladder accumulators Standard design

### 1. DESCRIPTION

#### 1.1. FUNCTION

While fluids are practically incompressible, this does not apply to gases. Hydraulic accumulators use these basic laws of physics to store hydraulic energy. Nitrogen is normally used as the compressible medium.

The various types of hydraulic accumulator are categorised on the basis of the separation element that keeps the gas section separate from the fluid section in the pressure vessel. In the case of a bladder accumulator, the separation element is a closed elastomer bladder.

The fluid side of the bladder accumulator is connected to the hydraulic circuit so that the bladder accumulator draws in fluid when the system pressure increases and the trapped gas is compressed.

When the system pressure drops, the compressed gas expands and forces the stored fluid back out into the hydraulic circuit.

HYDAC bladder accumulators are available in various designs – see catalogue sections:

- Bladder accumulators Low pressure  
No. 3.202



- Bladder accumulators High pressure  
No. 3.203



Bladder accumulators can also be used as dampers, for example - see catalogue section:

- Hydraulic dampers  
No. 3.701



## 1.2. DESIGN

### ■ SB330/400/500/550

HYDAC standard bladder accumulators consist of the pressure vessel, the flexible bladder with gas valve and the hydraulic connection with check valve. The pressure vessels are seamless and manufactured from high-tensile steel.

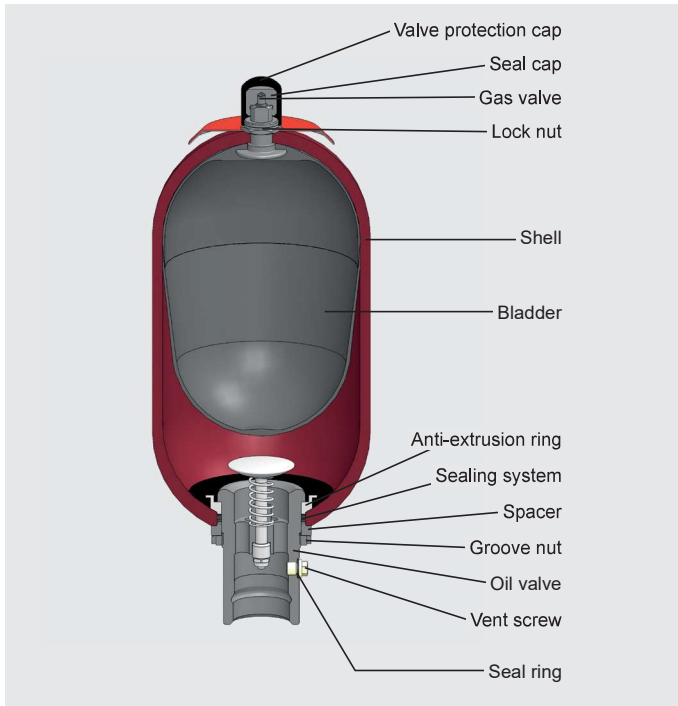

### ■ SB330N

The flow-optimised design of the standard oil valve enables the maximum possible operating fluid flow rate to increase to 25 l/s with this accumulator type.

### ■ SB330H (High Flow)

HYDAC high flow bladder accumulators type SB330 are high performance accumulators with a flow rate of up to 30 l/s. The fluid port is enlarged to allow higher flow rates.

### ■ SB600

For higher pressures, with the ASME U Stamp, HYDAC provides the series SB600 with approval S ( $p_{max}$  345 bar / 5000 psi).

### ■ Bladder accumulator SB330B

HYDAC bladder accumulators SB330B are designed to allow the bladder to be removed from above (top repairable). This has the advantage that the bladder accumulator does not need to be removed from the hydraulic system for inspection and repair work.



### ■ Bladder accumulator back-up version

To extend the gas volume of a hydraulic accumulator, HYDAC supplies back-up versions (version 1 in this case).

For more information, see catalogue section:

- Hydraulic accumulators with back-up nitrogen bottles No. 3.553

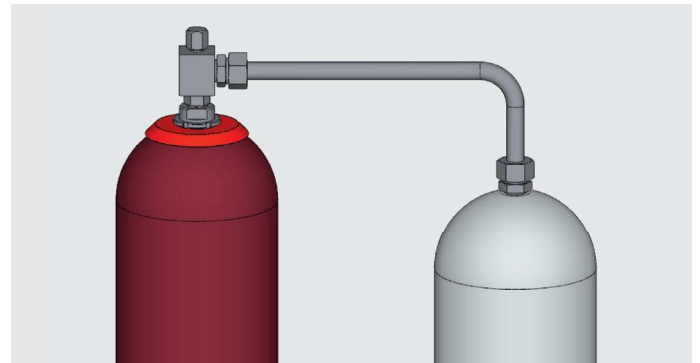

## 2. GENERAL INFORMATION

### 2.1. MATERIALS, CORROSION PROTECTION

#### 2.1.1 Accumulator shell

The accumulator shells are made from carbon steel as standard.

For operation with chemically aggressive media, the accumulator shell can be supplied with corrosion protection (such as chemical nickel-plating). If this is insufficient, then stainless steel hydraulic accumulators must be used.

#### 2.1.2 Bladder

The bladder material must be selected in accordance with the particular operating medium or operating temperature, see section 2.1.3. If discharge conditions are unfavourable (high  $p_2/p_0$  pressure ratio, rapid discharge speed), the gas may cool to below the permitted temperature. This can cause cold cracking. The gas temperature can be calculated using the HYDAC Accumulator Simulation Program **ASP**.

#### 2.1.3 Maximum temperature range of elastomer materials

The permitted working temperature of a bladder accumulator is dependent on the applications limits of the metal materials and the bladder. The operating medium must also be taken into account.

The following table shows the main **elastomer materials with their maximum possible temperature ranges** with examples of operating fluids.

Materials		Material code <sup>1)</sup>	Max. possible temperature range <sup>2)</sup>	Possible operating fluids, others on request	
				Resistant to	Not resistant to
NBR	Acrylonitrile butadiene rubber	2	-15 °C ... + 80 °C	<ul style="list-style-type: none"> <li>- Mineral oil (HL, HLP)</li> <li>- Flame-retardant fluids from the groups HFA, HFB, HFC</li> <li>- Synthetic esters (HEES)</li> <li>- Water</li> <li>- Sea water</li> </ul>	<ul style="list-style-type: none"> <li>- Aromatic hydrocarbons</li> <li>- Chlorinated hydrocarbons (HFD-S)</li> <li>- Amines and ketones</li> <li>- Hydraulic fluids from the group HFD-R</li> <li>- Fuels</li> </ul>
		5	-50 °C ... + 50 °C		
		9	-30 °C ... + 80 °C		
ECO	Ethylene oxide epichlorohydrin rubber	3	-30 °C ... +120 °C	<ul style="list-style-type: none"> <li>- Mineral oil (HL, HLP)</li> <li>- Flame-retardant fluids from the HFB group</li> <li>- Synthetic esters (HEES)</li> <li>- Water</li> <li>- Sea water</li> </ul>	<ul style="list-style-type: none"> <li>- Aromatic hydrocarbons</li> <li>- Chlorinated hydrocarbons (HFD-S)</li> <li>- Amines and ketones</li> <li>- Hydraulic fluids from the group HFD-R</li> <li>- Flame-retardant fluids from the groups HFA and HFC</li> <li>- Fuels</li> </ul>
IIR	Butyl rubber	4	-50 °C ... +100 °C	<ul style="list-style-type: none"> <li>- Hydraulic fluids from the group HFD-R</li> <li>- Flame-retardant fluids from the group HFC</li> <li>- Water</li> </ul>	<ul style="list-style-type: none"> <li>- Mineral oils and mineral greases</li> <li>- Synthetic esters (HEES)</li> <li>- Aliphatic, chlorinated and aromatic hydrocarbons</li> <li>- Fuels</li> </ul>
FKM	Fluorine rubber	6	-10 °C ... +150 °C	<ul style="list-style-type: none"> <li>- Mineral oil (HL, HLP)</li> <li>- Hydraulic fluids from the group HFD</li> <li>- Synthetic esters (HEES)</li> <li>- Fuels</li> <li>- Aromatic hydrocarbons</li> <li>- Inorganic acids</li> </ul>	<ul style="list-style-type: none"> <li>- Amines and ketones</li> <li>- Ammonia</li> <li>- Skydrol and HyJet IV</li> <li>- Steam</li> </ul>

<sup>1)</sup> The material code (MC) is described in more detail in the model code, see section 3.

<sup>2)</sup> The specified temperature range relates to the particular elastomer material, not to the operating range of the hydraulic accumulator, see section 4.1.1

## 2.2. INSTALLATION POSITION

HYDAC bladder accumulators can be installed vertically, horizontally and at a slant. When installing vertically or at a slant, the oil valve must be at the bottom.

For certain applications listed below, particular positions are preferable:

- Energy storage: vertical
- Pulsation damping: any position from horizontal to vertical
- Maintaining constant pressure: any position from horizontal to vertical
- Volume compensation: vertical

If the installation position is horizontal or at a slant, the effective fluid volume and the maximum permitted flow rate of the operating fluid are reduced.

## 2.3. TYPE OF INSTALLATION

By using an adapter, HYDAC hydraulic accumulators with a volume of up to 1 l can be installed directly inline.

For strong vibrations and volumes above 1 litre, we recommend HYDAC mounting elements – see catalogue section:

- Mounting elements for hydraulic accumulators  
No. 3.502
- ACCUSET SB  
No. 3.503

## 2.4. CHARGING GAS

- Charging gas: Nitrogen
- Specification: min. Class 2.8

If other gases are to be used or if these specifications are deviated from, please contact HYDAC.

## 2.5. CERTIFICATES

Hydraulic accumulators that are installed outside of Germany are supplied with the relevant test certificate documentation. The country of installation must be stated at the time of ordering. HYDAC pressure vessels can be supplied with almost any approval classification. The permitted operating pressure may differ from the nominal pressure.

The following table provides some examples of the code in the model code:

Country	Certificate code (CC)
EU member states	U
Australia	F <sup>1)</sup>
Belarus	A6
Canada	S1 <sup>1)</sup>
China	A9
Great Britain	Y
Hong Kong	A9
Iceland	U
Japan	P
Korea (Republic of)	A11
New Zealand	T
Norway	U
Russia	A6
South Africa	S2
Switzerland	U
Turkey	U
Ukraine	A10
USA	S

<sup>1)</sup> Registration required in the individual territories or provinces.

Others on request

## 2.6. FURTHER INFORMATION

- Operating instructions for bladder accumulators  
No. 3.201.BA

### **The operating instructions must be observed!**

All work on HYDAC bladder accumulators must only be carried out by suitably trained staff. Incorrect installation or handling can lead to serious accidents.

- Assembly and repair instructions bladder accumulators  
No. 3.201.M

For repairs to be performed on hydraulic accumulators, we provide corresponding assembly and repair instructions.

Further information such as accumulator sizing, safety information and extracts from the acceptance specifications can be found in our overview catalogue section:

- HYDAC Accumulator Technology  
No. 3.000

This document and others are available from our Download Center at [www.hydac.com](http://www.hydac.com).

### 3. MODEL CODE

Not all combinations are possible. Order example.  
For further information, please contact HYDAC.

SB330 (H) - 32 A 1 / 112 U - 330 A 050

#### Series

#### Type code

No details = standard

- H = high flow
- N = flow-optimised valve, fluid side
- A = shock absorber <sup>1)</sup>
- P = pulsation damper <sup>2)</sup>
- B = bladder top-repairable
- E = bladder with foam filling
- DA = bladder integrity system, industry version (others on request)
- L = light-weight

Combinations must be agreed with HYDAC.

#### Nominal volume [l]

#### Fluid port

- A = standard connection, thread with internal seal face
- F = flange connection
- C = valve mounting with screws on underside
- E = sealing surfaces on front interface (e.g. for thread M50x1.5 – valve)
- G = external thread
- S = special connection, to customer specification

#### Gas side connection

- 1 = standard design (see section 4.1.8)
- 2 = back-up version<sup>3)</sup>
- 3 = gas valve 7/8-14UNF with M8 internal thread
- 4 = gas valve 7/8-14UNF with gas valve connection 5/8-18UNF
- 5 = gas valve M50x1.5 in accumulators smaller than 50 l
- 6 = 7/8-14UNF gas valve
- 7 = M28x1.5 gas valve
- 8 = M16x1.5 gas valve (with M14x1.5 bore in gas valve)
- 9 = special gas valve, to customer specification

#### Material code (MC)

Dependent on operating medium  
Standard design= 112 for mineral oils  
Others on request

#### Fluid port

- 1 = carbon steel
- 2 = high tensile steel
- 3 = stainless steel <sup>4)</sup>
- 6 = low temperature steel

#### Accumulator shell

- 0 = plastic coated (internally)
- 1 = carbon steel
- 2 = chemically nickel-plated (internal coating)
- 4 = stainless steel <sup>4)</sup>
- 6 = low temperature steel

#### Accumulator bladder <sup>5)</sup>

- 2 = NBR <sup>6)</sup>
- 3 = ECO
- 4 = IIR
- 5 = NBR <sup>6)</sup>
- 6 = FKM
- 7 = other
- 9 = NBR <sup>6)</sup>

#### Certification code

U = European Pressure Equipment Directive (PED)  
For others, see section 2.5.

#### Permitted operating pressure [bar]

#### Connection, fluid side

Thread, codes for fluid port: A, C, E, G

- A = thread to ISO228 (BSP)
- B = thread to DIN13 or ISO965/1 (metric)
- C = thread to ANSI B1.1 (UN.-2B seal in acc. with SAE J 514)
- D = thread to ANSI B1.20.1 (NPT)
- S = special thread, to customer specification

Flange, codes for fluid port: F

- A = EN 1092-1 welding neck flange
- B = flange ASME B16.5
- C = SAE flange 3000 psi
- D = SAE flange 6000 psi
- S = special flange, to customer specification

#### Pre-charge pressure $p_0$ [bar] at 20 °C, must be stated clearly, if required!

<sup>1)</sup> See catalogue section Bladder accumulators Low pressure, No. 3.202

<sup>2)</sup> See catalogue section Hydraulic dampers, No. 3.701

<sup>3)</sup> See catalogue section Hydraulic accumulators with back-up nitrogen bottles, No. 3.553

<sup>5)</sup> When ordering a spare bladder, please state diameter of the smaller shell port

<sup>4)</sup> Dependent on type and pressure rating

<sup>6)</sup> Observe temperature ranges of the accumulator bladder, see section 2.1.3.

## 4. STANDARD ITEMS

The bladder accumulators and spare parts described below are manufactured in carbon steel with an NBR accumulator bladder (MC = 112).

The table provides the most important data and dimensions for the following series:

SB330/400/500/550/600, SB330H, SB330N

The part numbers provided refer to bladder accumulators in accordance with PED (CC = U) and ASME (CC = S).

Designs that differ from the standard types described below can be requested from HYDAC.

### 4.1. TECHNICAL DATA

#### 4.1.1 Permitted operating temperature

As standard, the part numbers listed in the table may be operated in the following temperature range:

-10 °C ... +80 °C

Other operating temperatures on request.

#### 4.1.2 Permitted operating pressure

The permitted operating pressure may differ from the nominal pressure in the case of other certifications. The table in section 4.2. shows the permitted operating pressures for the listed certification codes.

#### 4.1.3 Nominal volume

HYDAC bladder accumulators are available with set nominal volumes, see table in section 4.2.

#### 4.1.4 Effective gas volume

The effective gas volume is based on nominal dimensions. It differs slightly from the nominal volume and must be used when calculating the effective fluid volume see table in section 4.2.

#### 4.1.5 Effective volume

Volume of fluid which is available between the operating pressures  $p_2$  and  $p_1$ .

#### 4.1.6 Maximum flow rate of the operating fluid

In order to achieve the max. flow rate given in the tables, the accumulator must be installed vertically.

It must be ensured that a residual fluid volume of approx. 10 % of the effective gas volume remains in the accumulator.

The maximum fluid flow rate was determined under specific conditions and is not applicable in all operating conditions.

#### 4.1.7 Limits for gas pre-charge pressure

$$p_0 \leq 0.9 \cdot p_1$$

with a permitted pressure ratio of:

$$p_2 : p_0 \leq 4:1$$

$p_2$  = max. operating pressure

$p_0$  = pre-charge pressure

The specified values are maximum values and must not be considered as referring to a permanent load. The tolerable pressure ratio is influenced by the geometry, temperature, fluid and flow rate as well as any gas losses due to physical properties.

For more information, see catalogue section:

- HYDAC Accumulator Technology  
No. 3.000

#### 4.1.8 Gas side connection

Series	Volume [l]	Gas valve design
SB330 / SB400	< 1	5/8-18UNF
	< 50	7/8-14UNF
	≥ 50	M50x1.5 / 7/8-14UNF
SB500 / SB600	10 ... 50	M50x1.5 / 7/8-14UNF
SB550	1 ... 5	7/8-14UNF

Other pressure ratings on request

## 4.2. TABLES AND DRAWINGS

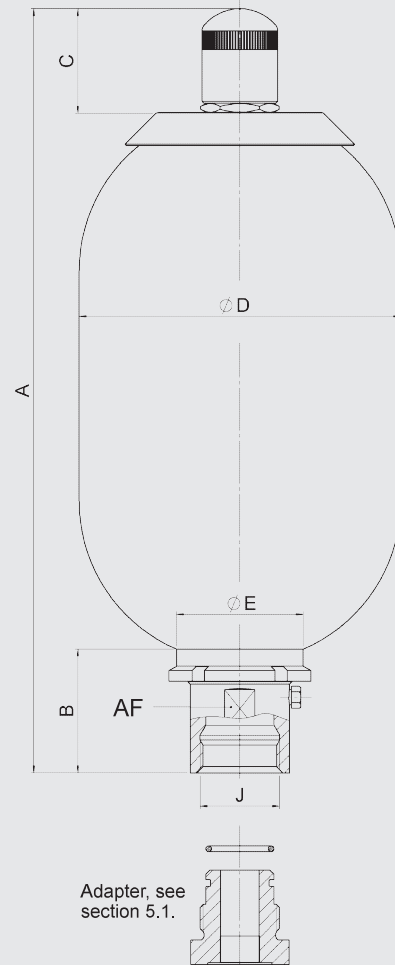

Nominal volume [l]	Series	Max. operating pressure				Eff. gas volume [l]	A max. [mm]	B [mm]	C [mm]	Ø D max. [mm]	J Thread ISO 228	Ø E [mm]	AF [mm]	Q max. 2) [l/s]	Weight [kg]	
		CC U		CC S												
		[bar]	Part no. 1)	[bar]	Part no. 1)											
0.5	SB400	400	3047163	–	–	0.5	270	57	33.5	96	G 3/4	50	32	4	4	
1	SB330	330	3047162	–	–	1	316	57	56	115	G 3/4	50	32	4	7	
	SB550 4)	550	3110531	–	–		343	67		123	G 1	67	45	6	10	
2.5	SB330	330	3047165	–	–	2.4	528	64	56	115	G 1 1/4	67	50	10	11	
	SB550 4)	550	3068916	–	–	2.5	550	67		123	G 1		45	6	14	
4	SB330	330	3047166	–	–	3.7	412	65	56	170	G 1 1/4	67	50	10	15	
	SB400 4)	400	3107905	–	–											
5	SB550 4)	550	3090654	–	–	4.9	876	64	56	123	G 1	67	45	6	27	
6	SB330	330	3047168	–	–	5.7	534	65	56	170	G 1 1/4	67	50	10	18	
10 3)	SB330	330	3047170	–	–	9.3	810	65	56	170	G 1 1/4	67	50	10	31	
10	SB330	330	3047172	262	3141237	9.3	582	101	56	229	G 2	100	70	15	33	
	SB330N		3156632	–	–									25	34	
	SB330H		3079081	–	–									9	617	136
	SB400 4)	400	3107393	290	–	9.3	578	101		69	241	G 2	100	70	15	46
	SB500 4)	500	3130252	–	–	8.8	598									
	SB600	–	–	345	332265	–	–	–		–	–	–	–	–	–	–
13	SB330	330	3047173	–	–	12	695	101	56	229	G 2	100	70	15	46	
	SB330N		–	–	–									25	47	
	SB330H		–	–	–									730	136	G 2 1/2
20	SB330	330	3047174	262	3117153	18.4	895	101	56	229	G 2	100	70	15	49	
	SB330N		3162982	–	–									25		–
	SB330H		3092659	–	–									17.5		930
	SB400 4)	400	3115007	290	–	18.4	895	101		69	241	G 2	100	70	71	
	SB500 4)	500	3118156	–	–	17	913									
	SB600	–	–	345	332266	–	–	–		–	–	–	–	–	–	–
24	SB330	330	3047175	–	–	23.6	1060	101	56	229	G 2	100	70	15	72	
	SB330N		–	–	–									25	73	
	SB330H		–	–	–									24	1095	136
32	SB330	330	3047176	262	3117154	33.9	1410	101	56	229	G 2	100	70	15	80	
	SB330N		3220899	–	–									25	81	
	SB330H		3059515	–	–									32.5	1445	136
	SB400 4)	400	3125141	290	–	33.9	1410	101		69	241	G 2	100	70	104	
	SB500 4)	500	3760577	–	–	33.5	1423									
	SB600	–	–	345	332267	–	–	–		–	–	–	–	–	–	–
50	SB330	330	3047177	262	362904	47.5	1933	101	69	229	G 2	100	70	15	114	
	SB330N		3185604	–	–									25	115	
	SB330H		3089605	–	–									1968	136	G 2 1/2
	SB400 4)	400	3114662	290	–	48.3	1933	101		69	241	G 2	100	70	137	
	SB500 4)	500	3130253	–	–											
	SB600	–	–	345	332268	–	–	–		–	–	–	–	–	–	–
60	SB330	330	3341217	–	–	60	1210	138	69	360	G 2 1/2	125	90	30	160	
80	SB330	330	–	–	–	85	1460	138	69	360	G 2 1/2	125	90	30	200	
100	SB330	330	3098489	–	–	105	1710	138	69	360	G 2 1/2	125	90	30	234	
130	SB330	330	–	–	–	133	2030	138	69	360	G 2 1/2	125	90	30	283	
160	SB330	330	–	–	–	170	2059	137	69	410	G 2 1/2	125	90	30	345	
200	SB330	330	–	–	–	201	2359	137	69	410	G 2 1/2	125	90	30	403	

1) If not specified, please request

2) Under optimum conditions

3) Slimline version, for confined installation spaces

4) Material code (MC) = 212 for AC U, see section 3.

### 4.3. SPARE PARTS

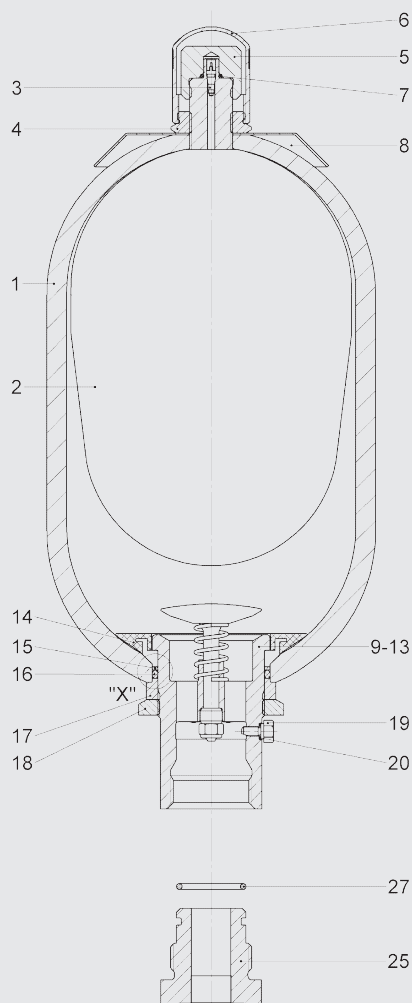

Description	Item
<b>Bladder assembly <sup>1)</sup></b>	
consisting of:	
Bladder	2
Gas valve insert <sup>2)</sup>	3
Lock nut	4
Seal cap	5
Protective cap	6
O-ring	7
<b>Seal kit</b>	
consisting of:	
O-ring	7
Washer	15
O-ring	16
Vent screw	19
Support ring	23 <sup>3)</sup>
O-ring	27 <sup>3)</sup>
<b>Repair kit <sup>1)</sup></b>	
consisting of:	
Bladder assembly (see above)	
Seal kit (see above)	
<b>Oil valve assembly</b>	
consisting of:	
Valve	9-13
Anti-extrusion ring <sup>2)</sup>	14
Washer	15
O-ring	16
Spacer	17
Groove nut	18
Vent screw	19
Support ring	23 <sup>3)</sup>

<sup>1)</sup> When ordering, please state diameter of the smaller shell port

<sup>2)</sup> Available separately

<sup>3)</sup> Not for all accumulator types

Accumulator shell (item 1) and company label (item 8) not available as spare part

Vent screw (item 19) for NBR/carbon steel: Seal ring (item 20) included

Adapter (item 25) incl. O-ring (item 27) available as an accessory, section 5.1.

#### Detail "X"

SB330/400 – 0.5 ... 6 l

SB330 – 10 l slimline version

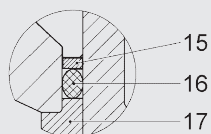

SB330/400/500/600 – 10 ... 50 l

SB330 - 60 ... 200 l

SB330H/N – 10 ... 50 l

SB550 – 1 ... 5 l

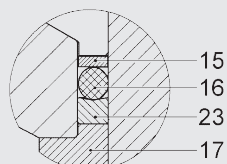

SB330/400, standard gas valve

Nominal volume [l]	Bladder assembly	Seal kit	Repair kit	Oil valve assembly	Anti-extrusion ring	Gas valve insert
0.5	365263	353606	2128169 <sup>1)</sup>	2102355	2105411	632865
1	237624		2106261			
2.5	236171	353609	2106200	236045	2105431	
4	236046		2106204	238523	2105451	
5	240917		2106208	236045	2105431	
6	2112097		2112100	238523	2105451	
10 <sup>2)</sup>	2127255 <sup>3)</sup>		3117512 <sup>3)</sup>			
10	236088		353621	2106212	352572	
13	376249	2106216				
20	236089	2106220				
24	376253	2106224				
32	235335	2106228				
50	235290	2106252				
60	3364274	3102043 <sup>3)</sup>	3117513	3273734	3102326	
80	3364312		3117514			
100	3127313		3117515			
130	3201384		3117516			
160	3184769		3117517			
200	3461300		3117558			

Others on request

<sup>1)</sup> Only for SB400

<sup>2)</sup> Slimline version, for confined installation spaces

<sup>3)</sup> Only for SB330

## 5. ACCESSORIES

### 5.1. ADAPTERS FOR STANDARD BLADDER ACCUMULATORS (FLUID SIDE)

To connect the bladder accumulator to threaded pipe fittings. These are available separately

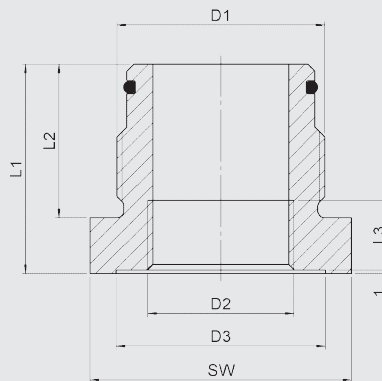

D1 Accum.conn.* ISO 228-BSP	D2 ISO 228-BSP	D3 [mm]	L1 [mm]	L2 [mm]	L3 [mm]	AF [mm]	O-ring [mm]	Part no. NBR/carbon steel
G 3/4	G 3/8	28	55	28	12	32	17x3	2104346
	G 1/2				14	36		2104348
G 1 1/4	G 3/8	28	50	37	12	46	30x3	2116345
	G 1/2				14			2105232
	G 3/4				16			2104384
	G 1				18			2110124
G 2	G 1/2	34	60	44	14	65	48x3.15	2104853
	G 3/4				16			2104849
	G 1				18			2124831
	G 1 1/4				20			2107113
	G 1 1/2				22			2105905
G 2 1/2	G 1 1/4	60	66	50	20	80	62x4	2127406
	G 1 1/2				22			3243831
	G 2				27			100

\* Others on request

## 5.2. ADAPTERS (GAS SIDE)

The adapters shown below are available for standard connections on bladder accumulators and must be specified separately in the order.

Fundamentally, the permitted operating pressure for the specified assembly numbers must not exceed 400 bar.

The upper limit of the pressure gauge must be observed, however.

### 5.2.1 Adapter for safety devices

Adapter for connecting safety devices, such as burst discs or temperature fuses, see catalogue section:

- Safety equipment for hydraulic accumulators  
No. 3.552

### 5.2.2 Pressure gauge model

Gas-side connection on the bladder accumulator for permanent monitoring of the pre-charge pressure.

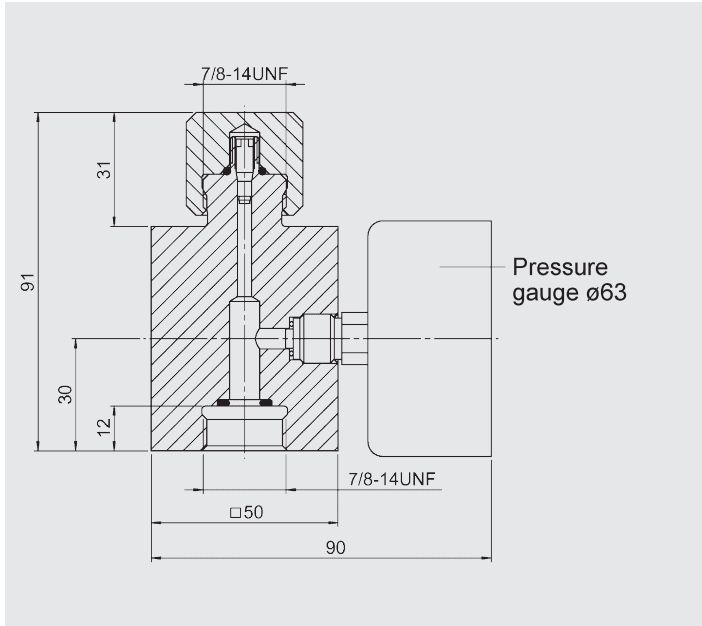

Gauge indication range	Pressure gauge Part no.	Adapter assembly Part no.
–	–	366621
0 - 10 bar	614420	2108416
0 - 60 bar	606886	3093386
0 - 100 bar	606887	2104778
0 - 160 bar	606888	3032348
0 - 250 bar	606889	2100217
0 - 400 bar	606890	2102117

### 5.2.3 Pressure gauge model with shut-off valve

Gas side connection on the bladder accumulator for permanent monitoring of the pre-charge pressure with shut-off option.

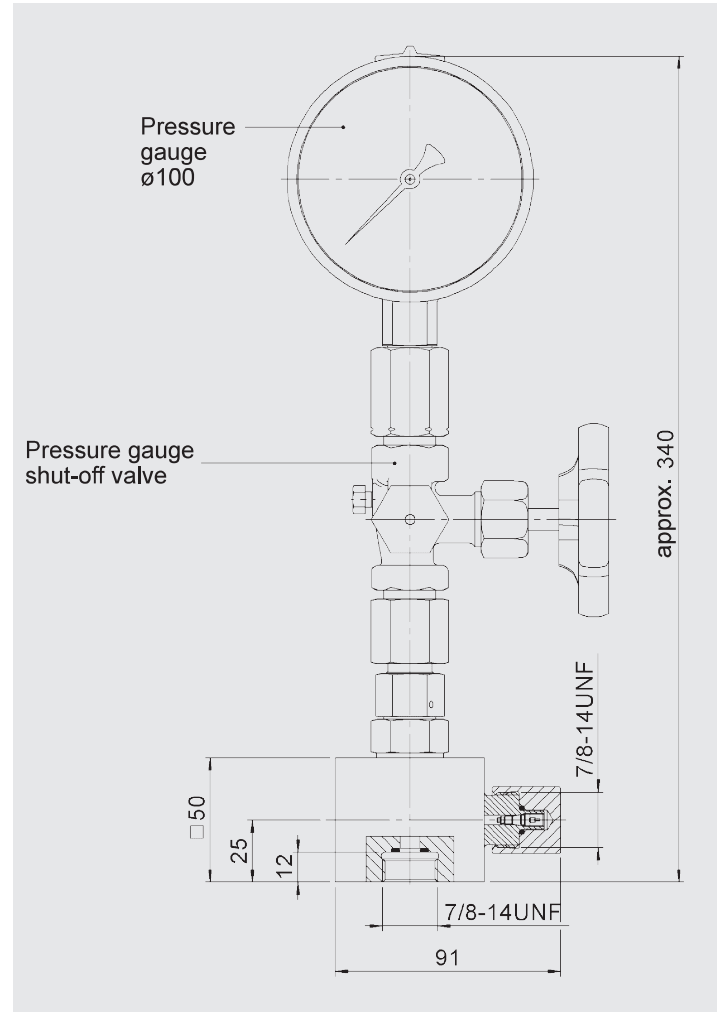

Gauge indication range	Pressure gauge Part no.	Adapter assembly Part no.
–	–	2103381
0 - 25 bar	617928	3784725
0 - 60 bar	606771	2110059
0 - 100 bar	606772	3139314
0 - 160 bar	606773	3202970
0 - 250 bar	606774	3194154
0 - 400 bar	606775	2103226

### 5.2.4 Remote monitoring of the pre-charge pressure

To monitor the pre-charge pressure in hydraulic accumulators remotely, gas-side adapters with a pressure gauge and mounting bores are available.

In order to connect these adapters directly to the hydraulic accumulator using appropriate pipework, accumulator connectors are also available for connection at the top (see figure 1) or for connection at the side (see figure 2).

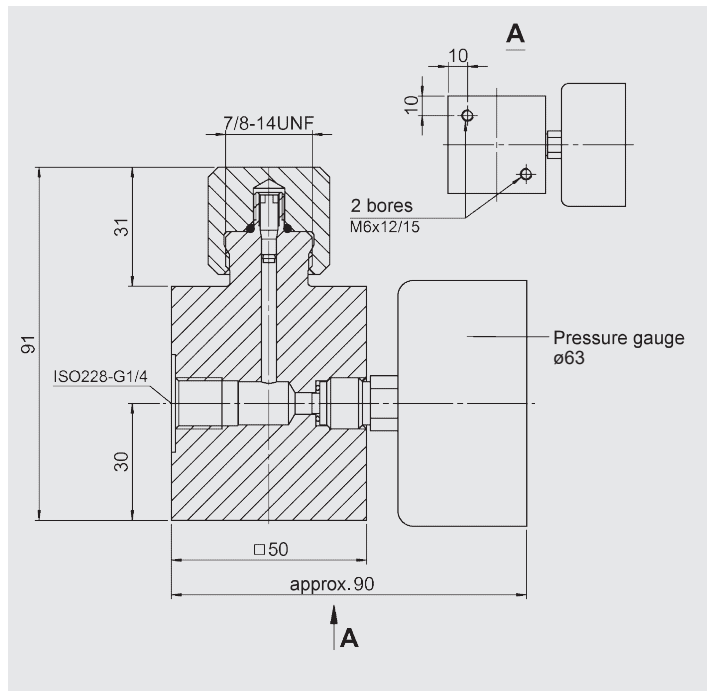

Gauge indication range	Pressure gauge Part no.	Adapter assembly Part no.
-	-	3037666
0 - 10 bar	614420	3095818
0 - 60 bar	606886	3095819
0 - 100 bar	606887	3095820
0 - 160 bar	606888	3095821
0 - 250 bar	606889	3095822
0 - 400 bar	606890	3095823

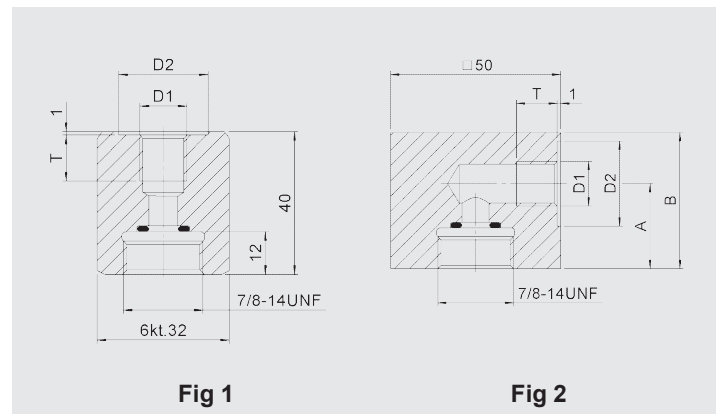

D1 Threaded connection	D2 [mm]	T [mm]	A [mm]	B [mm]	Adapter assembly Part no.	Fig.
ISO228 - G 1/4	25	14	-	-	2109481	1
			25	40	2102042	2
ISO228 - G 3/8	28	14	-	-	2109483	1
			25	40	366607	2
ISO228 - G 1/2	34	16	-	-	2110636	1
			31	55	366608	2

### 5.3. TRANSPORT EQUIPMENT FOR BLADDER ACCUMULATORS

Various types of transport equipment are available for transporting standard bladder accumulators. The weights of the bladder accumulators are given in section 4.2.

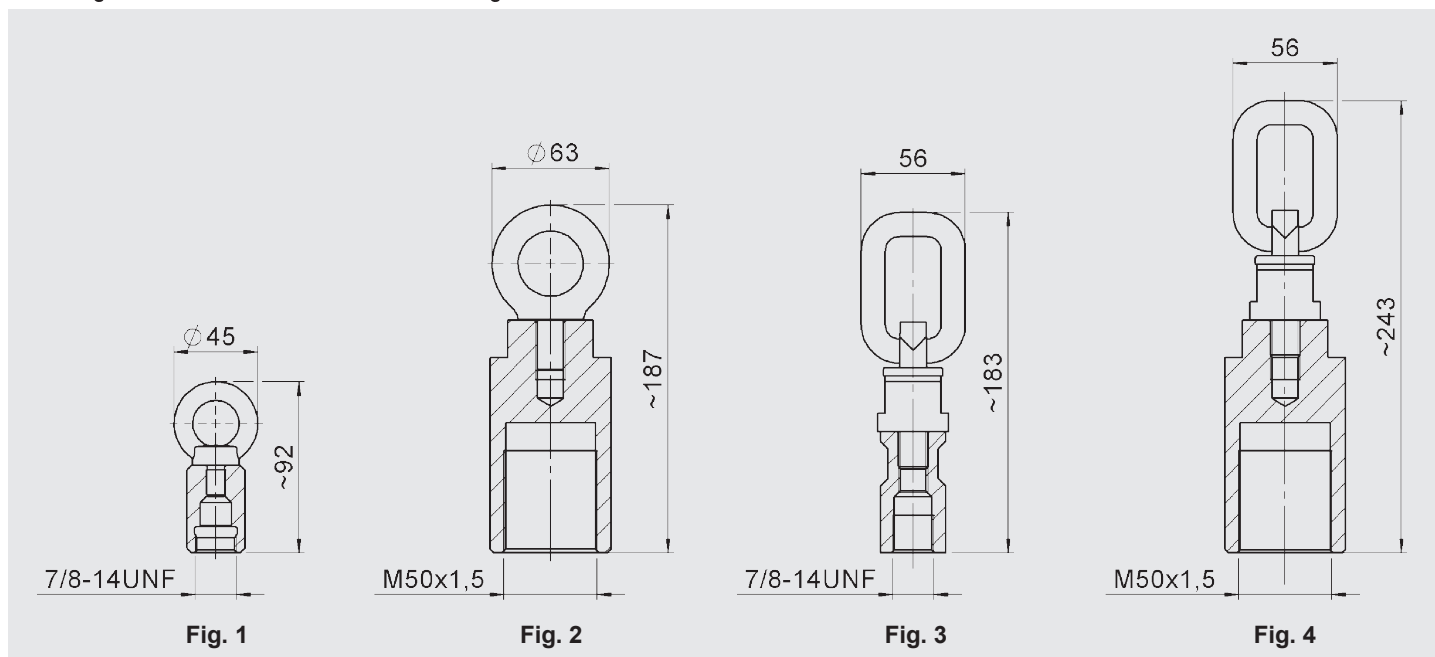

Material	Part no.	Gas side connection	max. [kg]	Special feature	Fig.
Carbon steel	4356969	7/8-14UNF	350	-	1
	4356971	M50x1,5	350	-	2
	4152199	7/8-14UNF	1120	swivel-type	3
	4356954	M50x1,5	1120	swivel-type	4

Others on request

### 6. NOTE

The information in this brochure relates to the operating conditions and fields of application described. For applications and/or operating conditions not described, please contact the relevant technical department. Subject to technical modifications.

**HYDAC Technology GmbH**  
 Industriegebiet  
**66280 Sulzbach/Saar, Germany**  
 Tel.: +49 68 97 / 509 - 01  
 Internet: [www.hydac.com](http://www.hydac.com)  
 E-mail: [speichertechnik@hydac.com](mailto:speichertechnik@hydac.com)