



Hydraulic dampers

1. DESCRIPTION

1.1. FUNCTION

The pressure fluctuations occurring in hydraulic systems can be cyclical or one-off problems due to:

- Flow rate fluctuations from displacement pumps
- Actuation of shut-off and control valves with short opening and closing times
- Switching on and off of pumps
- Sudden linking of spaces with different pressure levels

HYDAC hydraulic dampers are particularly suitable for damping such pressure fluctuations. Selecting the most suitable hydraulic damper for each system ensures that:

- Reduction in piping, valve and coupling vibrations, for example
→ less piping damage
- Protection of valves and measuring instruments
- Reduction in noise
- Improvement in machine tool performance
- Interconnection of several pumps in one line is possible
- A pump rpm and feed pressure increase is possible
- The maintenance and servicing costs can be reduced
- The service life of the system is increased

In addition to hydraulic dampers, HYDAC supplies fluid silencers, see catalogue section:

- Silencers
No. 3.702



1.2. DESIGN, MODE OF OPERATION

Pulsation dampers

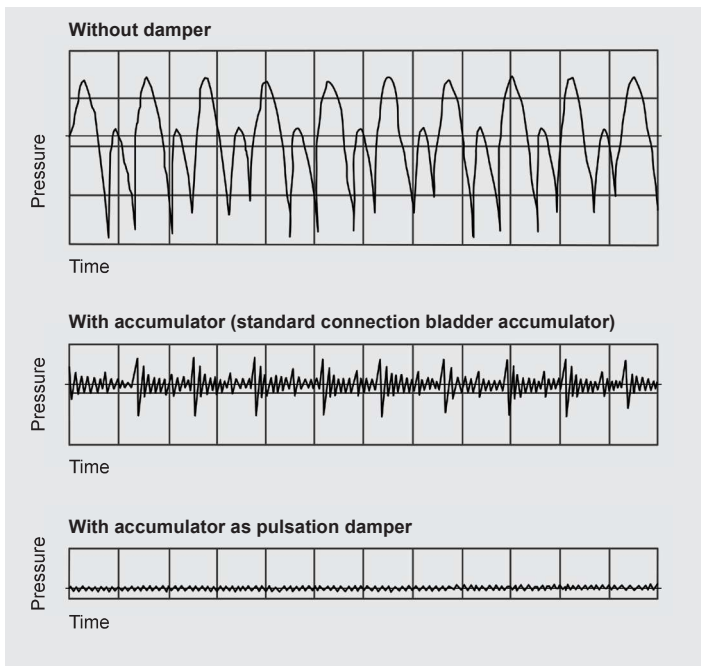

Design

HYDAC pulsation dampers consist of the following key individual components:

- Welded or forged pressure vessel in carbon steel, available with internal coating or in stainless steel for chemically aggressive fluids
- Special fluid valve with inline connection, which guides the flow into the vessel (threaded or flange connection)
- Bladder or diaphragm in various elastomers as shown in section 2.1.3

Mode of operation

The pulsation damper generally has two fluid ports and can therefore be fitted directly inline.

The flow is diverted in the fluid valve so that it is directed straight at the bladder or diaphragm. This causes direct contact of the flow with the bladder or diaphragm which, in an almost inertialess operation, balances the flow rate fluctuations via the gas volume. It particularly compensates for higher frequency pressure oscillations. The charge pressure is adjusted to individual operating conditions.

Applications

HYDAC pulsation dampers prevent pipe breaks caused by material fatigue, pipe oscillations and irregular flow rates. This protects valves, control devices and other instruments and reduces noise.

They are used in hydraulic systems, displacement pumps, sensitive measurement and control instruments and piping with extensive branching, e.g. in process circuits in the chemicals industry.

Suction flow stabilisation

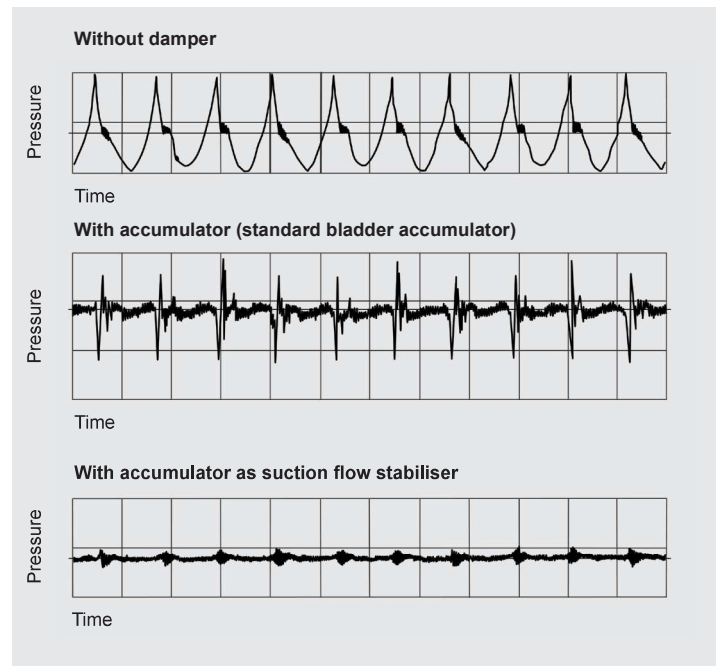

Design

HYDAC suction flow stabilisers consist of the following key individual components:

- Welded vessel made from carbon steel or stainless steel
- The inlet and outlet are on opposite sides and are separated by a baffle, other versions on request
- Encapsulated bladder in the upper part
- Vent screw in end cap and a drainage facility on the bottom

Mode of operation

Trouble-free pump operation is only possible if no cavitation occurs in the pump suction and pipe oscillations are prevented.

A relatively high fluid volume in the suction flow stabiliser in relation to the displacement volume of the pump reduces the acceleration effects of the fluid column in the suction line.

An air separation is also achieved due to the extremely low flow rate in the suction flow stabiliser and the deflection on a baffle. By adjusting the charging pressure of the bladder to the operating conditions, the best possible damping is achieved.

Applications

HYDAC suction flow stabilisers improve the NPSH value of the system, avoid pump cavitation and prevent pipe oscillations.

Their main application areas are piston and diaphragm pumps in public utility plants and the chemical industry.

Shock absorption

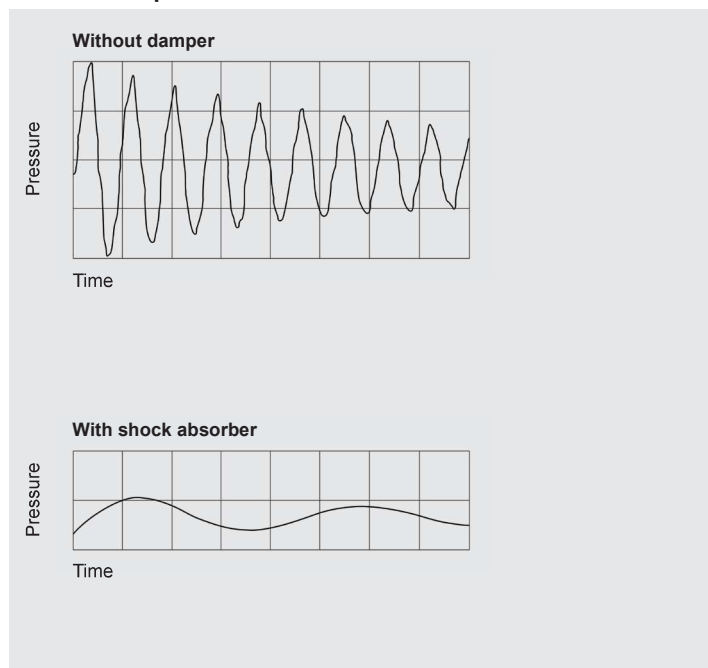

Design

Shock absorption can be provided by using bladder, piston and diaphragm accumulators. Further technical details on the individual accumulator types can be found in the following catalogue sections:

- Bladder accumulators Low pressure
No. 3.202
- Bladder accumulators Standard design
No. 3.201
- Diaphragm accumulators
No. 3.100
- Piston accumulators Standard design
No. 3.301

Mode of operation

Sudden changes in pipeline flow, such as those caused by pump failure or the closing or opening of valves, can cause pressures which are many times higher than the normal values. The shock absorber prevents this by converting potential energy into kinetic energy and vice versa. This prevents pressure shocks and protects pipelines, valves, monitoring instruments and other pipe fittings from destruction.

Applications

HYDAC shock absorbers reduce pressure shocks and protect pipelines and other pipe fittings from destruction.

They are used in pipelines with quick-acting valves or flaps and whilst pumps are being switched on and off. They are also suitable for energy storage in low pressure applications.

1.3. SIZING

1.3.1 PULSATION DAMPER AND SUCTION FLOW STABILISER

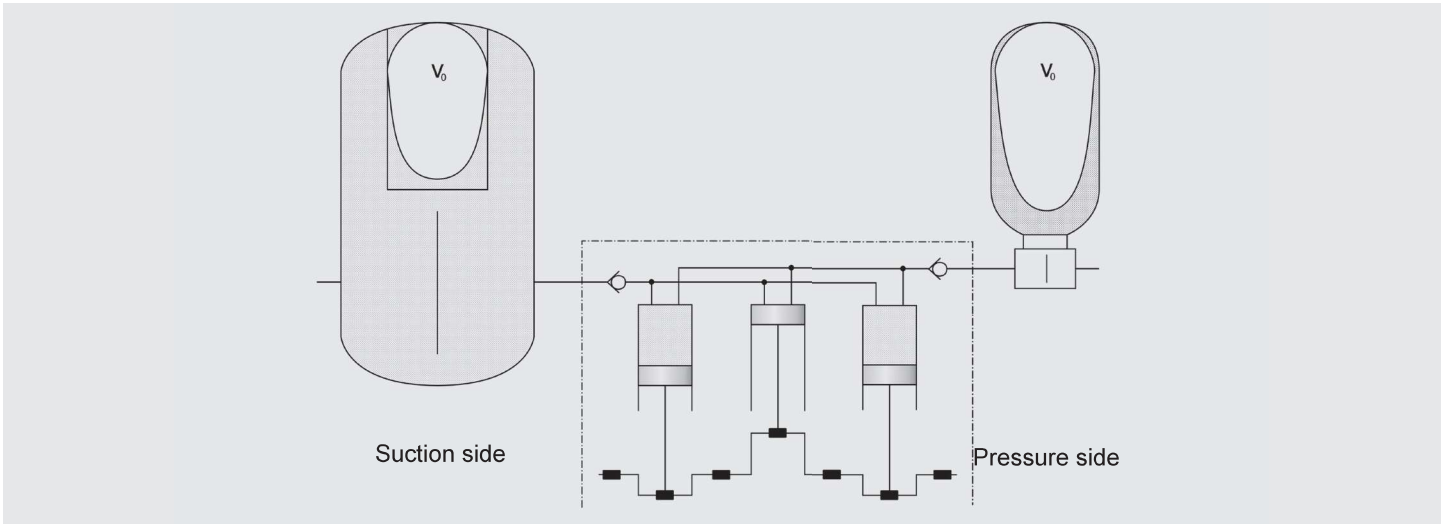

On the suction side and the pressure side of piston pumps there are almost identical conditions in terms of the irregularity of the flow rate. Therefore, the same formulae for determining the effective gas volume are used to calculate the damper size. The fact that two completely different damper types are ultimately used is due to the different acceleration and pressure ratios on the two sides.

When selecting the pulsation damper, it is not only the gas volume V_0 which is the decisive factor. The connection size to the pump also has to be taken into account.

In order to avoid additional cross-section variations, which represent reflection points for vibrations, and to keep pressure drop to a reasonable level, the fitting cross section of the damper must be the same as that of the pipeline.

The gas volume V_0 of the damper is determined with the aid of the formula for adiabatic changes of state.

By giving the residual pulsation or the gas volume, the damper size can be dimensioned with the aid of the HYDAC software **ASP** (Accumulator Simulation Program).

Designations:

ΔV = fluctuating fluid volume [l]

$$\Delta V = m \cdot q$$

q = stroke volume [l]

$$q = \frac{\pi \cdot d_k^2}{4} \cdot h_k$$

d_k = piston diameter [dm]

h_k = piston stroke [dm]

m = amplitude factor

$$m = \frac{\Delta V}{q}$$

z = no. of compressions or effective cylinders per revolution

x = residual pulsation [\pm %]

κ = isentropic exponent

Φ = pressure ratio of pre-charge pressure to operating pressure [0.6 ... 0.9]

$$\Phi = \frac{p_0}{p_m}$$

Δp = amplitude of pressure fluctuations

$$\Delta p = p_2 - p_1 \text{ [bar]}$$

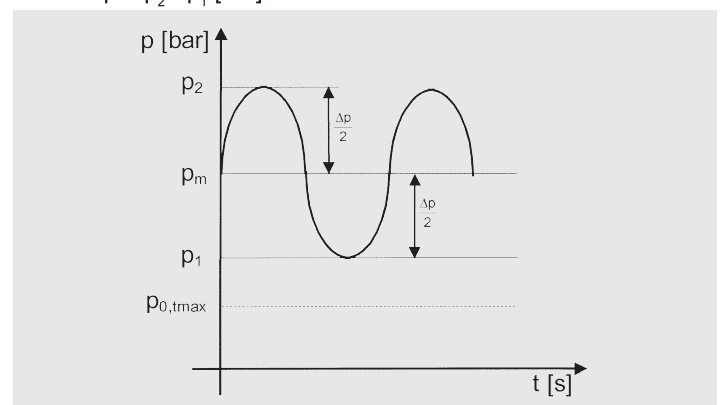

Formulae:

$$V_0 = \frac{\Delta V}{\left[\frac{\Phi}{1 - \frac{x}{100}} \right]^{\frac{1}{\kappa}} - \left[\frac{\Phi}{1 + \frac{x}{100}} \right]^{\frac{1}{\kappa}}}$$

$$\Delta V = m \cdot q$$

$$x [\pm \%] = \left| \frac{p_1 - p_m}{p_m} \cdot 100 \right|$$

$$= \left| \frac{p_2 - p_m}{p_m} \cdot 100 \right|$$

Diagram of mounting options:

Preferred installation configuration with maximum damping effect

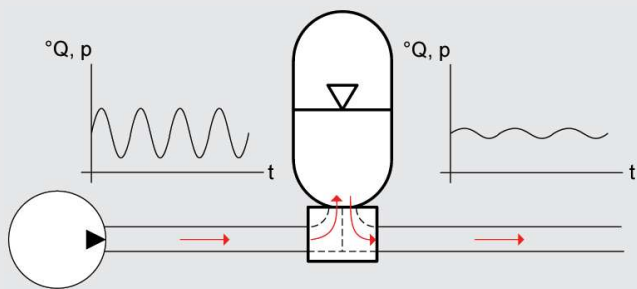

Alternative installation configuration using standard accumulator with a T-piece with reduced damping effect

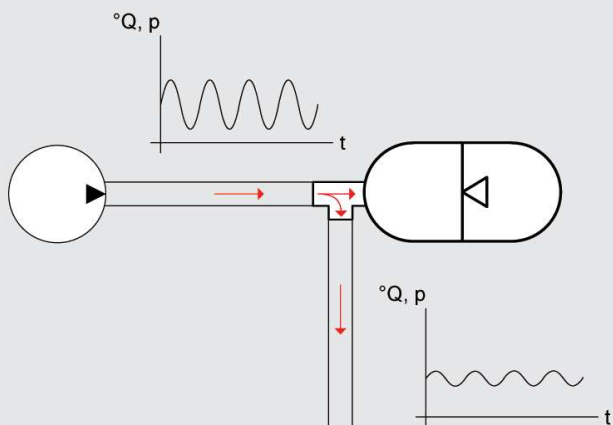

Isentropic exponent κ dependent on pressure and temperature:

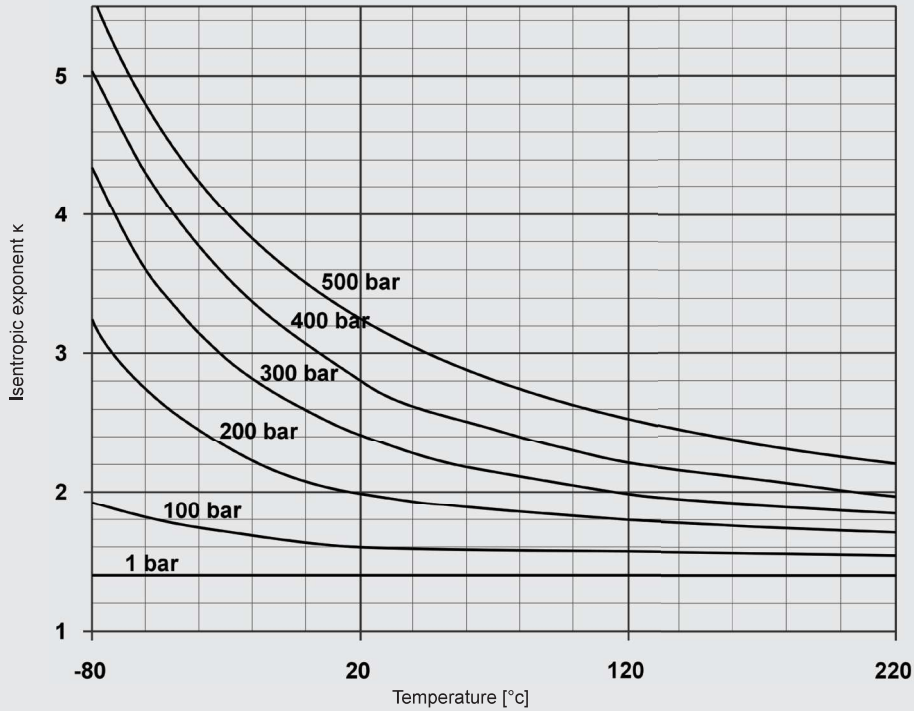

Amplitude factor (m) for piston pump:

z	m value	
	single acting	double acting
1	0.548	0.206
2	0.206	0.042
3	0.035	0.018
4	0.042	0.010
5	0.010	0.007
6	0.018	0.005
7	0.005	
8	0.010	
9	0.001	

Others on request

1.3.2 Calculation example

Given parameters:

Single-acting 3-piston pump

Piston diameter:	70 mm
Piston stroke:	100 mm
Drive speed:	370 rpm
Flow rate:	427 l/min
Operating temperature:	20 °C
Operating pressure, pressure side:	200 bar
Operating pressure, suction side:	4 bar

Required:

- Suction flow stabiliser for a residual pulsation of $\pm 2.5\%$
- Pulsation damper for a residual pulsation of $\pm 0.5\%$

Solution:

a) Determining the required suction flow stabiliser

$$V_0 = \frac{\Delta V}{\left[\left(\frac{\Phi}{1 - \frac{x}{100}} \right)^{\frac{1}{\kappa}} - \left(\frac{\Phi}{1 + \frac{x}{100}} \right)^{\frac{1}{\kappa}} \right]}$$

$$V_0 = \frac{0,035 \cdot \frac{\pi \cdot 0,7^2}{4} \cdot 1,0}{\left[\left(\frac{0,6}{1 - \frac{2,5}{100}} \right)^{\frac{1}{1,4}} - \left(\frac{0,6}{1 + \frac{2,5}{100}} \right)^{\frac{1}{1,4}} \right]}$$

$$V_0 = 0.54 \text{ l}$$

Selected: SB16S-12 with 1 litre gas volume

b) Determining the required pulsation damper

$$V_0 = \frac{\Delta V}{\left[\left(\frac{\Phi}{1 - \frac{x}{100}} \right)^{\frac{1}{\kappa}} - \left(\frac{\Phi}{1 + \frac{x}{100}} \right)^{\frac{1}{\kappa}} \right]}$$

$$V_0 = \frac{0,035 \cdot \frac{\pi \cdot 0,7^2}{4} \cdot 1,0}{\left[\left(\frac{0,7}{1 - \frac{0,5}{100}} \right)^{\frac{1}{2,0}} - \left(\frac{0,7}{1 + \frac{0,5}{100}} \right)^{\frac{1}{2,0}} \right]}$$

$$V_0 = 3.2 \text{ l}$$

Selected: SB330P-4

1.3.3 SHOCK ABSORBER

Pressure shock produced when a valve is closed without a hydraulic accumulator

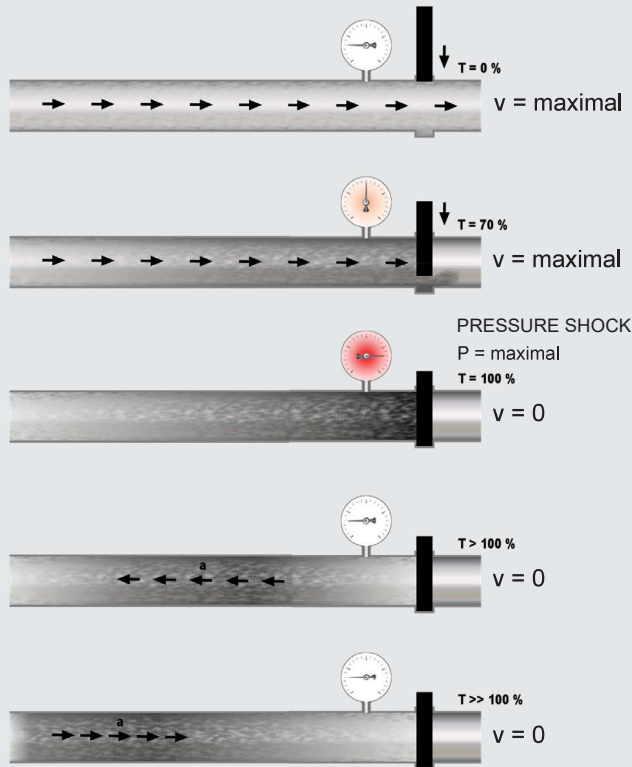

Simplified pressure shock calculation for the closing of a valve.

Estimate of Joukowsky's max. occurring pressure shock

$$\Delta p [\text{N/m}^2] = \rho \cdot a \cdot \Delta v$$

ρ [kg/m³] = fluid density

Δv = $v - v_1$

Δv = change in fluid velocity

v [m/s] = fluid velocity before the change in its condition

v_1 [m/s] = fluid velocity after the change in its condition

a [m/s] = propagation velocity of pressure wave

$$a [\text{m/s}] = \frac{1}{\sqrt{\rho \cdot \left[\frac{1}{K} + \frac{D}{E \cdot e} \right]}}$$

K [N/m²] = compression modulus of the fluid

E [N/m²] = elasticity modulus of the pipeline

D [mm] = internal diameter of the pipeline

e [mm] = wall thickness of the pipeline

The pressure wave runs to the other end of the pipeline and will reach the valve again after time t (reflection time), whereby:

$$t [\text{s}] = \frac{2 \cdot L}{a}$$

L [m] = length of the pipeline

T [s] = eff. operating time (closing) of the valve

If $T < t$ then: $p_{\text{max}} = p_1 + \Delta p$

If $T > t$ then: $p_{\text{max}} = p_1 + \rho \cdot a \cdot \Delta v \cdot \frac{t}{T}$

Determining the required damper size

The accumulator must absorb the kinetic energy of the fluid by converting it into potential energy within the pre-determined pressure range. The change of state of the gas is adiabatic in this case.

$$V_0 = \frac{m \cdot \Delta v^2 \cdot 0,4}{2 \cdot p_1 \cdot \left[\left(\frac{p_2}{p_1} \right)^{\frac{1}{\kappa}} - 1 \right] \cdot 10^2} \cdot \left(\frac{p_1}{p_0} \right)^{\frac{1}{\kappa}}$$

m [kg] = weight of the fluid in the pipeline

v [m/s] = change in velocity of the fluid

p_1 [bar] = zero head of the pump

p_2 [bar] = perm. operating pressure

p_0 [bar] = pre-charge pressure

A special calculation program for analysing the pressure curve is available for manifold sizing or sizing with regards to pump failure or start-up.

1.3.4 Calculation example

Rapid closing of a shut-off valve in a re-fuelling line

Given parameters:

Length of pipeline L:	2000 m
Size of pipeline D:	250 mm
Wall thickness of pipeline e:	6.3 mm
Material of the pipeline:	Steel
Flow rate Q:	432 m ³ /h = 0.12 m ³ /s
Density of medium ρ:	980 kg/m ³
Zero feed height of pump p ₁ :	6 bar
Min. operating pressure p _{min} :	4 bar
Eff. closing time of valve T:	1.5 s (approx. 20% of total closing time)
Operating temperature:	20 °C
Compression modulus of fluid K:	1.62 × 10 ⁹ N/m ²
Elasticity modulus (steel) E:	2.04 × 10 ¹¹ N/m ²

Required:

Size of required shock absorber when the max. pressure (p₂) must not exceed 10 bar.

Solution:

Determination of reflection time:

$$a = \frac{1}{\sqrt{\rho \cdot \left[\frac{1}{K} + \frac{D}{E \cdot e} \right]}}$$

$$a = \frac{1}{\sqrt{980 \cdot \left[\frac{1}{1.62 \cdot 10^9} + \frac{250}{2.04 \cdot 10^{11} \cdot 6.3} \right]}}$$

$$a = 1120 \text{ m/s}$$

$$t = \frac{2 \cdot L}{a} = \frac{2 \cdot 2000}{1120} = 3.575 \text{ s} *$$

* Since T < t, the max. pressure shock occurs and the formula as shown in section 1.3.3 must be used.

$$v = \frac{Q}{A}$$

$$v = \frac{0.12}{0.25^2 \cdot \frac{\pi}{4}} = 2.45 \text{ m/s}$$

$$\Delta_p = \rho \cdot a \cdot \Delta v$$

$$\Delta_p = 980 \cdot 1120 \cdot (2.45 - 0) \cdot 10^{-5} = 26.89 \text{ bar}$$

$$p_{\max} = p_1 + \Delta_p$$

$$p_{\max} = 6 + 26.89 = 32.89 \text{ bar}$$

Determining the required gas volume:

$$p_0 \leq 0.9 \cdot p_{\min}$$

$$p_0 \leq 0.9 \cdot 5 = 4.5 \text{ bar}$$

$$V_0 = \frac{m \cdot v^2 \cdot 0.4}{2 \cdot p_1 \cdot \left[\left(\frac{p_2}{p_1} \right)^{\frac{1}{\kappa}} - 1 \right] \cdot 10^2} \cdot \left(\frac{p_1}{p_0} \right)^{\frac{1}{\kappa}}$$

$$\text{with } m = V \cdot \rho = \frac{\pi}{4} \cdot D^2 \cdot L \cdot \rho$$

$$V_0 = \frac{\frac{\pi}{4} \cdot 0.25^2 \cdot 2000 \cdot 980 \cdot 2.45^2 \cdot 0.4}{2 \cdot 7 \cdot \left[\left(\frac{11}{7} \right)^{\frac{1}{1.4}} - 1 \right] \cdot 10^2} \cdot \left(\frac{7}{4.5} \right)^{\frac{1}{1.4}}$$

$$V_0 = 1641 \text{ l}$$

Selected:

4 shock absorbers
SB35AH-450

2. GENERAL INFORMATION

2.1. MATERIALS, CORROSION PROTECTION

2.1.1 Accumulator shell

The accumulator shells are made from carbon steel as standard. For operation with chemically aggressive media, the accumulator shell can be supplied with corrosion protection (such as chemical nickel-plating). If this is insufficient, then stainless steel hydraulic dampers must be used.

For special requirements, high-resistance plastic accumulator shells are available.

2.1.2 Bladder/diaphragm

The elastomer material must be selected in accordance with the particular operating medium or operating temperature, see section 2.1.3. If discharge conditions are unfavourable (high p_2/p_0 pressure ratio, rapid discharge speed), the gas may cool to below the permitted temperature. This can cause cold cracking. The gas temperature can be calculated using the HYDAC Accumulator Simulation Program **ASP**.

2.1.3 Maximum temperature range of elastomer materials

The permitted working temperature of a hydraulic damper is dependent on the application of the metal materials and the separation element. The operating medium must also be taken into account.

The following table shows the main **elastomer materials with their maximum possible temperature ranges** with examples of operating fluids.

Materials		Material code ¹⁾	Accumulator type	Max. possible temperature range ²⁾	Possible operating fluids, others on request	
					Resistant to	Not resistant to
NBR	Acrylonitrile butadiene rubber	2	SB, SBO	-15 °C ... + 80 °C	<ul style="list-style-type: none"> - Mineral oil (HL, HLP) - Flame-retardant fluids from the groups HFA, HFB, HFC - Synthetic esters (HEES) - Water - Sea water 	<ul style="list-style-type: none"> - Aromatic hydrocarbons - Chlorinated hydrocarbons (HFD-S) - Amines and ketones - Hydraulic fluids from the group HFD-R - Fuels
		5	SB, SBO	-50 °C ... + 50 °C		
		9	SB, SBO	-30 °C ... + 80 °C		
ECO	Ethylene oxide epichlorohydrin rubber	3	SB	-30 °C ... +120 °C	<ul style="list-style-type: none"> - Mineral oil (HL, HLP) - Flame-retardant fluids from the HFB group - Synthetic esters (HEES) - Water - Sea water 	<ul style="list-style-type: none"> - Aromatic hydrocarbons - Chlorinated hydrocarbons (HFD-S) - Amines and ketones - Hydraulic fluids from the group HFD-R - Flame-retardant fluids from the groups HFA and HFC - Fuels
			SBO	-40 °C ... +120 °C		
IIR	Butyl rubber	4	SB	-50 °C ... +100 °C	<ul style="list-style-type: none"> - Hydraulic fluids from the group HFD-R - Flame-retardant fluids from the group HFC - Water 	<ul style="list-style-type: none"> - Mineral oils and greases - Synthetic esters (HEES) - Aliphatic, chlorinated and aromatic hydrocarbons - Fuels
			SBO	-50 °C ... +120 °C		
FKM	Fluorine rubber	6	SB, SBO	-10 °C ... +150 °C	<ul style="list-style-type: none"> - Mineral oil (HL, HLP) - Hydraulic fluids from the group HFD - Synthetic esters (HEES) - Fuels - Aromatic hydrocarbons - Inorganic acids 	<ul style="list-style-type: none"> - Amines and ketones - Ammonia - Skydrol and HyJet IV - Steam

¹⁾ The material code (MC) is described in more detail in the model code, see section 3.

²⁾ The specified temperature range relates to the particular elastomer material, not to the operating range of the hydraulic accumulator, see section 4.1.1

2.2. INSTALLATION POSITION

Pulsation damper

As close as possible to the pulsation source.
Mounting position preferably vertical (gas valve pointing upwards). Preferred and alternative installation positions are shown in schematic form in section 1.3.

Suction flow stabiliser

As close as possible to the suction inlet of the pump.
Vertical mounting position (gas valve pointing upwards).

Shock absorber

As close as possible to the source of the erratic condition.
Vertical mounting position (gas valve pointing upwards).

2.3. TYPE OF INSTALLATION

Hydraulic dampers with large volumes are generally designed with corresponding mounting devices.

Bladder accumulator and diaphragm accumulator pulsation dampers are fitted directly inline.

In the case of strong vibrations and wherever these are possible, we recommend using HYDAC mounting elements, see catalogue section:

- Mounting elements for hydraulic accumulators
No. 3.502

2.4. CHARGING GAS

- Charging gas: Nitrogen
- Specification: min. Class 2.8

If other gases are to be used or if these specifications are deviated from, please contact HYDAC.

2.5. CERTIFICATES

Hydraulic dampers that are installed outside of Germany are supplied with the relevant test certificate documentation. The country of installation must be stated at the time of ordering. HYDAC pressure vessels can be supplied with almost any approval classification. The permitted operating pressure may differ from the nominal pressure.

The following table provides some examples of the code in the model code:

Country	Certificate code (CC)
EU member states	U
Australia	F ¹⁾
Belarus	A6
Canada	S1 ¹⁾
China	A9
Great Britain	Y
Hong Kong	A9
Iceland	U
Japan	P
Korea (Republic of)	A11
New Zealand	T
Norway	U
Russia	A6
South Africa	S2
Switzerland	U
Turkey	U
Ukraine	A10
USA	S

¹⁾ Registration required in the individual territories or provinces.
Others on request

2.6. FURTHER INFORMATION

- Operating instructions for bladder accumulators
No. 3.201.BA
- Operating instructions for piston accumulators
No. 3.301.BA
- Operating instructions for diaphragm accumulators
No. 3.100.BA

The operating instructions must be observed!

All work on HYDAC diaphragm dampers must only be carried out by suitably trained staff. Incorrect installation or handling can lead to serious accidents.

Further information such as accumulator sizing, safety information and extracts from the acceptance specifications can be found in our overview catalogue section:

- HYDAC Accumulator Technology
No. 3.000

This document and others are available from our Download Center at www.hydac.com.

3. MODEL CODE

Not all combinations are possible. Order example.
For further information, please contact HYDAC.

SB330 P - 10 A 1 / 112 U - 330 AI

Series

SB... = with bladder
SBO... = with diaphragm

Type code

A = shock absorber
AH = high flow shock absorber
P = pulsation damper
PH = high flow pulsation damper
S = suction flow stabiliser

Nominal volume [l]

Fluid port

A = threaded connection
E = threaded connection for weld type construction (diaphragm accumulators only)
F = flange ¹⁾

Type code

1 = standard version (not for screw type diaphragm accumulators or shock absorbers)
2 = back-up version ²⁾
6 = standard version for screw type diaphragm accumulators of type SBO...P-...A6
7 = M28x1.5 gas valve (only for SB16/35)

Material code (MC)

Dependent on operating medium
Standard design = 112 for mineral oils
Others on request

Fluid port

1 = carbon steel
2 = high tensile steel
3 = stainless steel ³⁾
4 = chemically nickel-plated (internal coating) ²⁾
6 = low temperature steel
7 = other materials

Accumulator shell

0 = plastic (inner coating) ²⁾
1 = carbon steel
2 = chemically nickel-plated (inner coating) ²⁾
4 = stainless steel ^{2) 3)}
6 = low temperature steel
7 = other materials

Accumulator bladder ⁴⁾ / diaphragm

2 = NBR ⁵⁾
3 = ECO
4 = IIR
5 = NBR ⁵⁾
6 = FKM
7 = other materials (e.g. PTFE, EPDM, ...)
9 = NBR ⁵⁾

Certification code

U = European Pressure Equipment Directive (PED)
For others, see section 2.5.

Permitted operating pressure [bar]

Connection, fluid side

AI = ISO 228 (BSP), standard connection
BI = DIN 13 in acc. with ISO 965/1 (metric) ¹⁾
CI = ANSI B1.1 (UNF thread, sealing to SAE standard) ¹⁾
DI = ANSI B1.20 (NPT thread) ¹⁾

SBO250P-0075E1 and for SBO210P-0.16E1:

AK = ISO 228 (BSP), standard connection

¹⁾ Specify full details of version

²⁾ Not available for all versions

³⁾ Dependent on type and pressure rating

⁴⁾ When ordering a spare bladder, please state diameter of the smallest shell port

⁵⁾ Observe temperature ranges, see section 2.1.3

4. STANDARD ITEMS

The hydraulic dampers and any spare parts described below are manufactured in carbon steel with an NBR diaphragm and/or accumulator bladder (MC = 112).

The tables provide the most important data and dimensions for the following series: SB...P(H), SB16S, SBO...(P)

The part numbers provided refer to hydraulic dampers in accordance with PED (CC = U).

Designs that differ from the standard types described below can be requested from HYDAC.

4.1. TECHNICAL DATA

4.1.1 Permitted operating temperature

As standard, a hydraulic damper can be operated in the following temperature range:

-10 °C ... +80 °C

Other operating temperatures on request.

4.1.2 Permitted operating pressure

The permitted operating pressure may differ from the nominal pressure in the case of other certifications. The tables in section 4.2. show the permitted operating pressure in accordance with the European Pressure Equipment Directive.

4.1.3 Nominal volume

HYDAC hydraulic dampers are available with set nominal volumes, as described in the tables in section 4.2.

4.1.4 Effective gas volume

The effective gas volume is based on nominal dimensions. It differs slightly from the nominal volume and must be used when calculating the effective fluid volume.

For diaphragm accumulators, the effective gas volume corresponds to the nominal volume.

4.1.5 Effective volume

Volume of fluid which is available between the operating pressures p_2 and p_1 .

4.1.6 Limits for gas pre-charge pressure

Ratio of maximum operating pressure p_2 to gas pre-charge pressure p_0 .

The specified values are maximum values and must not be considered as referring to a permanent load. The sustainable pressure ratio is affected by geometry, temperature, medium, flow rate and gas losses resulting from physical characteristics.

See catalogue section:

- HYDAC Accumulator Technology
No. 3.000
- Bladder accumulators Low pressure
No. 3.202
- Bladder accumulators Standard design
No. 3.201
- Diaphragm accumulators
No. 3.100

4.2. TABLES AND DRAWINGS

4.2.1 Pulsation damper bladder accumulator

SB330/550P(PH)-..., carbon steel, NBR

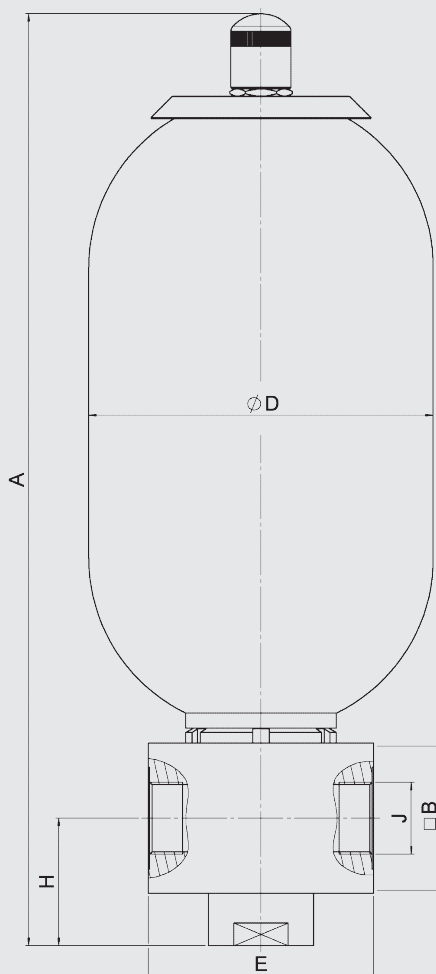

Nominal volume [l]	Series ³⁾	Max. operating pressure (PED) [bar]	Part no.	Eff. gas volume [l]	A [mm]	□ B [mm]	Ø D [mm]	E [mm]	H [mm]	J ¹⁾ Thread ISO 228	Weight [kg]
1	SB330P	330	296114	1	365	80	118	120	57	G 1 1/4	11
	SB550P	550	3435597 ³⁾		384	70	121		53		13
2.5	SB330P	330	3078967	2.4	570	80	118	120	57	G 1 1/4	16
	SB550P	550	3576155 ³⁾	2.5	589	70	121		53		20
4	SB330P	330	3121155	3.7	455	80	171	150	57	G 1 1/2	18
	SB330PH		–		491	100			85		26
5	SB550P	550	4313259 ³⁾	4.9	917	70	121	120	53	G 1 1/4	26
6	SB330P	330	3140558	5.7	559	80	171	150	57	G 1 1/2	20
	SB330PH		–		593	100			85		28
10	SB330P	330	3082257	9.3	620	130x140	229	150	100	G 1 1/2	40
	SB330PH		–		652				100	SAE 2" - 6000 psi	50
13	SB330P	330	2107871	12	712	100	229	150	85	G 1 1/2	48
20	SB330P		3084825	18.4	920	130x140			100	100	SAE 2" - 6000 psi
	SB330PH	–	952		100		85	G 1 1/2		82	
24	SB330P	330	3152980	23.6	986	100	229	150	85	G 1 1/2	100
32	SB330P		3121154	33.9	1445	130x140			100	100	SAE 2" - 6000 psi
	SB330PH	–	1475		100		SAE 2" - 6000 psi	110			

¹⁾ Standard connection code = AI, others on request

²⁾ Special/welded version, on request

³⁾ Material code (MC) = 212, see model code, section 3.

4.2.2 Pulsation damper diaphragm accumulator

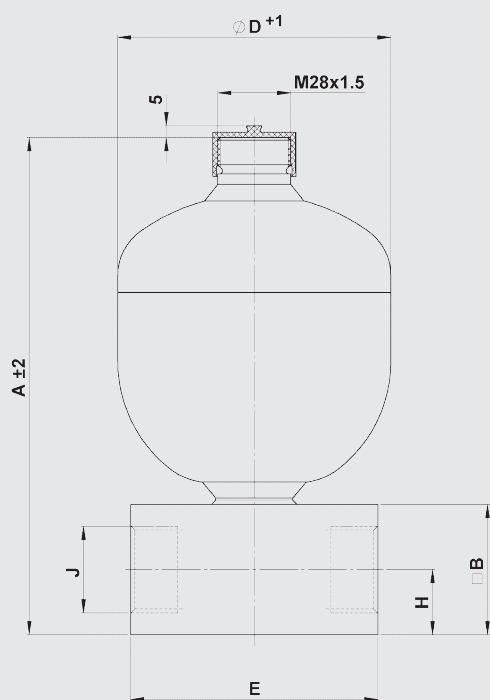

Fig. 1

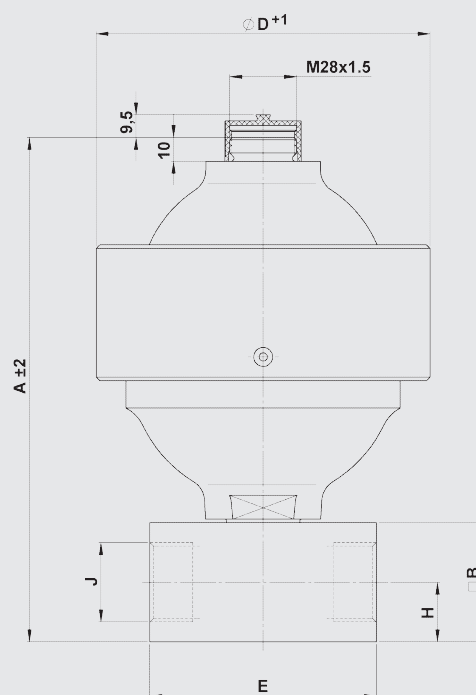

Fig. 2

Nominal volume [l]	Series and connection type ¹⁾	Max. operating pressure (PED)		A [mm]	□ B [mm]	Ø D [mm]	E [mm]	H [mm]	J Thread ISO 228	Weight [kg]	Fig.
		Carbon steel [bar]	Stainless steel [bar]								
0.075	SBO250P-...E1...AK	250	-	131	-	64	Hex 41	13	G 1/4	0.9	1
0.16	SBO210P-...E1...AK	210	180	143	-	74				1	
0.32	SBO210P-...E1...AI		160	175	50	93	80	25	G 1/2	2.6	
0.5		-	192	105						3	
0.6	SBO330P-...E1...AI	330	-	222	60	115	105	30	G 1	5.6	
0.75	SBO210P-...E1...AI	210	140	217		121				5.1	
1	SBO200P-...E1...AI	200	-	231		136				6	
1.4	SBO140P-...E1...AI	140	-	244		145				6.2	
	SBO210P-...E1...AI	210	-	250		150				7.7	
2	SBO250P-...E1...AI	250	-	255		153				8.2	
	SBO100P-...E1...AI	100	100	261		160				6.3	
2	SBO210P-...E1...AI	210	-	267		167				8.9	
	SBO250P-...E1...AI	250	-	377		170				13.5	
4	SBO50P-...E1...AI	-	50	368		158				7.9	
	SBO250P-...E1...AI	-	180	377	170	13.5					
0.25	SBO500P-...A6...AI	500	350	162	50	115 (125)	80	25	G 1/2	5.2 (6.3)	2
0.6	SBO450P-...A6...AI	450	250	202	60	140 (142)	95	30	G 1	8.9 (9.1)	
1.3	SBO400P-...A6...AI	400	-	267		199	13.8				
2	SBO250P-...A6...AI	250	180	285		201	15.6				
2.8	SBO400P-...A6...AI	400	-	308		252	24.6				
4		-	325	287		36.6					

¹⁾ Standard connection code = AK or AI, others on request

() Brackets indicate different dimensions for stainless steel version

4.2.3 Pulsation damper for aggressive media SBO...P-...A6/347...(PTFE)

Pulsation damper in stainless steel with PTFE-coated diaphragm.
Also available without connection block.

Permitted operating temperature: -15 °C ... +80 °C

Permitted pressure ratio: $p_2 : p_0 = 2 : 1$

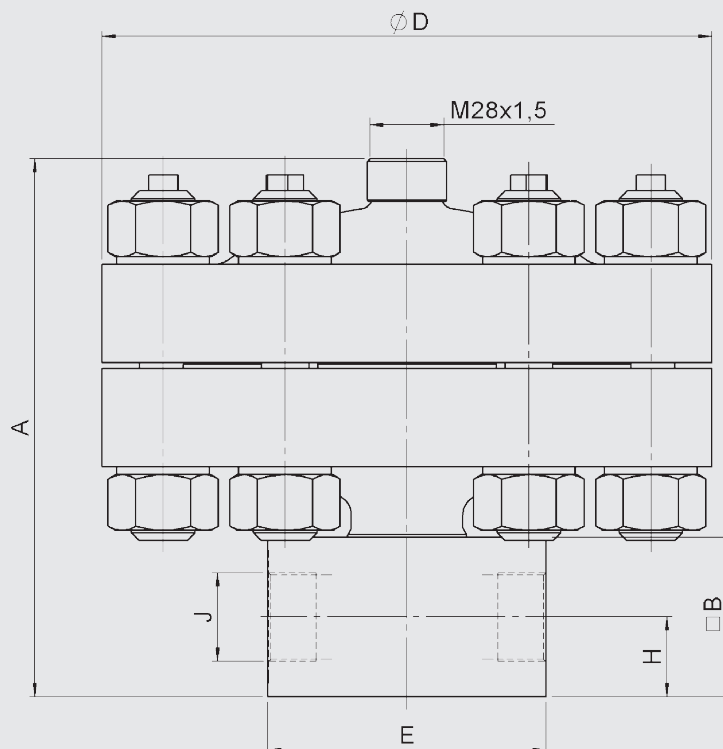

Nominal volume [l]	Max. operating pressure (PED) [bar]	Part no.	A [mm]	□ B [mm]	Ø D [mm]	E [mm]	H [mm]	J ¹⁾ Thread	Weight [kg]		
0.2	40	4328332	140	60	210	105	30	ISO 228	11		
	250	4328333	197		230						
0.5	40	3091224	165		210					G 1	12
	250	3091221	200		230						

¹⁾ Standard connection code = AI, others on request

SBO...(P)-...A4/777... (PVDF/PTFE)

Pulsation damper in PVDF with PTFE-coated diaphragm.

Permitted operating temperature: -10 °C ... +65 °C

Permitted pressure ratio: $p_2 : p_0 = 2 : 1$

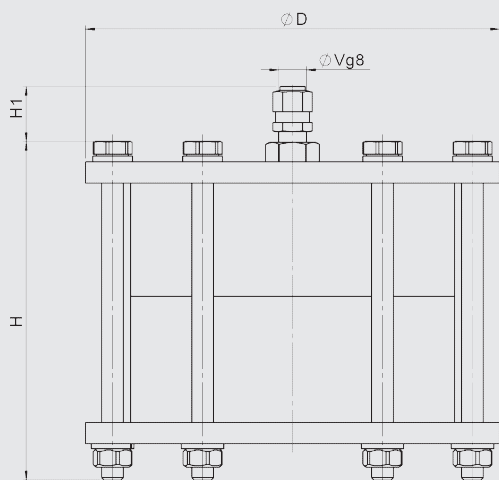

Fig. 1

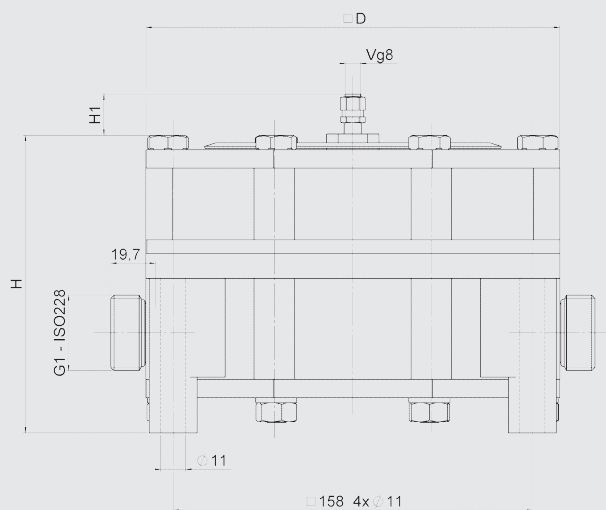
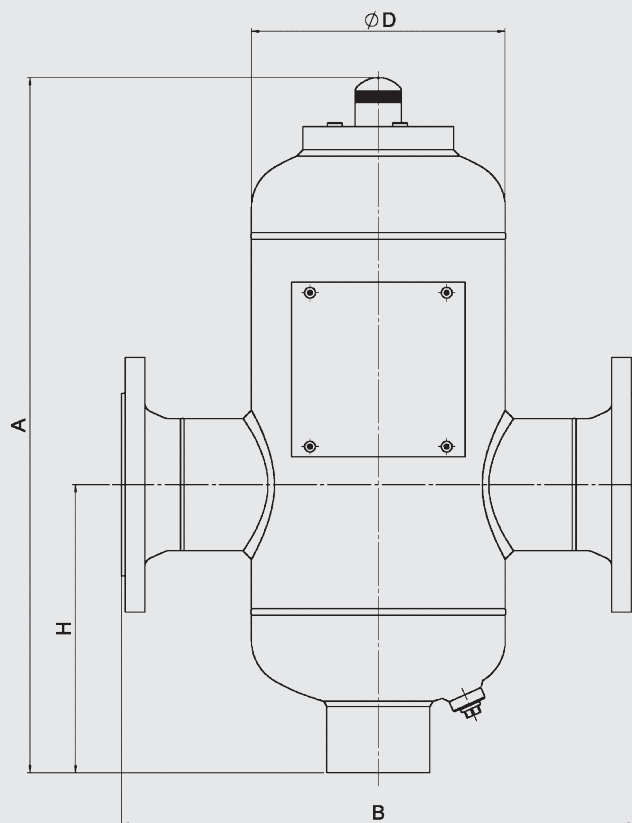

Fig. 2

Nominal volume [l]	Max. operating pressure (PED) [bar]	Part no.	Ø/□ D [mm]	H [mm]	H1 [mm]	Weight [kg]	Figure
0.08	12	3655864	115	94	15	1.5	1
0.2	10	—	182	128	20	5.7	2
	16	—		130	18	6.4	
	25	3357658		168	20	6	
0.5	10	—		170	19	6.8	
	16	—					
	25	3357657					

Suction flow stabiliser SB16S



Nominal volume	Fluid volume	Perm. operating pressure (PED)	Eff. gas volume	A	B	Ø D	H	DN ¹⁾	Weight
[l]	[l]	[bar]	[l]	[mm]	[mm]	[mm]	[mm]		[kg]
12	12	16	1	580	425	219	220	65	40
25	25		2.5	1025					60
40	40		4	890	540	300	250	80	85
100	100		10	1150	650	406	350	100	140
400	400		35	2050	870	559	400	125	380

Further pressure ratings 25 bar, 40 bar; others on request

Other fluid volumes on request

¹⁾ To EN1092-1/11 /B1/PN16

4.3. SPARE PARTS

4.3.1 Pulsation damper bladder accumulator SB330/550P(PH)

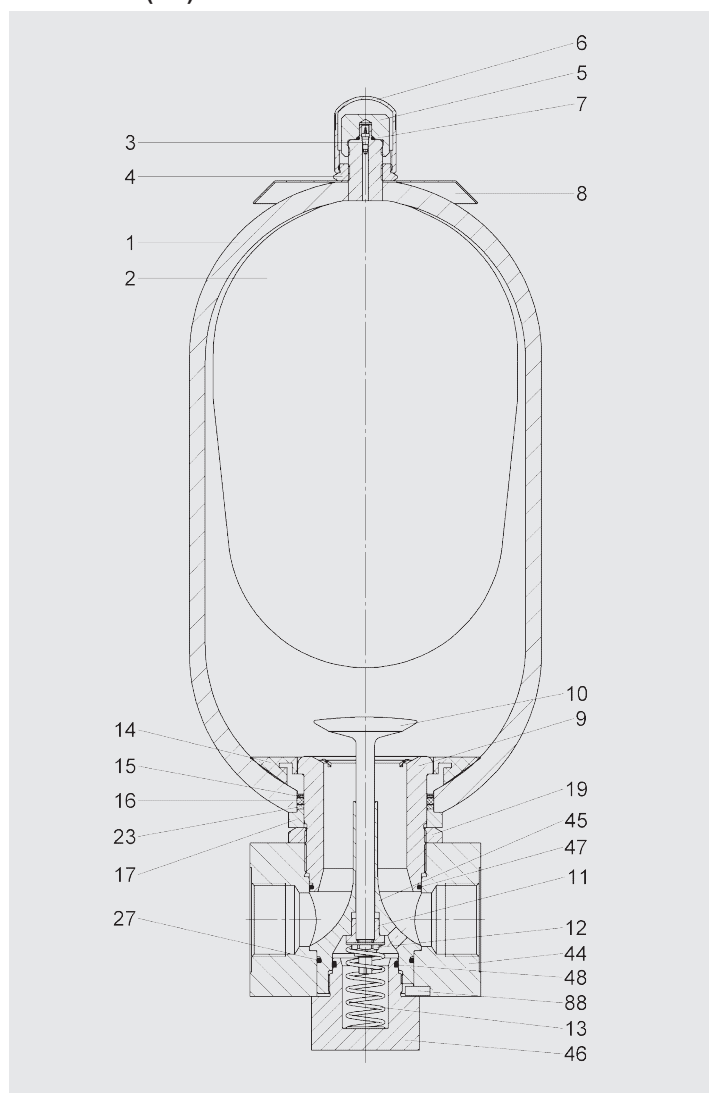

Description	Item
Bladder assembly	
consisting of:	
Bladder	2
Gas valve insert ¹⁾	3
Lock nut	4
Seal cap	5
Protective cap	6
O-ring	7
Seal kit	
consisting of:	
O-ring	7
Washer	15
O-ring	16
Support ring	23
O-ring	27
O-ring	47
O-ring	48

¹⁾ Available separately

Accumulator shell (item 1) and company label (item 8) not available as spare part

Description	Item
Connection assembly	
consisting of:	
Oil valve body	9
Valve plate	10
Damping bush	11
Lock nut	12
Valve spring	13
Anti-extrusion ring ¹⁾	14
Washer	15
O-ring	16
Spacer	17
Groove nut	19
Support ring (only for 330 bar)	23
O-ring	27
Connector	44
Guide piece	45
Cap	46
O-ring	47
O-ring	48
Locking key	88

¹⁾ Available separately

NBR, carbon steel, standard gas valve

Nominal volume [l]	Bladder assembly	Seal kit	
		SB330P/SB400P	SB550P
1	237624	357055	2106402
2.5	236171		
4	236046		
5	240917		
6	2112097		
10	236088	357058	357061
13	376249		
20	236089		
24	376253		
32	235335		

4.3.2 Pulsation damper diaphragm accumulator SBO...P...E

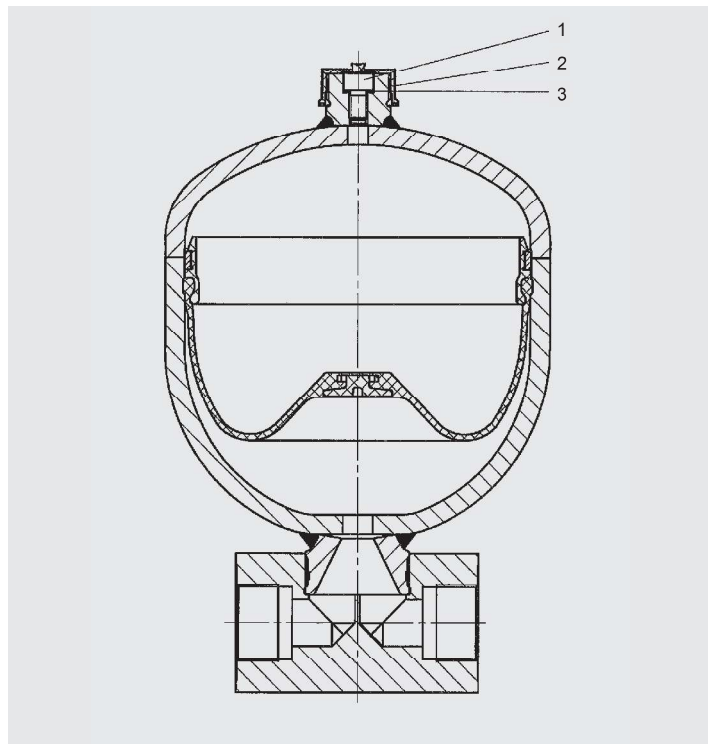

Description	Item
Spare parts set, gas side	
consisting of:	
Locking screw	1
Protective cap	2
Seal ring	3

Nominal volume [l]	Part no.				
	NBR	ECO	FKM	IIR	PTFE
Spare parts set for gas side					
0.075 - 4	3262845	-	-	-	-

SBO...P...A6

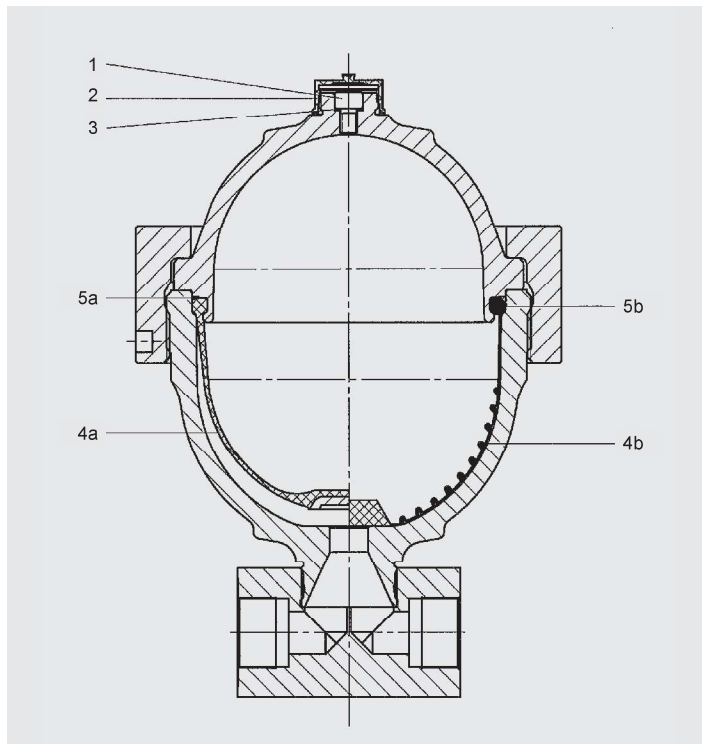

Description	Qty.	Item
Spare parts set, gas side		
consisting of:		
Locking screw	20	1
Protective cap	20	2
Seal ring	20	3

Spare parts kit with elastomer diaphragm	
consisting of:	
Locking screw	1
Seal ring	3
Elastomer diaphragm	4a
Support ring	5a

Spare parts kit with full-PTFE diaphragm	
consisting of:	
Locking screw	1
Seal ring	3
Full-PTFE diaphragm	4b
O-ring	5b

Nominal volume [l]	Part no.				
	NBR	ECO	FKM	IIR	PTFE
Spare parts set for gas side					
0.075 - 4	3262845	-	-	-	-
Spare parts kit					
0.1	3042668	3182526	-	-	-
0.25	3042709	3042712	3042714	3042713	3504798
0.6	3042710	3042715	3042717	3042716	3550388
1.3	3042681	3042682	3042684	-	3446897
2	3042711	3042719	3042721	3042720	3464205
2.8	3042700	3042701	3042704	3042702	-
4	3042705	3042706	3042708	3042707	-

4.3.3 Pulsation dampers for aggressive media SBO...P-...A6/347...(PTFE)

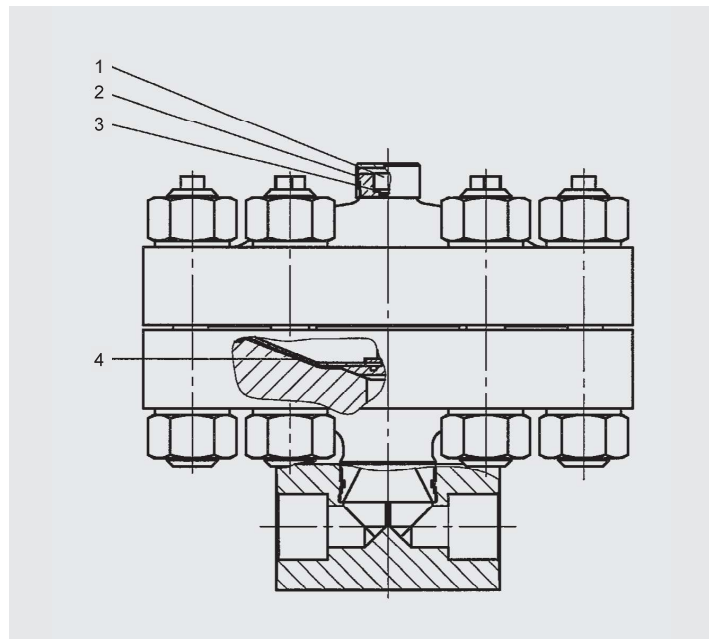

Description	Item
-------------	------

Spare parts kit, gas side consisting of:

Locking screw	1
Seal ring	3
Diaphragm	4

Designation	Part no.
Spare parts kit for gas side	3196168

Protective cap (item) on request

SBO...(P)-...A4/777... (PVDF/PTFE)

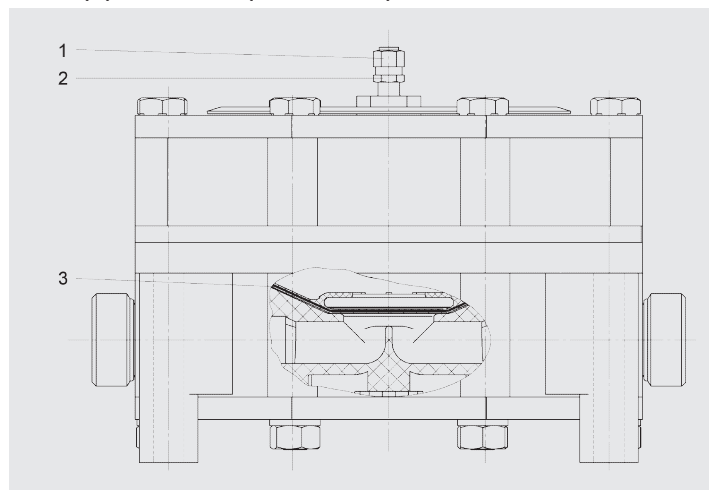

Description	Item
Gas valve assembly	1
Gas valve insert brass/stainless steel	2
Diaphragm	3

Designation	Material	Part no.
Gas valve assembly	Stainless steel 1.4571 FPM / PTFE / brass	3320800
Gas valve insert	FPM / PTFE / brass FPM / PTFE / stainless steel 1.4571	629516 632992
Diaphragm	PTFE / NBR	3279342

4.3.4 Suction flow stabiliser

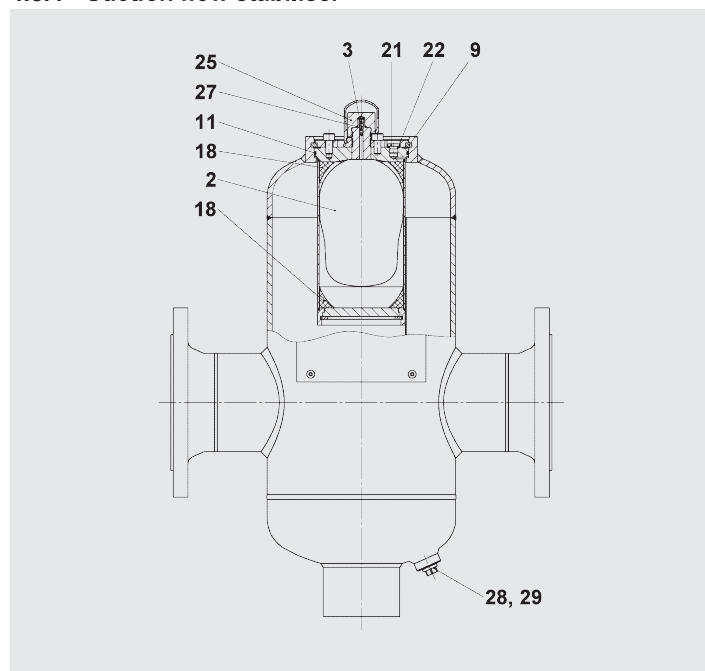

Description	Item
-------------	------

Accumulator bladder	2
Gas valve insert	3
Anti-extrusion ring	9
O-ring	11
Insertion ring, 2x	18
Locking screw	21
Seal ring	22
Seal cap	25
O-ring	27
Seal ring	28
Locking screw	29

5. NOTE

The information in this brochure relates to the operating conditions and fields of application described. For applications and/or operating conditions not described, please contact the relevant technical department.
Subject to technical modifications.

HYDAC Technology GmbH
Industriegebiet
66280 Sulzbach/Saar, Germany
Tel.: +49 68 97 / 509 - 01
Internet: www.hydac.com
E-mail: speichertechnik@hydac.com