



## Metal bellows accumulators

### 1. DESCRIPTION

#### 1.1. FUNCTION

While fluids are practically incompressible, this does not apply to gases. Hydraulic accumulators use these basic laws of physics to store hydraulic energy. Nitrogen is normally used as the compressible medium.

The various types of hydraulic accumulator are categorised on the basis of the separation element that keeps the gas section separate from the fluid section in the pressure vessel. In the case of metal bellows accumulators, this is a metallic corrugated or diaphragm bellows.

The fluid section is connected to the hydraulic circuit so that the metal bellows accumulator draws in fluid when the pressure increases and the gas is compressed. When the system pressure drops, the compressed gas expands and forces the stored fluid back out into the hydraulic circuit.

HYDAC metal bellows accumulators are made with tailor-made designs and material selections. Because of their special properties, they are an outstanding addition to the HYDAC hydraulic accumulator product range.

Some examples are provided on the following pages and in our flyer

- Large engines – metal bellows accumulators  
No. 10.129.1



We are always happy to provide detailed advice.

## 1.2. DESIGN

HYDAC metal bellows accumulators are available as a standard series, see section 4.

Depending on customer requirements and the field of application, the metal bellows accumulator can be individually tailored in terms of the bellows design and the accumulator geometry.

The following diagram illustrates an example of the structure of a metal bellows accumulator with convoluted bellows, configured for a damping application:

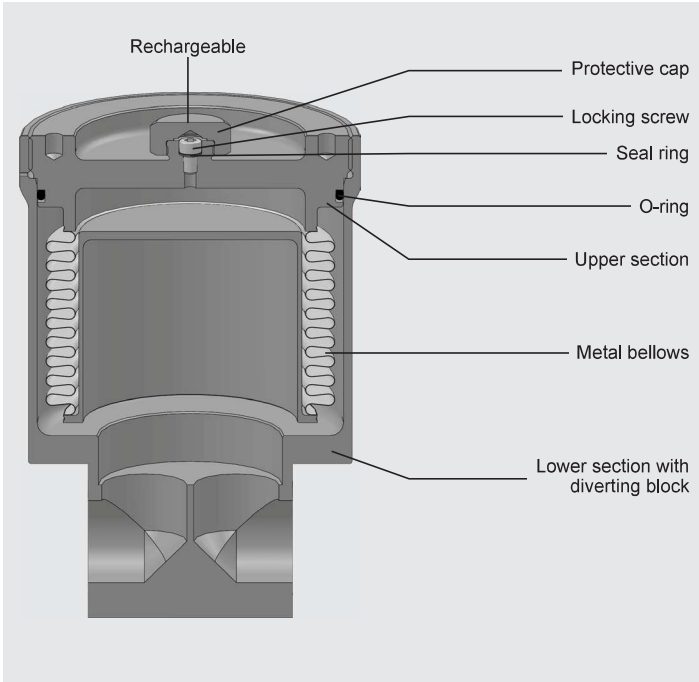

### 1.2.1 Bellows design

HYDAC supplies two types of metal bellows:

#### ■ Corrugated bellows (formed)

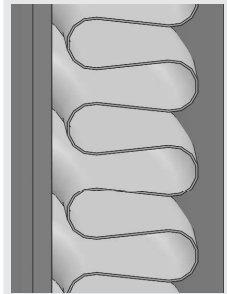

- Suitable for high differential pressures
- Unsusceptible to contamination
- Robust

#### ■ Diaphragm bellows (welded)

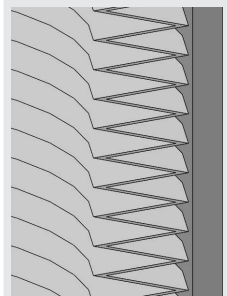

- High displacement volumes
- Very good energy storage properties
- Compact design

### 1.2.2 Pressure vessel

The pressure vessel of the metal bellows accumulator fundamentally comprises of an upper section and a lower section. These can be connected in a wide variety of ways.

The most common variants are listed below. Others are available on request.

#### Screw type



#### Weld type

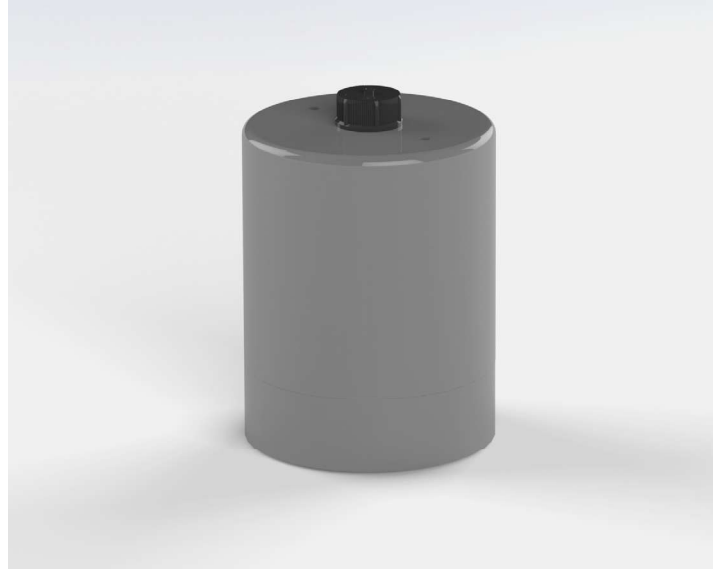

#### Formed type



## 2. GENERAL INFORMATION

### 2.1. MATERIALS, CORROSION PROTECTION

#### 2.1.1 Accumulator shell

The pressure vessel is fabricated in carbon steel or in stainless steel. Various coating systems are available to protect carbon steel versions.

#### 2.1.2 Metal bellows

The metal bellows are made from stainless steel.

#### 2.1.3 Sealing system

NBR, FKM, etc.

### 2.2. INSTALLATION POSITION

Metal bellows accumulators are preferably to be installed vertically, with the gas charging connection at the top. Other installation positions must be agreed with HYDAC.

### 2.3. TYPE OF INSTALLATION

HYDAC mounting elements must be used to securely fasten metal bellows accumulators.

### 2.4. CHARGING GAS

- Charging gas: Nitrogen
- Specification: min. Class 2.8

If other gases are to be used or if these specifications are deviated from, please contact HYDAC.

### 2.5. HYDRAULIC FLUID

Diaphragm bellows accumulators must only be operated with hydraulic fluids that contain no hard particles and that have a minimum cleanliness class of:

- NAS 1638 Class 6 or
- ISO 4406 Class 17/15/12

Furthermore, the fluid must not solidify at any time.

### 2.6. CERTIFICATES

Hydraulic accumulators that are installed outside of Germany are supplied with the relevant test certificate documentation. The country of installation must be stated at the time of ordering. HYDAC pressure vessels can be supplied with almost any approval classification. The permitted operating pressure may differ from the nominal pressure.

The following table provides some examples of the code in the model code:

Country	Certificate code (CC)
EU member states	U
Australia	F <sup>1)</sup>
Belarus	A6
Canada	S1 <sup>1)</sup>
China	A9
Great Britain	Y
Hong Kong	A9
Iceland	U
Japan	P
Korea (Republic of)	A11
New Zealand	T
Norway	U
Russia	A6
South Africa	S2
Switzerland	U
Turkey	U
Ukraine	A10
USA	S

<sup>1)</sup> Registration required in the individual territories or provinces.

Others on request

## 2.7. FURTHER INFORMATION

- Operating instructions for metal bellows accumulators No. 3.304.BA

### The operating instructions and the product-specific documents must be observed!

All work on HYDAC metal bellows accumulators must only be carried out by suitably trained staff. Incorrect installation or handling can lead to serious accidents.

- Assembly and repair instructions for metal bellows accumulators No. 3.304.M

For repairs to be performed on hydraulic accumulators, we provide corresponding assembly and repair instructions.

Further information such as accumulator sizing, safety information and extracts from the acceptance specifications can be found in our overview catalogue section:

- HYDAC Accumulator Technology No. 3.000

This document and others are available from our Download Center at [www.hydac.com](http://www.hydac.com).

### 3. MODEL CODE

Not all combinations are possible. Order example.  
For further information, please contact HYDAC.

**SM50 P - 0,5 W E 1/ 116 U - 50 AAJ - 2,5**

#### Series

#### Type code

No details = without diverting block  
P = with diverting block  
L = light-weight

#### Nominal volume [l]

#### Version

W = corrugated bellows  
M = diaphragm bellows

#### Type of shell

A = screw type  
E = weld type  
G = formed type

#### Gas side connection

1 = gas pressure adjustable (M28x1.5)  
2 = gas pressure pre-set, non-adjustable gas locking screw  
3 = gas pressure adjustable (M16x1.5)

#### Material code (MC)

#### Fluid port

1 = carbon steel  
2 = carbon steel with corrosion protection  
3 = stainless steel <sup>1)</sup>

#### Accumulator shell

1 = carbon steel  
2 = carbon steel with corrosion protection  
4 = stainless steel <sup>1)</sup>

#### Seal material

0 = no seal  
2 = NBR  
6 = FKM  
7 = other materials  
9 = FFKM

#### Certification code

U = European Pressure Equipment Directive (PED)  
For others, see section 2.6.

#### Permitted operating pressure [bar]

#### Fluid port

See tables in catalogue section Piston accumulators, Standard design, No. 3.301

**Pre-charge pressure  $p_0$  [bar] at 20 °C, must be stated clearly, if required!**

<sup>1)</sup> Dependent on type and pressure rating

## 4. STANDARD ITEMS

### 4.1. TECHNICAL DATA

The metal bellows accumulators described below are manufactured in stainless steel with a diaphragm bellows (MC = 340).

The table provides the most important data and dimensions for the following series: SM40/210

The data provided refers to metal bellows accumulators in accordance with PED (CC = U) and are guideline values for which specific part numbers can be provided on request.

#### 4.1.1 Permitted operating temperature

As standard, a metal bellows accumulator can be operated in the following temperature range:

-40 °C ... +120 °C

Other operating temperatures on request.

#### 4.1.2 Permitted operating pressure

The permitted operating pressure may differ from the nominal pressure in the case of other certifications. The table in section 4.2. shows the permitted operating pressure in accordance with the European Pressure Equipment Directive.

#### 4.1.3 Nominal volume

HYDAC metal bellows accumulators are available with set nominal volumes, as described in the table in section 4.2.

#### 4.1.4 Displacement volume

Max. volume (fluid side) between operating pressures  $p_2$  and  $p_1$ .

### 4.2. TABLES AND DRAWINGS

Nominal volume	Rechargeable (E1)	Non-rechargeable (E2)
≤ 0.38 l		
> 0.38 l		

Nominal volume <sup>1)</sup> [l]	Max. displacement volume [l]	Series	Perm. operating pressure <sup>2)</sup> [bar]	L <sup>3)</sup> [mm]	Ø D <sup>3)</sup> [mm]	Approx weight. <sup>3)</sup> [kg]	J ISO 228
0.17	0.1	40	40	94	69	1.4	G 1/2
		210	210	96	75	1.9	
0.38	0.25	40	40	119	86	2.3	G 1/2
		210	210	127	94	3.8	
0.73	0.5	40	40	140	106	3.7	G 1/2
		210	210	155	118	7.3	
1	0.75	40	40	131	131	5.2	G 3/4
		210	210	155	145	11.5	
1.3	1	40	40	128	156	8.1	G 3/4
		210	210	157	174	18.3	
2.6	2	40	40	213	156	10.2	G 3/4
		210	210	242	174	23.6	
3.8	3	40	40	181	228	19.7	G 1 1/2
6.5	5	40	40	177	330	50.3	G 1 1/2

<sup>1)</sup> Higher nominal volume possible with same displacement volume

<sup>2)</sup> At -40 °C to max. +120 °C

<sup>3)</sup> Guidelines for dimensioning the pressure vessel at max. +120 °C

## 5. FUNCTION AND APPLICATION EXAMPLES

### 5.1. ENERGY STORAGE

The stored hydraulic energy is available from the accumulator for the following purposes: reserve pump capacity (emergency function, pump support) and leakage compensation.

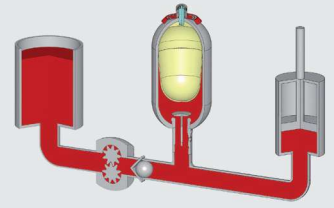

#### Application examples in the aviation industry



**Application**  
Supporting the working hydraulics for flight control



**Accumulator type**  
SM209  
**Nominal volume**  
Up to 0.4 litres  
**Material**  
Stainless steel  
**Version**  
Diaphragm bellows

### 5.2. PULSATION DAMPING

Pressure pulsations are smoothed by the compressible gas inside the accumulator, e.g. suction flow stabilisation, reduction in noise level and vibrations.

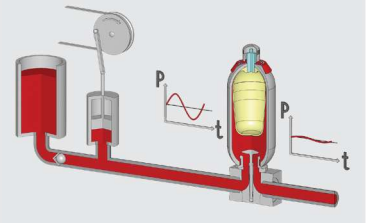

#### Application examples in large diesel engines



**Application**  
Pulsation damping  
Fuel system  
Large diesel engines



**Accumulator type**  
SM50P and SM50  
**Nominal volume**  
3.8 and 1.6 litres  
**Material**  
Carbon steel, coated  
**Version**  
Corrugated bellows

#### Application examples in the aviation industry

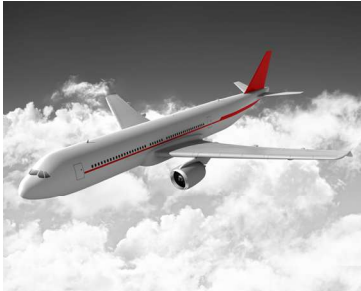

**Application**  
Suction flow stabiliser  
Hydraulic line  
Engine supply



**Accumulator type**  
SM16  
**Nominal volume**  
1 litre  
**Material**  
Stainless steel  
**Version**  
Diaphragm bellows  
**Special feature**  
Visual condition check

#### Application examples in the chemical industry/process technology

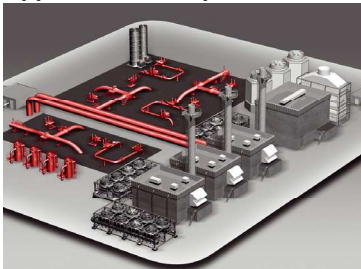

**Application**  
Suction flow stabiliser  
3-piston pump



**Accumulator type**  
SM210  
**Nominal volume**  
2 litres  
**Material**  
Stainless steel  
**Version**  
Diaphragm bellows  
**Special feature**  
Flange connection

## 5.3. VOLUME COMPENSATION

The hydraulic accumulator compensates for surplus volume, for instance when the volume of the fluid increases due to an increase in temperature.

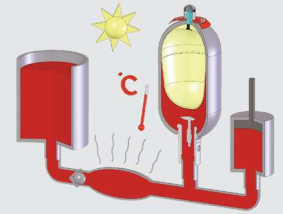

### Application examples in the chemical industry/process technology



**Application**  
Volume compensation when temperature fluctuates



**Accumulator type**  
SM16  
**Nominal volume**  
1 litre  
**Material**  
Stainless steel  
**Version**  
Diaphragm bellows



**Accumulator type**  
SM16  
**Nominal volume**  
9.4 litres  
**Material**  
Stainless steel  
**Version**  
Diaphragm bellows  
**Special feature**  
High displacement volume  
Compact bellows design

## 6. NOTE

The information in this brochure relates to the operating conditions and fields of application described. For applications and/or operating conditions not described, please contact the relevant technical department. Subject to technical modifications.

**HYDAC Technology GmbH**  
Industriegebiet  
**66280 Sulzbach/Saar, Germany**  
Tel.: +49 68 97 / 509 - 01  
Internet: [www.hydac.com](http://www.hydac.com)  
E-mail: [speichertechnik@hydac.com](mailto:speichertechnik@hydac.com)

