



## Piston accumulators Standard design

### 1. DESCRIPTION

#### 1.1. FUNCTION

While fluids are practically incompressible, this does not apply to gases. Hydraulic accumulators use these basic laws of physics to store hydraulic energy. Nitrogen is normally used as the compressible medium.

The various types of hydraulic accumulator are categorised on the basis of the separation element that keeps the gas section separate from the fluid section in the pressure vessel. In the case of the piston accumulator, this is a piston made from aluminium or steel with a sealing system that is compatible with the application.

The fluid side of the piston accumulator is connected to the hydraulic circuit so that the piston accumulator draws in fluid when the system pressure increases and the trapped gas is compressed. When the system pressure drops, the compressed gas expands and forces the stored fluid back out into the hydraulic circuit.

HYDAC piston accumulators are available in various designs, see catalogue sections:

- Piston accumulators SK280  
No. 3.303



- Piston accumulators High pressure  
No. 3.302



## 1.2. DESIGN

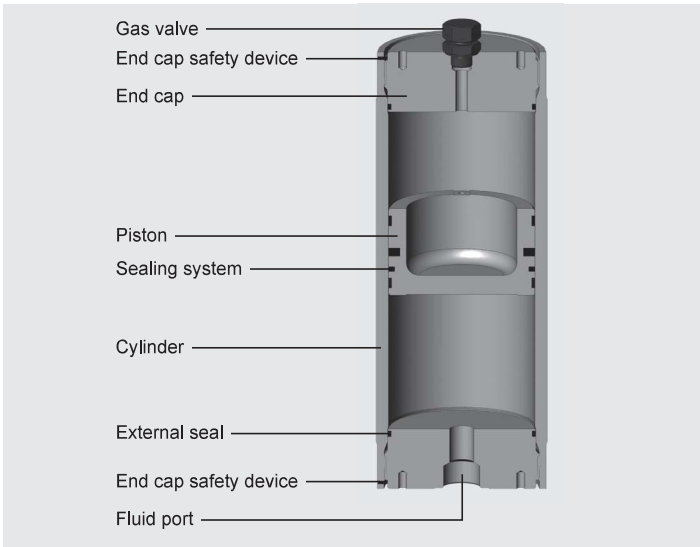

HYDAC piston accumulators consist of the following key individual components:

- Cylinder with a very finely machined internal surface
- Gas side end cap and oil side end cap, both sealed with O-rings
- Steel or aluminium piston
- Sealing system adapted to the particular field of application

The piston floats on guide rings which prevent metal-to-metal contact between the piston and the accumulator wall. Suitable materials are available for low temperature applications.

### 1.2.1 Piston design

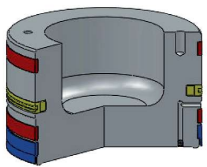
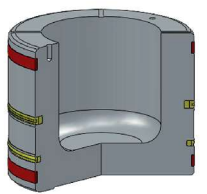
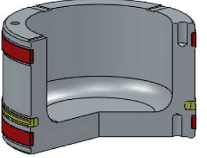
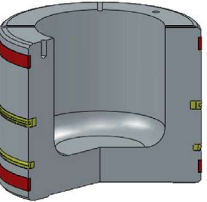
Design	Application	Contamination level of fluid	Comment
	1 – For general accumulator operation with without special requirements  <u>Application limitations:</u> max. piston velocity: 0.5 m/s	Optimised for applications with a high level of contamination	
	2 – Low-friction design – For high piston speeds – Depending on fluid, slow movements without stick-slip effect  <u>Application limitations:</u> Max. piston velocity: 3.5 m/s		
	3 – Low-friction design – Simple-to-fit seals – Depending on fluid, slow movements without stick-slip effect  <u>Application limitation:</u> Max. piston velocity: 0.8 m/s	Filtration: NAS 1638 - Class 6 ISO 4406 - Class 17/15/12	1 guide ring for pistons with $\varnothing \leq 150$ mm  2 guide rings for pistons with $\varnothing \geq 180$ mm
	4 – Low-friction design with emergency safety features – Depending on fluid, slow movements without stick-slip effect – Very low oil transfer to the gas side  <u>Application limitations:</u> Max. piston velocity: 5 m/s		

## 2. GENERAL INFORMATION

### 2.1. MATERIALS, CORROSION PROTECTION

#### 2.1.1 Accumulator shell

The cylinder and the two end caps are manufactured in carbon steel as standard. For use with certain aggressive or corrosive fluids, the parts coming into contact with the fluid can be nickel plated for protection, or made entirely from corrosion-resistant material. When supplied piston accumulators are suitable for short-term storage. Piston accumulators suitable for long-term storage are available on request.

#### 2.1.2 Pistons with a sealing system

Precise information about the intended operating conditions is required in order to select the most appropriate sealing system for the field of application.

Important criteria for this selection are, for example, the:

- Design pressure
- Actual pressure differential
- Switching frequency or switching cycle
- Piston velocity
- Operating temperature
- Operating fluid
- Cleanliness of fluid (filtration rating)
- Maintenance requirements

The sealing systems differ according to the type of piston used, each of which has its own type and arrangement of seals. Various elastomers are available as a sealing material, depending on the operating conditions, see section 2.1.3

#### 2.1.3 Maximum temperature range of elastomer materials

The permitted working temperature of a piston accumulator is dependent on the application limits of the metal materials and the piston seal. The operating medium must also be taken into account.

The following table shows the main **elastomer materials with their maximum possible temperature ranges** with examples of operating fluids.

Materials		Material code <sup>1)</sup>	Max. possible temperature range <sup>2)</sup>	Possible operating fluids, others on request	
				Resistant to	Not resistant to
NBR	Acrylonitrile butadiene rubber	2	-20 °C ... + 80 °C	<ul style="list-style-type: none"> <li>- Mineral oil (HL, HLP)</li> <li>- Flame-retardant fluids from the groups HFA, HFB, HFC</li> <li>- Synthetic esters (HEES)</li> <li>- Water</li> <li>- Sea water</li> </ul>	<ul style="list-style-type: none"> <li>- Aromatic hydrocarbons</li> <li>- Chlorinated hydrocarbons (HFD-S)</li> <li>- Amines and ketones</li> <li>- Hydraulic fluids from the group HFD-R</li> <li>- Fuels</li> </ul>
		5	-40 °C ... + 80 °C		
PUR	Polyurethane	8	Standard application -30 °C ... + 80 °C	<ul style="list-style-type: none"> <li>- Mineral oil (HL, HLP)</li> <li>- Flame-retardant fluids from the HFA group</li> </ul>	<ul style="list-style-type: none"> <li>- Water and water-glycol mixture</li> <li>- HFC</li> <li>- Alkalis</li> <li>- Acids</li> </ul>
			Special application -40 °C ... +100 °C		
FKM	Fluorine rubber	6	-15 °C ... +160 °C	<ul style="list-style-type: none"> <li>- Mineral oil (HL, HLP)</li> <li>- Hydraulic fluids from the group HFD</li> <li>- Synthetic esters (HEES)</li> <li>- Fuels</li> <li>- Aromatic hydrocarbons</li> <li>- Inorganic acids</li> </ul>	<ul style="list-style-type: none"> <li>- Amines and ketones</li> <li>- Ammonia</li> <li>- Skydrol and HyJet IV</li> <li>- Steam</li> </ul>

<sup>1)</sup> The material code (MC) is described in more detail in the model code, see section 3.

<sup>2)</sup> The specified temperature range relates to the particular elastomer material, not to the operating range of the hydraulic accumulator, see section 4.1.1

## 2.2. INSTALLATION POSITION

HYDAC piston accumulators operate in any position. Vertical installation is preferable with the gas side at the top, to prevent contaminant particles from the fluid settling on the piston seals. For hydraulic accumulators with certain piston position indicators, vertical installation is essential.

## 2.3. TYPE OF INSTALLATION

For strong vibrations and volumes above 1 litre, we recommend the use of two HYDAC mounting clamps, or more as appropriate, ideally in the end cap area. See catalogue section:

- Mounting elements for hydraulic accumulators No. 3.502

## 2.4. CHARGING GAS

- Charging gas: Nitrogen
- Specification: min. Class 2.8

If other gases are to be used or if these specifications are deviated from, please contact HYDAC.

## 2.5. HYDRAULIC FLUID

Hydraulic accumulators must only be operated with operating fluids with a minimum cleanliness class of:

- NAS 1638 Class 6 or
- ISO 4406 Class 17/15/12

## 2.6. CERTIFICATES

Hydraulic accumulators that are installed outside of Germany are supplied with the relevant test certificate documentation. The country of installation must be stated at the time of ordering. HYDAC pressure vessels can be supplied with almost any approval classification. The permitted operating pressure may differ from the nominal pressure.

The following table provides some examples of the code in the model code:

Country	Certificate code (CC)
EU member states	U
Australia	F <sup>1)</sup>
Belarus	A6
Canada	S1 <sup>1)</sup>
China	A9
Great Britain	Y
Hong Kong	A9
Iceland	U
Japan	P
Korea (Republic of)	A11
New Zealand	T
Norway	U
Russia	A6
South Africa	S2
Switzerland	U
Turkey	U
Ukraine	A10
USA	S

<sup>1)</sup> Registration required in the individual territories or provinces.

Others on request

## 2.7. EFFECT OF SEALING FRICTION

The permitted piston velocity depends on the sealing friction. Higher piston velocities are possible where there is less sealing friction.

HYDAC piston accumulators of piston design 2 allow velocities of up to 3.5 m/s.

## 2.8. PERMITTED VELOCITIES

### Gas velocity

The flow velocities in the gas side connection and pipe system should be limited to 30 m/s when using piston accumulators of the back-up type. Gas velocities of over 50 m/s should be avoided at all costs.

### Oil velocity

In order to limit the pressure losses when the operating fluid is displaced, the flow velocity should not exceed 10 m/s in the fitting cross-section.

## 2.9. FUNCTION TESTS AND FATIGUE TESTS

Function tests and fatigue tests are carried out to ensure continuous improvement of our piston accumulators.

By subjecting the accumulators to endurance tests under realistic as well as extreme working conditions, important data can be obtained about the long-term behaviour of the component. In the case of piston accumulators, important information on gas density and the service life of seals is gained from such tests.

Vital data for use in accumulator sizing is gained by altering the working pressure and switching cycles.

## 2.10. FURTHER INFORMATION

- Operating instructions for piston accumulators No. 3.301.BA

### The operating instructions must be observed!

All work on HYDAC piston accumulators must only be carried out by suitably trained staff. Incorrect installation or handling can lead to serious accidents.

- Assembly and repair instructions piston accumulators No. 3.301.M

For repairs to be performed on hydraulic accumulators, we provide corresponding assembly and repair instructions.

Further information such as accumulator sizing, safety information and extracts from the acceptance specifications can be found in our overview catalogue section:

- HYDAC Accumulator Technology No. 3.000

This document and others are available from our Download Center at [www.hydac.com](http://www.hydac.com).

### 3. MODEL CODE

Not all combinations are possible. Order example.  
For further information, please contact HYDAC.

SK350 - 20 / 2212 U - 350 AAG - VA - 18 A - 1 - 050

#### Series

#### Nominal volume [l]

#### Material and piston code (MC)

Dependent on operating fluid  
Standard design = 2212 for mineral oil  
Others on request

#### Piston design (see section 1.2.1)

#### Piston material

- 1 = aluminium
- 2 = carbon steel
- 3 = stainless steel <sup>1)</sup>

#### Material of cylinder and end cap

- 1 = carbon steel
- 2 = carbon steel with surface protection
- 3 = stainless steel <sup>1)</sup>
- 6 = carbon steel (low temperature)

#### Material of sealing system, including piston seal

- 2 = NBR <sup>2)</sup> / PTFE compound
- 5 = NBR <sup>2)</sup> / PTFE compound
- 6 = FKM / PTFE compound
- 8 = NBR <sup>2)</sup> / PUR
- 9 = special qualities

#### Certification code

U = European Pressure Equipment Directive (PED)  
For others, see section 2.6.

#### Permitted operating pressure [bar]

#### Fluid port

Type of connection (see Table 1)  
Standard or specification of the type of connection (see Tables 2 + 3)  
Size of connection (see Tables 4 + 5)

#### Gas-side connection or gas valve

Type of connection (see Table 1)  
Standard or specification of the type of connection (see Tables 2 + 3)  
(no letter required for connection type V)  
Size of connection (see Table 4, 5 + 6)

#### Piston diameter

- |             |             |
|-------------|-------------|
| 04 = 40 mm  | 20 = 200 mm |
| 05 = 50 mm  | 25 = 250 mm |
| 06 = 60 mm  | 31 = 310 mm |
| 08 = 80 mm  | 35 = 355 mm |
| 10 = 100 mm | 49 = 490 mm |
| 12 = 125 mm | 54 = 540 mm |
| 15 = 150 mm | 61 = 610 mm |
| 18 = 180 mm |             |

#### Additional equipment <sup>3)</sup>

Detailed technical data on request,  
see flyer "Monitoring equipment for hydraulic accumulators", No. 3.506

- A = electrical limit switch – 35 mm stroke
- B = electrical limit switch – 200 mm stroke
- C = electrical limit switch – 500 mm stroke
- E.. = other electrical limit switch, fixed or adjustable
- K = protruding piston rod
- L = linear position measurement system
- LA = laser linear position measurement system
- M = magnetic flap indication
- S = cable tension measurement system
- UP.. = piston position switch (e.g. UP2 = 2 position switches)
- W = limit switch with linear position measurement system

#### Safety equipment <sup>3)</sup>

- 1 = burst disc (please give nominal pressure and temperature)
- 2 = gas safety valve
- 3 = temperature fuse

**Pre-charge pressure  $p_0$  [bar] at 20 °C, must be stated clearly, if required!**

<sup>1)</sup> Dependent on type and pressure rating  
<sup>2)</sup> Observe temperature ranges, see section 2.1.3  
<sup>3)</sup> If required, please state at time of ordering

**Table 1, Connection type**

Code letter	Description
A	Threaded connection (internal thread)
B	Threaded connection (external thread)
F	Flange connection
H	Protruding flange
K, S	Combination connection / special connection
V	Gas valve type

**Table 2, Threaded connection: standard or specification**

Code letter	Description
A	Thread to ISO 228 (BSP)
B	Thread to DIN 13 or ISO 965/1 (metric)
C	Thread to ANSI B1.1 (UN.-2B, seal SAE J 514)
D	Thread to ANSI B1.20.3 (NPTF)

**Table 3, Flange connection: standard or specification**

Code letter	Description
A	Flanges to DIN standards (pressure rating + standard)
B	Flanges to ANSI B 16.5
C	SAE flange 3000 psi
D	SAE flange 6000 psi
E	High pressure block flange (Bosch-Rexroth) PN320
F	High pressure block flange (AVIT, HAVIT) PN320

**Table 4, Threaded version: connection sizes**

Type listed in Table 2	Code letter, size										
	A	B	C	D	E	F	G	H	J	K	L
A	G 1/8	G 1/4	G 3/8	G 1/2	G 3/4	G 1	G 1 1/4	G 1 1/2	G 2	G 2 1/2	G 3
B	M10x1	M12x1.5	M14x1.5	M16x1.5	M18x1.5	M22x1.5	M27x2	M33x2	M42x2	M48x2	M60x2
C	5/16-24UNF	3/8-24UNF	7/16-20UNF	1/2-20UNF	9/16-18UNF	3/4-16UNF	7/8-14UNF	1 1/16-12UNF	1 3/16-12UNF	1 5/16-12UNF	1 5/8-12UNF
D	1/16-NPTF	1/8-NPTF	1/4-NPTF	3/8-NPTF	1/2-NPTF	3/4-NPTF	1-11 1/2 NPTF	1 1/4-11 1/2 NPTF	1 1/2-11 1/2 NPTF	2-11 1/2 NPTF	2 1/2 - NPTF

**Table 5, Flange version: connection sizes**

Type listed in Table 3	Code letter, size										
	A	B	C	D	E	F	G	H	J	K	L
A	DN15	DN25	DN40	DN50	DN65	DN80	DN100	DN125	DN150	DN200	–
B	1/2" - 1500 psi	1" - 1500 psi	1 1/2" - 1500 psi	2" - 1500 psi	2 1/2" - 1500 psi	3" - 1500 psi	1/2" - 2500 psi	1" - 2500 psi	1 1/2" - 2500 psi	2" - 2500 psi	2 1/2" - 2500 psi
C	1/2"	3/4"	1"	1 1/4"	1 1/2"	2"	2 1/2"	3"	3 1/2"	4"	5"
D									–	–	–
E	DN32	DN40	DN50	DN65	DN80	DN100	DN125	DN150	–	DN25	–
F											

**Table 6, Gas valve models**

Code letter	Description
A	Gas valve G 3/4 male, with M28x1.5/M8
B	Gas valve in end cap M28x1.5/M8
C	Gas valve 1/2"-20UNF, male, with M16x2 (ISO 10945)
D	Gas valve M14x1.5, male, with male M16x1.5 (Minimes)
E	Gas valve G 3/4 male, with 7/8-14UNF-VG8
F	Gas valve in end cap M42x1.5/M12

## 4. STANDARD ITEMS

### 4.1. TECHNICAL DATA

The piston accumulators and spare parts described below are manufactured in carbon steel with a design 2 piston (aluminium or carbon steel, depending on the version) and a sealing system made from NBR/PTFE (MC = 2212 / 2112).

The table provides the most important data and dimensions for the following series: SK210/350

The part numbers provided refer to piston accumulators in accordance with PED (CC = U).  
Designs that differ from the standard types described below can be requested from HYDAC.

#### 4.1.1 Permissible operating temperature

As standard, a piston accumulator can be operated in the following temperature range:

-10 °C ... +80 °C

Other operating temperatures on request.

#### 4.1.2 Permitted operating pressure

The permitted operating pressure may differ from the nominal pressure in the case of other certifications. The table in section 4.2. shows the permitted operating pressure in accordance with the European Pressure Equipment Directive.

#### 4.1.3 Nominal volume

HYDAC piston accumulators are available with set nominal volumes, as described in the table in section 4.2.

#### 4.1.4 Effective gas volume

The effective gas volume differs slightly from the nominal volume and forms the basis of the calculated effective fluid volume.

The gas volume V is larger than the nominal volume by the amounts shown below.

Piston Ø D1 [mm]	Piston design			
	1	2	3	4
	$\Delta[l]$			
50	–	–	0.014	–
60	–	0.04	0.04	0.04
80	–	0.04	0.08	0.04
100	0.06	0.06	0.26	0.06
125	–	0.17	0.5	0.17
150	–	0.65	0.78	0.65
180	1.21	1.21	1.21	1.21
200	–	1	1.6	1
250	3.03	3.03	3.58	3.03
310	–	6.22	–	6.22
355	4.51	4.51	–	4.51
490	–	12.71	–	12.71

#### 4.1.5 Effective volume

Volume (fluid side) between operating pressures  $p_2$  and  $p_1$ .

#### 4.1.6 Limits for gas pre-charge pressure

For more information, see catalogue section:

- HYDAC Accumulator Technology  
No. 3.000

## 4.2. TABLES AND DRAWINGS

Nom. volume V min. - max.	Series	Perm. operating pressure (PED) [bar]	Ø D1 [mm]	Ø D2 [mm]	Length calculation <sup>1)</sup> $L = a + (b \cdot V)$		Weight <sup>2)</sup> min. - max. [kg]
					a [mm]	b [mm/l]	
0.2 – 5	SK350	350	60	80	126	353.7	6 – 35
0.5 – 10	SK350	350	80	100	157	198.9	11 – 48
0.5 – 15	SK350	350	100	125	184	127.3	19 – 85
1 – 50	SK350	350	125	160	185	81.5	32 – 280
2.5 – 70	SK210	210	150	180	210	56.6	47 – 280
	SK350	350			234		52 – 285
2.5 – 100	SK210	210	180	210	262	39.3	70 – 346
	SK350	350		220			79 – 458
2.5 – 200	SK210	210	200	235	290	31.8	100 – 690
	SK350	350					
10 – 200	SK210	210	250	286	408	20.4	173 – 731
	SK350	350		300			204 – 999
25 – 400	SK350	350	310	350	462	13.2	390 – 1110
25 – 750	SK210	210	355	404	534	10.1	472 – 2154
	SK350	350		434			594 – 3413
200 – 1300	SK210	210	490	570	700	5.3	1589 – 4492
	SK350	350					
300 – 3300	SK210	210	610	691	856	3.42	2500 – 11000
	SK350	350		710			

<sup>1)</sup> The lengths calculated are normally rounded up or down in 5 mm increments

<sup>2)</sup> Intermediate weights can be calculated approximately depending on the length/diameter required

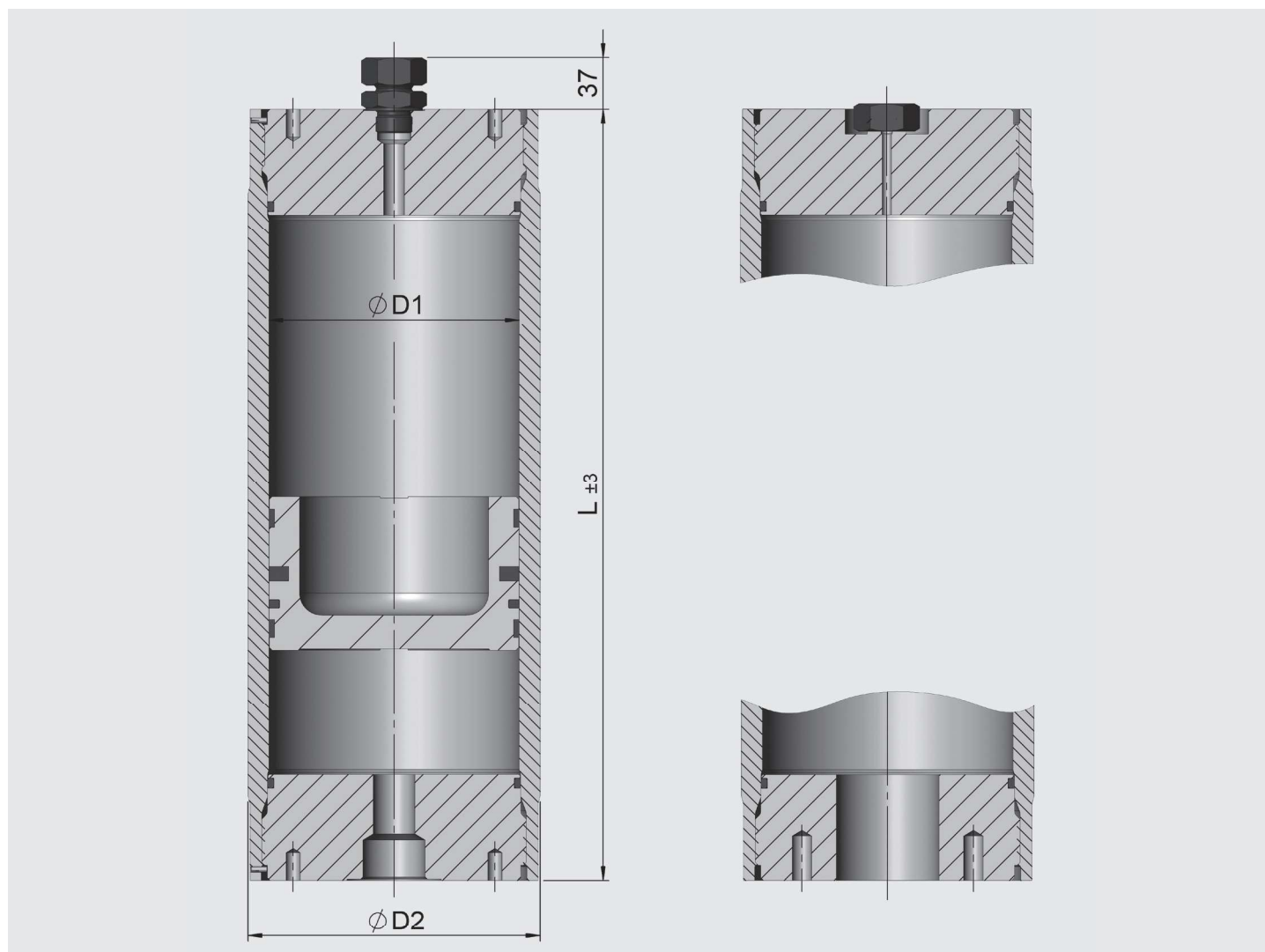

Nominal volume [l]	Series	Perm. operating pressure (PED) [bar]	Part no. <sup>1)</sup>	Ø D1 [mm]	Ø D2 ±3 [mm]	L [mm]	Gas side connection <sup>3)</sup>	Fluid side connection ISO 228	Weight [kg]
10	SK350	350	3946133	150	180	800	Gas valve VB	G 3/4	76
			3946157				G 3/4		
			3946158				Gas valve VA		77
20	SK350	350	3946159	150	180	1365	Gas valve VB	G 3/4	111
			3946161				G 3/4		
			3946164				Gas valve VA		112
	SK210	210	3946260	180	210	1050	G 3/4	G 3/4	119
			3946262				G 1 1/2	120	
			3586466				G 3/4		
			3123789				Gas valve VA	G 1 1/2	118
32	SK350	350	3946195	150	180	2045	Gas valve VB	G 3/4	152
			3946196				G 3/4		
			3946198				Gas valve VA		153
			3946330	180	220	1520	G 3/4	G 3/4	193
			3112126				G 1 1/2	189	
			3946331				Gas valve VA	G 3/4	194
	3123473	G 1 1/2	190						
	SK210	210	3946297	180	210	1520	G 3/4	G 3/4	153
			3152988				G 1 1/2		
			3946298				Gas valve VA	G 3/4	150
			3123470				G 1 1/2		
	SK350	350	3946383 <sup>2)</sup>	200	235	1310	G 3/4	G 3/4	174
			3946396 <sup>2)</sup>				Gas valve VA		175
50	SK350	350	3946332	180	220	2225	G 3/4	G 3/4	262
			3213717				G 1 1/2	250	
			3946333				Gas valve VA	G 3/4	262
			3123505				G 1 1/2	251	
	SK210	210	3946301	180	210	2225	G 3/4	G 3/4	203
			3823656				G 1 1/2		
			3946302				Gas valve VA	G 3/4	201
			3280844				G 1 1/2		
	SK350	350	3946399 <sup>2)</sup>	200	235	1880	G 3/4	G 3/4	228
			3946402 <sup>2)</sup>				Gas valve VA		229
			3221083 <sup>2)</sup>	250	300	1425	G 3/4	G 1 1/2	339
			3946442 <sup>2)</sup>				Gas valve VA		341
75	SK350	350	3946403 <sup>2)</sup>	200	235	2675	G 3/4	G 3/4	302
			3946438 <sup>2)</sup>				Gas valve VA		303
100	SK350	350	3484504 <sup>2)</sup>	250	300	2445	G 3/4	G 1 1/2	512
			3946475 <sup>2)</sup>				Gas valve VA		514

<sup>1)</sup> Preferred models, others on request

<sup>2)</sup> Material and piston code (MC) = 2112, see section 3.

<sup>3)</sup> Gas side connection, see section 3.

#### Notice:

Dimensions, particularly lengths, are approximate and dependent on various factors (e.g. piston design, approval). The specified values are maximum values and must not be considered as referring to a permanent load. The tolerable pressure ratio is influenced by the geometry, temperature, fluid and flow rate as well as any gas losses due to physical properties.

## 4.2.1 Spare parts

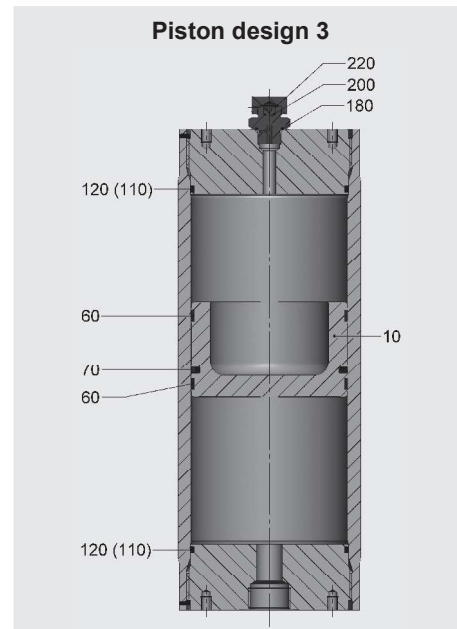
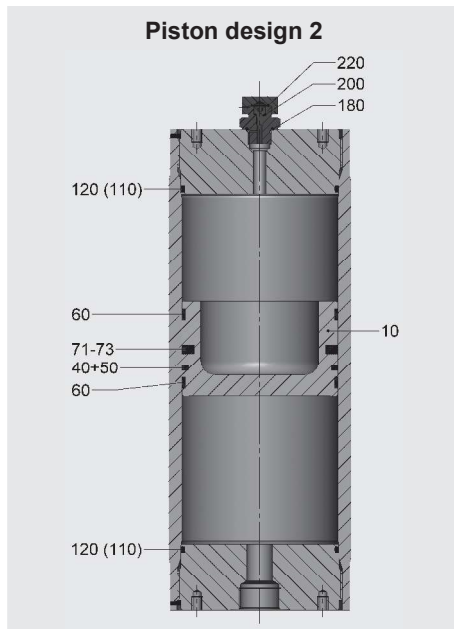
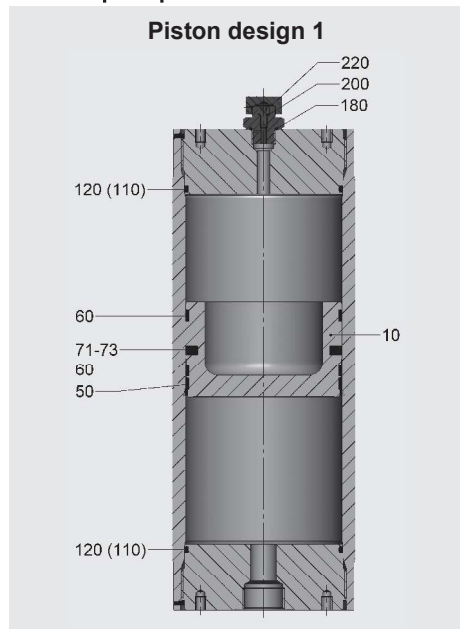

Description	Qty.	Item
-------------	------	------

### Piston assembly <sup>2)</sup> consisting of:

Piston	1	10
Seal ring	1	50
Guide ring	2	60
Centre seal	1	71-73

### Seal kit consisting of:

Seal ring	1	50
Guide ring	2	60
Centre seal	1	71-73
(Support ring)	(2)	(110)
O-ring	2	120
O-ring	1	180
Seal ring	1	200
O-ring	1	220

Description	Qty.	Item
-------------	------	------

### Piston assembly <sup>2)</sup> consisting of:

Piston	1	10
Seal ring	1	40+50
Guide ring	2	60
Centre seal	1	71-73

### Seal kit consisting of:

Seal ring	1	40+50
Guide ring	2	60
Centre seal	1	71-73
(Support ring)	(2)	(110)
O-ring	2	120
O-ring	1	180
Seal ring	1	200
O-ring	1	220

Description	Qty.	Item
-------------	------	------

### Piston assembly <sup>2)</sup> consisting of:

Piston	1	10
Guide ring <sup>1)</sup>	1/2	60
Seal ring	1	70

### Seal kit consisting of:

Guide ring <sup>1)</sup>	1/2	60
Seal ring	1	70
(Support ring)	(2)	(110)
O-ring	2	120
O-ring	1	180
Seal ring	1	200
O-ring	1	220

Pressure-bearing parts cannot be supplied as spares.

(...) for SK690 and standard SK, internal diameters 310 mm and above

<sup>1)</sup> The bottom guide ring for internal diameters 180 mm and above

<sup>2)</sup> Items (110), 120, 180, 200 and 220 are enclosed unassembled

Spare parts for piston design 4 are available on request.

## 4.2.2 Piston and seal kit

Piston design 1

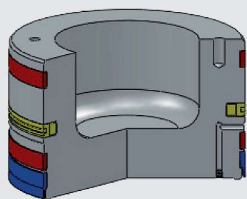

Piston design 2

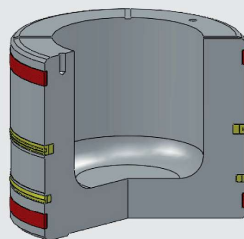

Piston design 3

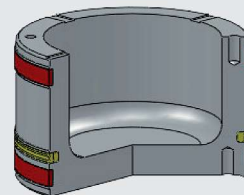

### Piston assembly

Piston Ø [mm]	NBR / PTFE Part no.	FKM / PTFE Part no.
60	–	–
80	–	–
100	3128922	3128926
125	–	–
150	–	–
180	3141888	3182493
200	–	–
250	3128924	3128938
310	–	–
355	3128925	3128939
490	–	–

### Piston assembly

Piston Ø [mm]	NBR / PTFE Part no.	FKM / PTFE Part no.
60	3183495	–
80	3183496	3183497
100	3175476	3183117
125	3016232	3016253
150	3016228	3016229
180	2118451	2112535
200	3110811	3016215
250	353980	353981
310	3016195	3016197
355	356382	354079
490	3128989	3128990

### Piston assembly

Piston Ø [mm]	NBR / PUR Part no.
60	3009372
80	2119931
100	2115547
125	3016150
150	3016231
180	3046277
200	3016218
250	3016171
310	–
355	4323005
490	4323006

### Seal kit

Piston Ø [mm]	NBR / PTFE Part no.	FKM / PTFE Part no.
60	–	–
80	–	–
100	3128940	3128944
125	–	–
150	–	–
180	3128941	3128945
200	–	–
250	3128942	3128946
310	–	–
355	3128943	3128947
490	–	–

### Seal kit

Piston Ø [mm]	NBR / PTFE Part no.	FKM / PTFE Part no.
60	3090507	–
80	3041573	3015745
100	363268	363269
125	3116665	3016234
150	3016235	3016237
180	363270	363271
200	3110810	3016242
250	363266	363267
310	3016200	3016201
355	363272	363273
490	3104100	3128991

### Seal kit

Piston Ø [mm]	NBR / PUR Part no.
60	3016210
80	3013230
100	2123414
125	2128104
150	3007546
180	2123415
200	3113127
250	3016213
310	4374872
355	3726888
490	3894300

## 4.2.3 Assembly sleeves



Special assembly sleeves are needed to assemble the piston and seals, see:

- Assembly and repair instructions for piston accumulators No. 3.301.M

## 5. ACCESSORIES

### 5.1. PISTON POSITION INDICATORS

Examples of piston monitoring devices.  
Further options for determining the piston position and detailed technical data available on request. See also flyer:

- Monitoring equipment for hydraulic accumulators  
No. 3.506

#### 5.1.1 Electrical limit switch

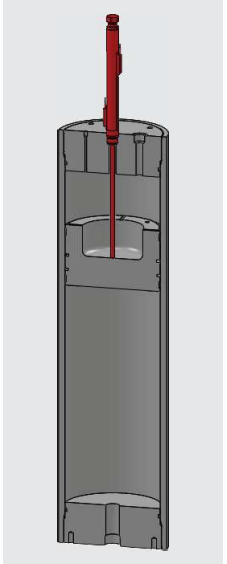

**What is measured?**

Max. or set fill level of the piston accumulator

**How are measurements taken?**

As point measurements

**Where to measure?**

Gas side

**Identification in the model code:**

A, B, C, ..., depending on stroke

**Product information:**

No. 10000769094

#### 5.1.2 Magnetic flap indication

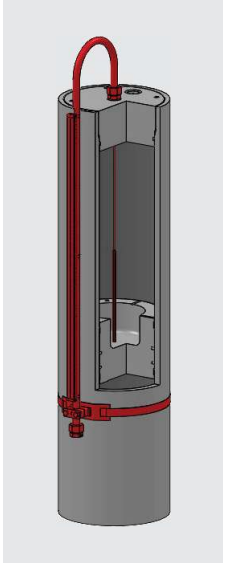

**What is measured?**

Piston position via a magnet fastened to the cable that moves coloured flaps that can be read from the outside

**How are measurements taken?**

Continuously

**Where to measure?**

Gas side

**Identification in the model code:**

M

**Product information:**

No. 10000769200

#### 5.1.3 Cable tension measurement system

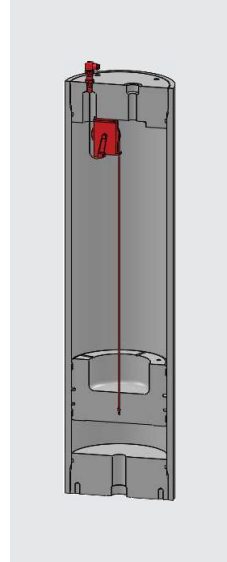

**What is measured?**

Piston position via a cable fastened to the piston

**How are measurements taken?**

Continuously

**Where to measure?**

Gas side

**Identification in the model code:**

S

**Product information:**

No. 10000641374

#### 5.1.4 Piston position switch

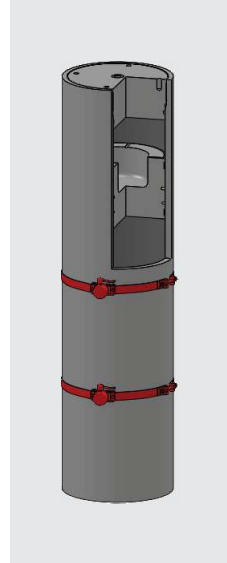

**What is measured?**

Piston position via ultrasonic measurement

**How are measurements taken?**

As point measurements

**Where to measure?**

Fluid side

**Identification in the model code:**

UP...

**Product information:**

No. 10000769179

### 5.1.5 Linear position measurement system

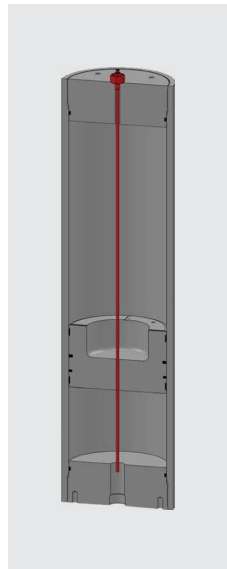

#### What is measured?

Piston position via elapsed time measurement

#### How are measurements taken?

Continuously

#### Where to measure?

Gas side

#### Identification in the model code:

L

#### Product information:

No. 10000810655

### 5.1.6 Laser linear position measurement system

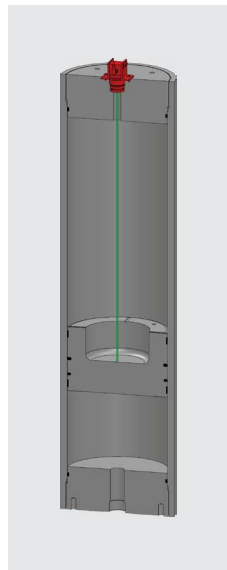

#### What is measured?

Piston position via laser elapsed time measurement

#### How are measurements taken?

Continuously

#### Where to measure?

Gas side

#### Identification in the model code:

LA

#### Product information:

No. 10000810664

## 6. NOTE

The information in this brochure relates to the operating conditions and fields of application described. For applications and/or operating conditions not described, please contact the relevant technical department.  
Subject to technical modifications.

HYDAC Technology GmbH  
Industriegebiet  
66280 Sulzbach/Saar, Germany  
Tel.: +49 68 97 / 509 - 01  
Internet: [www.hydac.com](http://www.hydac.com)  
E-mail: [speichertechnik@hydac.com](mailto:speichertechnik@hydac.com)

