

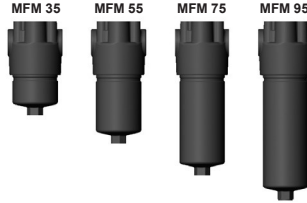

Inline Filter MFM

up to 100 l/min, up to 280 bar



1. TECHNICAL SPECIFICATIONS

1.1 FILTER HOUSING

Construction

The filter housings are designed in accordance with international regulations. They consist of a filter head and a screw-in filter bowl.

Standard equipment:

- bypass valve
- connection for a clogging indicator on the top of the head (4 mounting holes)
- filters are supplied phosphated and primed

1.2 FILTER ELEMENTS

HYDAC filter elements are validated and their quality is constantly monitored according to the following standards:

- ISO 2941
- ISO 2942
- ISO 2943
- ISO 3724
- ISO 3968
- ISO 11170
- ISO 16889

Filter elements are available with the following pressure stability values:
Optimicron® (ON): 20 bar

1.3 FILTER SPECIFICATIONS

Nominal pressure	280 bar
Fatigue strength	0 to 280 bar, min. 10 ⁷ cycles 0 to 320 bar, min. 10 ⁵ cycles
Temperature range	-10 °C to +100 °C (-30 °C to -10 °C: p _{max} = 140 bar)
Material of filter head	EN-GJS-400-15
Material of filter bowl	Steel
Type of clogging indicator	VD (differential pressure measurement up to 420 bar operating pressure)
Pressure setting of the clogging indicator	5 bar (others on request)
Bypass cracking pressure	7 bar (others on request)

1.4 SEALS

NBR (=Perbunan)

1.5 INSTALLATION

As inline filter

1.6 SPECIAL MODELS AND ACCESSORIES

Connection for a clogging indicator on the side of the head (3 mounting holes)

1.7 SPARE PARTS

See Original Spare Parts List

1.8 CERTIFICATES AND APPROVALS

On request

1.9 COMPATIBILITY WITH HYDRAULIC FLUIDS ISO 2943

- Hydraulic oils H to HLPD DIN 51524
- Lubrication oils DIN 51517, API, ACEA, DIN 51515, ISO 6743
- Compressor oils DIN 51506
- Biodegradable operating fluids VDMA 24568 HETG, HEES, HEPG
- Operating fluids with high water content (>50% water content) on request

1.10 MAINTENANCE INSTRUCTIONS

- Filter housings must be earthed.
- When using electrical clogging indicators, the electrical power supply to the system must be switched off before removing the clogging indicator connector.

Symbol for hydraulic systems

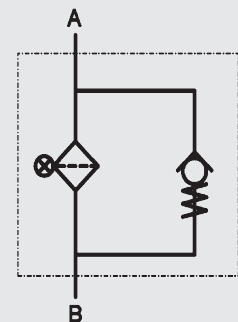

2. MODEL CODE (also order example)

MFM ON 55 O D 10 D 4 . X /-L24-B7

2.1 COMPLETE FILTER

Filter type

MFM

Filter material

ON Optimicron®

Size of filter or element

MFM: 35, 55, 75, 95

Operating pressure

O = 280 bar

Type and size of connection

Type	Connection	Filter size			
		35	55	75	95
A	M18 x 1.5	●	●	●	●
B	G ½	●	●	●	●
D	M22 x 1.5	●	●	●	●
H	G ¾	●	●	●	●

Filtration rating in µm

ON: 1, 3, 5, 10, 15, 20

Type of clogging indicator

- W without port (no clogging indicator)
 - A plastic blanking plug in indicator port
 - B visual
 - C electrical
 - D visual and electrical
- for other clogging indicators, see brochure no. 7.050../..

Type code

- 3 clogging indicator port on side of head - 3 mounting holes
- 4 clogging indicator port on top of head - 4 mounting holes

Modification number

- X the latest version is always supplied

Supplementary details

- B7 standard: bypass cracking pressure 7 bar
 - L... light with appropriate voltage (24, 48, 110, 220 Volt)
 - LED 2 light-emitting diodes up to 24 Volt
 - V FPM seals
 - W suitable for HFA and HFC emulsions
 - WAL right-angled bracket for side mounting, inlet on left (only possible for type code 4.x)
 - WAR right-angled bracket for side mounting, inlet on right (only for type code 4.x)
- only for clogging indicators type "D"

2.2 REPLACEMENT ELEMENT

0055 D 010 ON /-V

Size

0035, 0055, 0075, 0095

Type

D

Filtration rating in µm

ON: 001, 003, 005, 010, 015, 020

Filter material

ON

Supplementary details

- V (for descriptions, see Point 2.1)

2.3 REPLACEMENT CLOGGING INDICATOR

VD 5 D . X /-L24

Type of indicator

- VD differential pressure indicator up to 450 bar operating pressure

Pressure setting

- 5 standard 5 bar, others on request

Type of clogging indicator

- D (see Point 2.1)

Modification number

- X the latest version is always supplied

Supplementary details

- L..., LED, V, W (for descriptions, see Point 2.1)

3. FILTER CALCULATION / SIZING

The total pressure drop of a filter at a certain flow rate Q is the sum of the housing Δp and the element Δp and is calculated as follows:

$$\Delta p_{\text{total}} = \Delta p_{\text{housing}} + \Delta p_{\text{element}}$$

$$\Delta p_{\text{housing}} = \text{(see Point 3.1)}$$

$$\Delta p_{\text{element}} = Q \cdot \frac{SK^*}{1000} \cdot \frac{\text{viscosity}}{30}$$

(*see Point 3.2)

For ease of calculation, our Filter Sizing Program is available on request free of charge.

NEW: Sizing online at www.hydac.com

3.1 Δp -Q HOUSING CURVES BASED ON ISO 3968

The housing curves apply to mineral oil with a density of 0.86 kg/dm³ and a kinematic viscosity of 30 mm²/s. In this case, the differential pressure changes proportionally to the density.

MFM - Port M18 x 1.5 / G 1/2

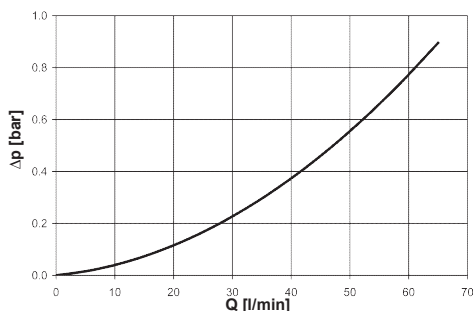

MFM - Port M22 x 1.5 / G 3/4

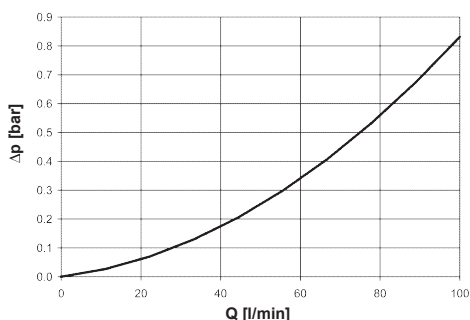

3.2 GRADIENT COEFFICIENTS (SK) FOR FILTER ELEMENTS

The gradient coefficients in mbar/(l/min) apply to mineral oils with a kinematic viscosity of 30 mm²/s. The pressure drop changes proportionally to the change in viscosity.

MFM	ON					
	1 μm	3 μm	5 μm	10 μm	15 μm	20 μm
35	50.2	21.3	17.1	13.7	10.0	7.44
55	26.0	12.3	9.9	7.90	5.17	3.84
75	16.7	8.4	6.75	5.4	3.33	2.48
95	13.2	6.74	5.4	4.33	2.62	1.92

4. DIMENSIONS

STANDARD VERSION 4.X

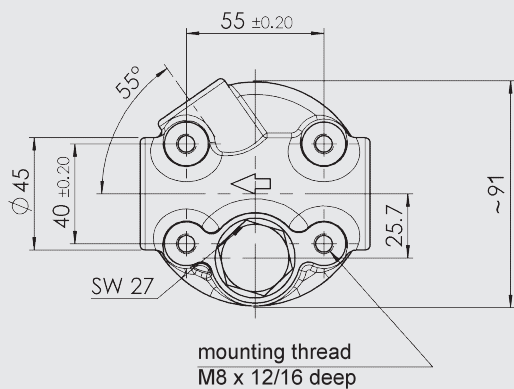
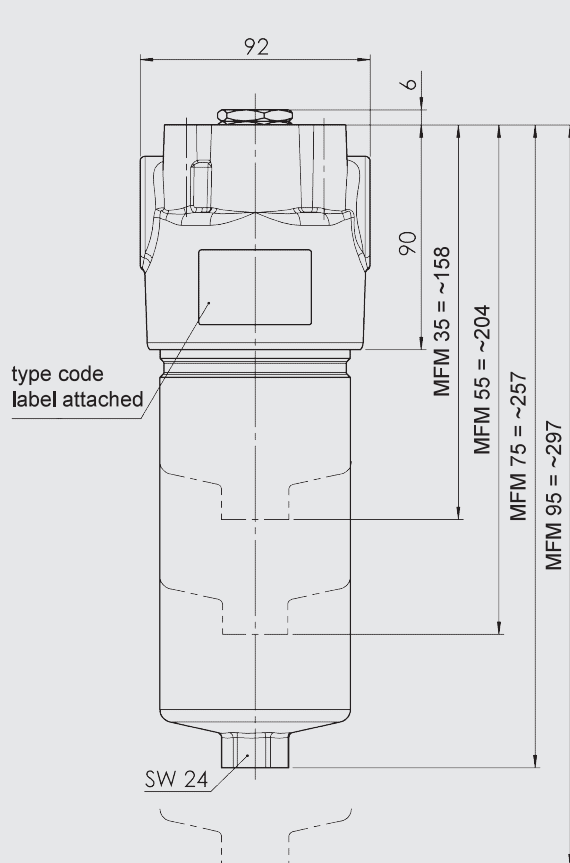

SPECIAL VERSION 3.X

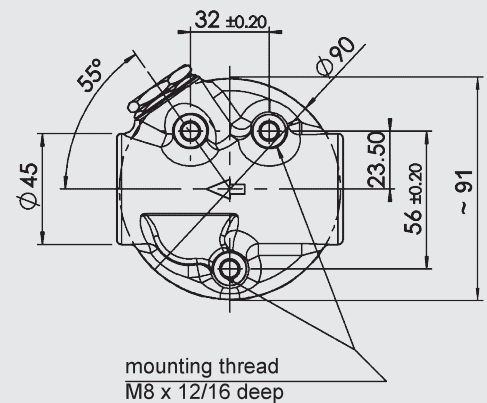
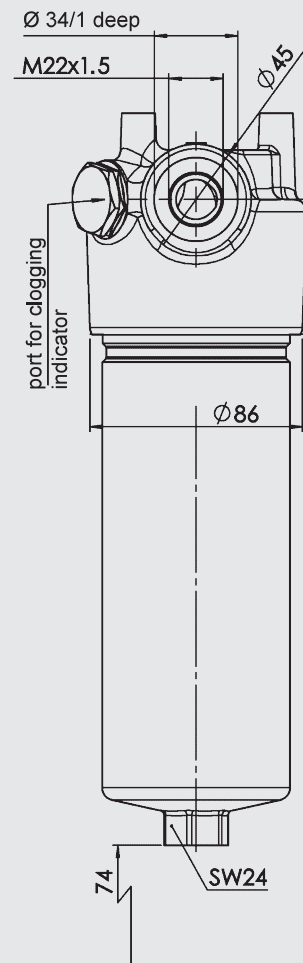
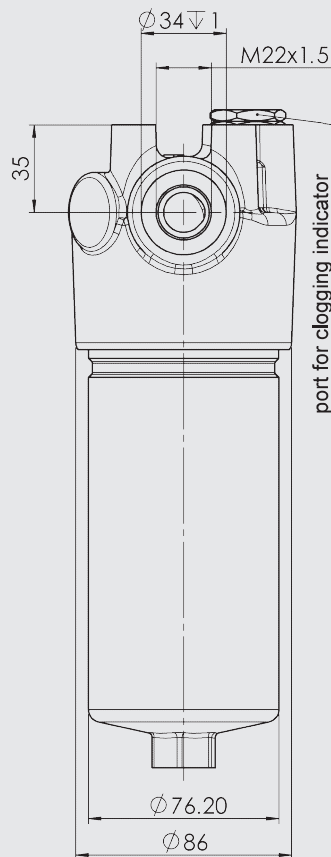

MFM	Weight incl. element [kg]	Vol. of pressure chamber [l]
35	3.7	0.24
55	4.2	0.39
75	4.7	0.56
95	5.1	0.69

NOTE

The information in this brochure relates to the operating conditions and applications described. For applications or operating conditions not described, please contact the relevant technical department. Subject to technical modifications.

HYDAC Filtrertechnik GmbH
 Industriegebiet
D-66280 Sulzbach/Saar
 Tel.: 0 68 97 / 509-01
 Fax: 0 68 97 / 509-300
 Internet: www.hydac.com
 E-Mail: filter@hydac.com