



Inline filters NF up to 3500 l/min, up to 25 bar



1. TECHNICAL SPECIFICATIONS

1.1 FILTER HOUSING Construction

The filter housings are designed in accordance with international regulations. They consist of a filter housing and a threaded cover plate. Standard equipment:

- bypass valve
- port for clogging indicator

1.2 FILTER ELEMENTS

HYDAC filter elements are validated and their quality is constantly monitored according to the following standards:

- ISO 2941
- ISO 2942
- ISO 2943
- ISO 3724
- ISO 3968
- ISO 11170
- ISO 16889

Number of filter elements

NF	Elements
160	1x0160 R
240	1x0240 R
280	1x0280 R
330	1x0330 R
500	1x0500 R
750	1x0750 R
950	1x0950 R
13xx	1x1300 R
26xx	1x2600 R
5240	2x2600 R
7840	3x2600 R
10440	4x2600 R

Filter elements are available with the following pressure stability values:

Optimicon® (ON):	20 bar
Optimicon® Pulp & Paper (ON/PP):	10 bar
Stainl. st. wire mesh (W/HC):	20 bar
Stainless steel fibre (V):	30 bar
Ecomicon® (ECON2)	10 bar
Paper (P/HC)	10 bar
Betamicron®/Aquamicron® (BN4AM):	10 bar
Aquamicron® (AM)	10 bar

1.3 FILTER SPECIFICATIONS

Nominal pressure	25 bar
Max. operating pressure	30 bar at max. 10 ⁶ cycles
Temperature range	-10 °C to +100 °C
Material of filter head	Aluminium
Material of tube (housing)	Steel up to NF 750 Aluminium for NF 950 and above
Material of cover plate	Aluminium
Type of clogging indicator	VM (differential pressure measurement)
Pressure setting of clogging indicator	2 bar (others on request)
Bypass cracking pressure	3 bar (others on request)

1.4 SEALS

NBR (=Perbunan)

1.5 MOUNTING

Inline filter

1.6 SPECIAL MODELS AND ACCESSORIES

- Mounting bracket for NF 1310, 1340, 2610, 2640
- Mounting flange for NF 1340/2640
- Filling connection for NF 330, 500, 750, 950, 1350, 2650 on the contaminated side
- Foot bracket option for NF 160-750, 950, 1350, 2650
- Quick release coupling on the filling connection for NF 160, 240, 280
- Check valve on the clean side for NF 160, 240, 280
- For applications up to 40 bar, please make separate request! (only for NF 950, 1350, 2650)
- NF filter as tank-top return line filter (type code 1.x) and as inline filter (horizontal inlet flange at top, outlet vertical; type code 3.x) on request

1.7 SPARE PARTS

See Original Spare Parts List

1.8 CERTIFICATES AND APPROVALS

On request

1.9 COMPATIBILITY WITH HYDRAULIC FLUIDS ISO 2943

- Hydraulic oils H to HLPD DIN 51524
- Lubrication oils DIN 51517, API, ACEA, DIN 51515, ISO 6743
- Compressor oils DIN 51506
- Biodegradable operating fluids VDMA 24568 HETG, HEES, HEPG
- Fire-resistant fluids HFA, HFB, HFC and HFD
- Operating fluids with high water content (>50% water content) on request

1.10 IMPORTANT INFORMATION

- Filter housings must be earthed.
- When using visual clogging indicators, the BM version (visual with manual reset) only should be used.
- When using electrical clogging indicators, the electrical power supply to the system must be switched off before removing the clogging indicator connector.

Symbol for hydraulic systems

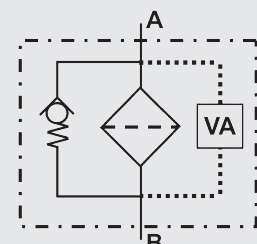

VA = clogging indicator

2. MODEL CODE (also order example)

NF ON 2640 D P 10 D 2 . X /-L24

2.1 COMPLETE FILTER

Filter type

NF

Filter material

ON Optimicron® P/HC Paper BN/AM Betamicron®/Aquamicron®
 ON/PP* Optimicron® Puls & Paper W/HC Stainl. st. wire mesh AM Aquamicron®
 V Stainless steel fibre ECO/N Ecomircron® (ECON2)

Size of filter or element

NF: 160, 240, 280, 330, 500, 750, 950, 1310, 1340, 1350, 2610, 2640, 2650, 5240, 7840, 10440

Operating pressure

D = 25 bar

Type and size of connection

Type	Port	Filter size																
		160	240	280	330	500	750	950	1310	1340	1350	2610	2640	2650	5240	7840	10440	
E	G 1 1/4	●	●	●														
F	G 1 1/2				●	●	●											
K	SAE DN 40 (1½")				●	●	●											
L	SAE DN 50 (2")							●			●				●			
M	SAE DN 65 (2½")							●			●				●			
N	SAE DN 80 (3")							●			●				●			
P	SAE DN 100 (4")							●	○	●	●	○	●	●	●	●	●	●

○ = Discontinued model

Filtration rating in µm

ON: 1, 3, 5, 10, 15, 20 ECO/N, V: 3, 5, 10, 20 P/HC: 10, 20 AM: 40
 ON/PP*: 5 W/HC: 25, 50, 100, 200 BN/AM: 3, 10

Type of clogging indicator

A with steel blanking plug in indicator port
 BM visual
 C electrical
 D visual and electrical
 for other clogging indicators see brochure no. 7.050../..

Type code (TKZ)

2

Modification number

X the latest version is always supplied

Supplementary details

B. special cracking pressure of bypass (e. g. B6 = 6 bar); no details = standard 3 bar
 EM manual vent with shut-off valve
 EP permanent vent via Minimesse hose
 FF mounting flange for NF 1340/2640
 KB without bypass valve
 L... light with appropriate voltage (24, 48, 110, 220 Volt)
 LED 2 light emitting diodes up to 24 Volt
 SB4 filling line with Ø 4 mm
 V FPM seals
 only for clogging indicators type "D"

2.2 REPLACEMENT ELEMENT

2600 R 010 ON /-V

Size

0160, 0240, 0280, 0330, 0500, 0750, 0950, 1300, 2600

Type

R

Filtration rating in µm

ON: 001, 003, 005, 010, 015, 020 ECON2, V: 003, 005, 010, 020 P/HC: 010, 020 AM: 040
 ON/PP*: 005 W/HC: 025, 050, 100, 200 BN4AM: 003, 010

Filter material

ON, ON/PP*, ECON2, V, W/HC, P/HC, BN4AM, AM

Supplementary details

V (for descriptions, see point 2.1)

2.3 REPLACEMENT CLOGGING INDICATOR

VM 5 D . X /-L24

(IMPORTANT: the clogging indicator must not be screwed into the cover plate)

Type

VM Differential pressure indicator

Pressure setting

2 2 bar (5 = 5 bar), others on request

Type of clogging indicator (see point 2.1)

Modification number

X the latest version is always supplied

Supplementary details

L..., LED, V (for descriptions, see point 2.1)

* for BG 1340 filters and above

2.4 INLINE FILTER – INDIVIDUAL SHUT-OFF CAPABILITY

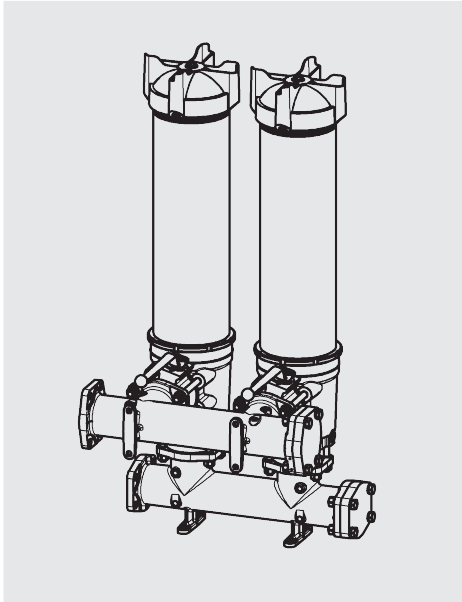

TECHNICAL DESCRIPTION

The NF n+1 filter series has been developed in line with the classic NF filters. It features a ball change-over valve from HYDAC Filtrertechnik GmbH and offers a cost-efficient and space saving alternative to the classic, fully duplex version of the NF series. In comparison to the previous butterfly change-over valve with 16 bar operating pressure, the new HYDAC ball change-over valve is rated to the higher operating pressure of 25 bar. Since each filter tower can be shut off individually using the ball change-over valve, the filters can be changed while the system is running, guaranteeing 24 hour operation.

Flow rate: 500–4000 l/min
 Nom. pressure: up to 25 bar
 Size: 5240, 7840, 10440 (others on request)

MODEL CODE

NF ON 5240 D P 10 D 4 X /-L24

Filter type

NF

Filter material (see point 2.1)

Size of filter or element

NF: 5240, 7840, 10440

Operating pressure

D = 25 bar

Type and size of connection

Type	Port	Filter size		
		5240	7840	10440
P	SAE DN 100 (4")	●	●	●

Filtration rating in μm (see point 2.1)

Type of clogging indicator (see point 2.1)

Type code

4 individual shut-off capability

Modification number

X the latest version is always supplied

Supplementary detail (see point 2.1)

DIMENSIONS

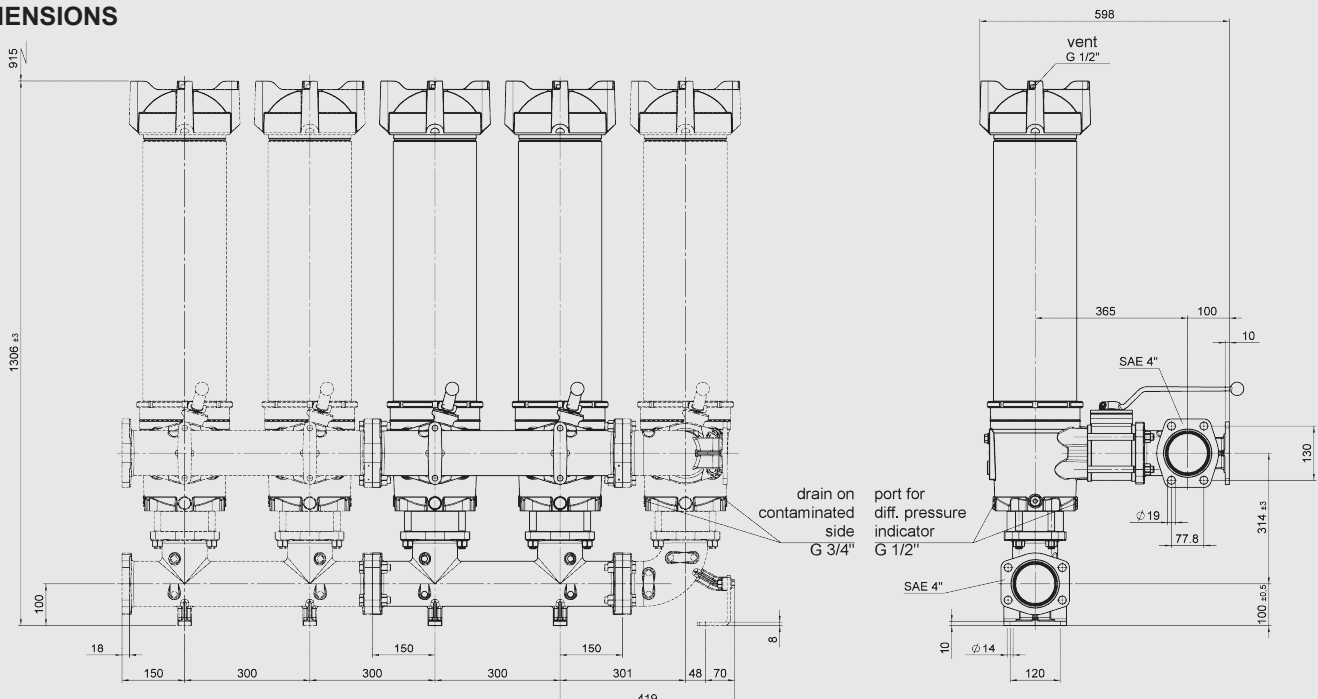

3. FILTER CALCULATION / SIZING

The total pressure drop of a filter at a certain flow rate Q is the sum of the housing Δp and the element Δp and is calculated as follows:

$$\Delta p_{\text{total}} = \Delta p_{\text{housing}} + \Delta p_{\text{element}}$$

$$\Delta p_{\text{housing}} = (\text{see Point 3.1})$$

$$\Delta p_{\text{element}} = Q \cdot \frac{SK^*}{1000} \cdot \frac{\text{viscosity}}{30}$$

(*see point 3.2)

For ease of calculation, our Filter Sizing Program is available on request free of charge.

NEW: Sizing online at www.hydac.com

3.1 Δp -Q HOUSING CURVES BASED ON ISO 3968

The housing curves apply to mineral oil with a density of 0.86 kg/dm³ and a kinematic viscosity of 30 mm²/s. In this case, the differential pressure changes proportionally to the density.

NF 160, 240, 280

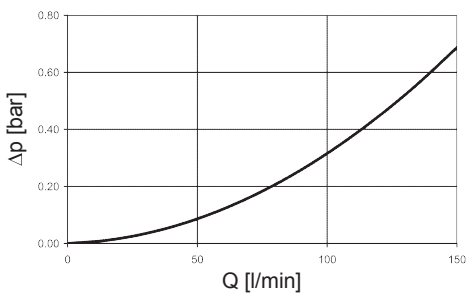

NF 330, 500, 750

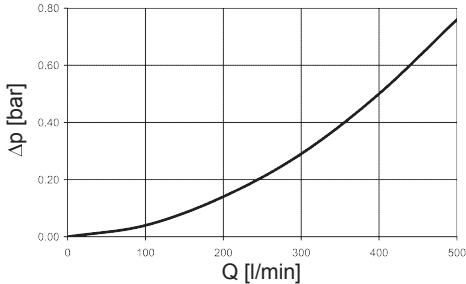

NF 1310, 2610 NF 1340, 2640 NF 950, 1350, 2650

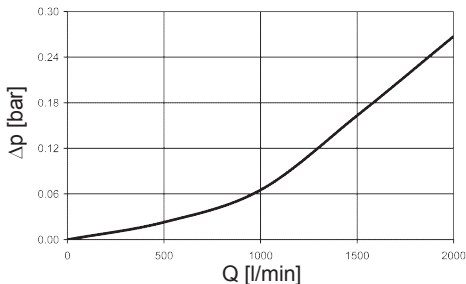

NF 5240

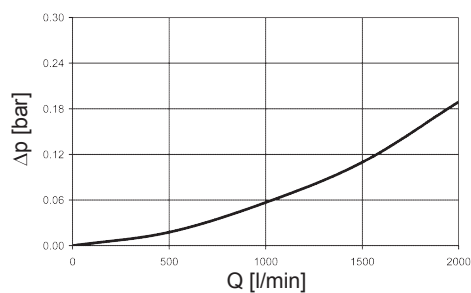

NF 7840

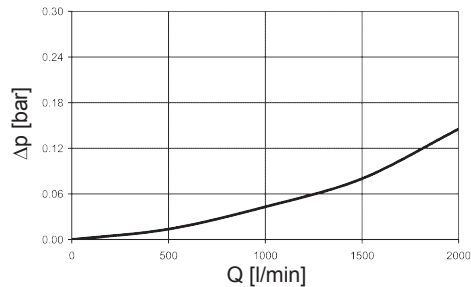

NF 10440

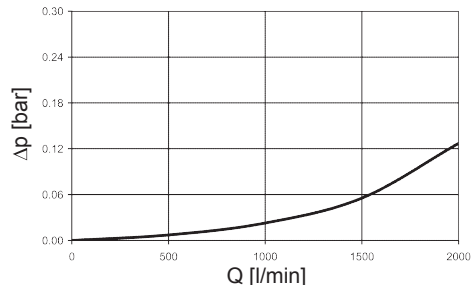

3.2 GRADIENT COEFFICIENTS (SK) FOR FILTER ELEMENTS

The gradient coefficients in mbar/(l/min) apply to mineral oils with a kinematic viscosity of 30 mm²/s. The pressure drop changes proportionally to the change in viscosity.

NF	ON						ON/PP
	1 µm	3 µm	5 µm	10 µm	15 µm	20 µm	5 µm
160	16.0	8.00	5.68	3.22	2.69	2.32	—
240	10.4	5.18	3.66	2.27	1.84	1.41	—
280	5.10	2.57	2.08	1.43	1.06	0.80	—
330	8.09	3.72	2.73	1.48	1.28	1.02	—
500	5.27	2.60	1.90	1.09	0.84	0.69	—
750	2.11	1.12	0.92	0.53	0.34	0.32	—
950	2.39	1.03	0.79	0.48	0.38	0.31	—
1300	1.72	0.72	0.59	0.35	0.32	0.22	1.00
2600	0.84	0.36	0.29	0.18	0.16	0.11	0.45

NF	V				W/HC	ECON2			
	3 µm	5 µm	10 µm	20 µm	—	3 µm	5 µm	10 µm	20 µm
160	4.9	3.5	2.4	1.5	0.193	9.5	5.9	3.8	2.9
240	3.2	2.6	1.7	1.2	0.123	6.2	3.8	2.6	1.8
280	1.4	1.1	0.7	0.5	0.017	3.1	2.2	1.6	1.0
330	2.1	1.7	1.1	0.8	0.195	4.2	2.7	1.7	1.2
500	1.5	1.2	0.8	0.5	0.128	3.0	1.9	1.3	0.8
750	0.6	0.5	0.3	0.2	0.049	1.3	0.9	0.6	0.4
950	0.7	0.6	0.4	0.2	0.048	1.2	0.8	0.5	0.4
1300	0.5	0.4	0.3	0.2	0.034	0.8	0.6	0.4	0.3
2600	0.3	0.2	0.1	0.1	0.017	0.4	0.3	0.2	0.1

4. DIMENSIONS

NF 160-280

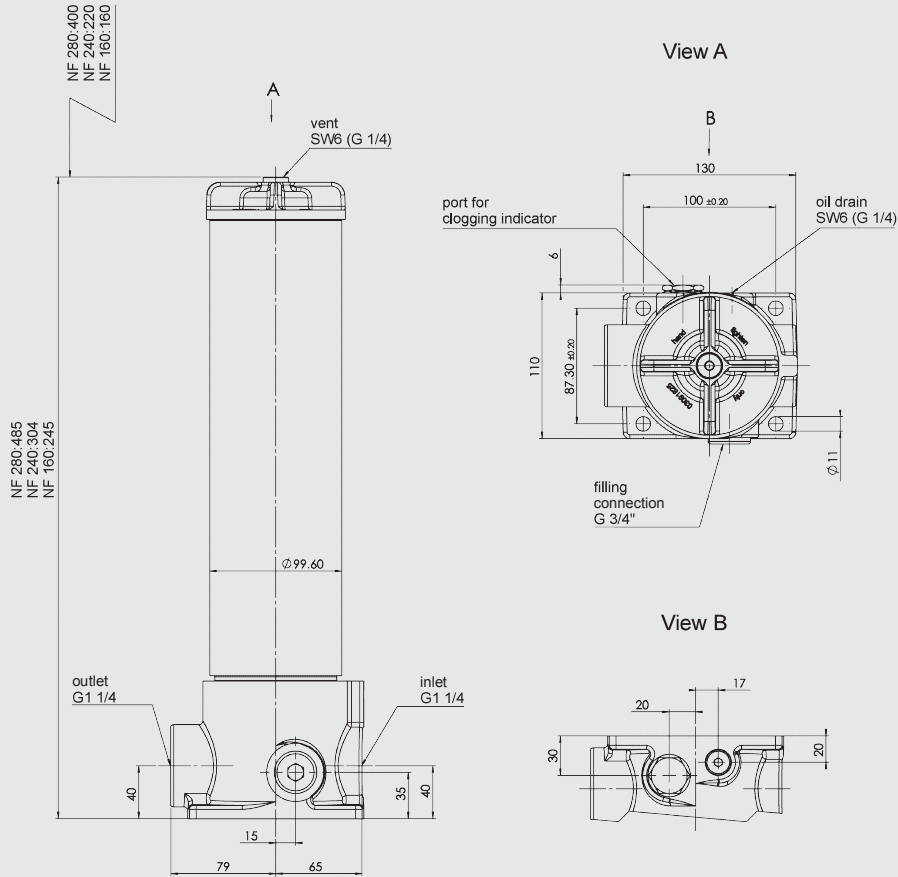

NF 330-750

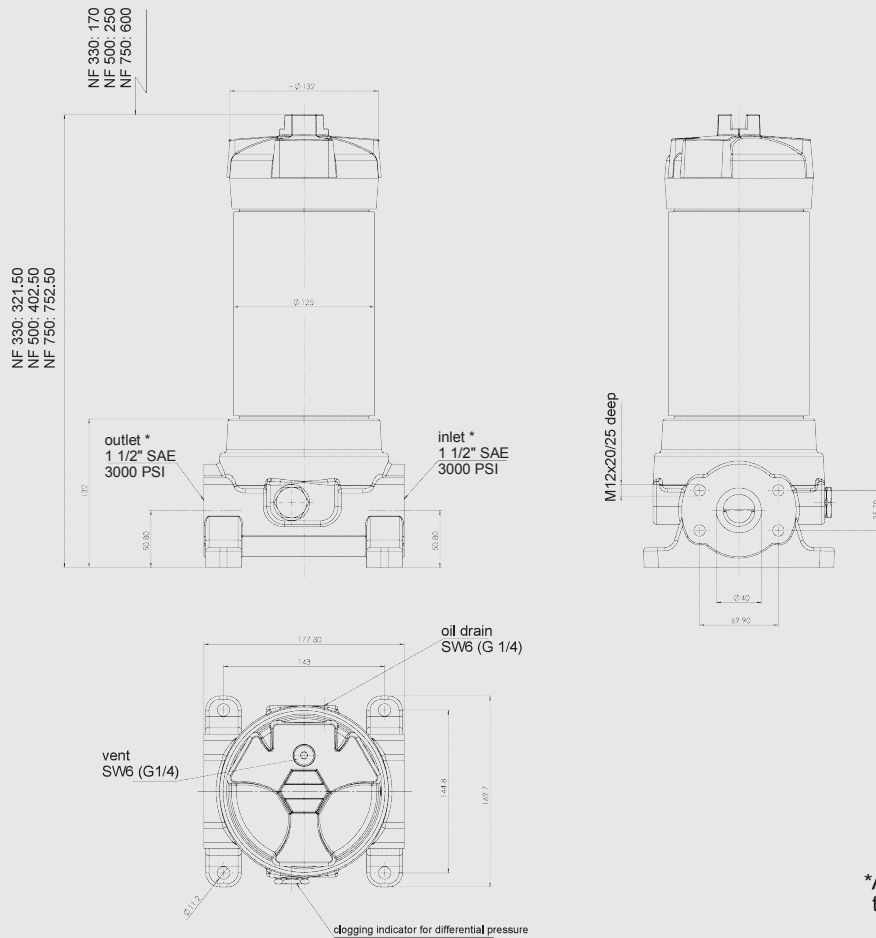

*Alternatively:
threaded connection G 1 1/2

NF	No. of elements	Weight incl. element [kg]	Vol. of pressure chamber [l]
160	1x0160 R...	4,5	0,8
240	1x0240 R...	5,6	1,1
280	1x0280 R...	9,1	2,1

NF	No. of elements	Weight incl. element [kg]	Vol. of pressure chamber [l]
330	1x0330 R...	7,8	2,05
500	1x0500 R...	9,0	2,80
750	1x0750 R...	14,1	6,08

NF 950, 1350, 2650

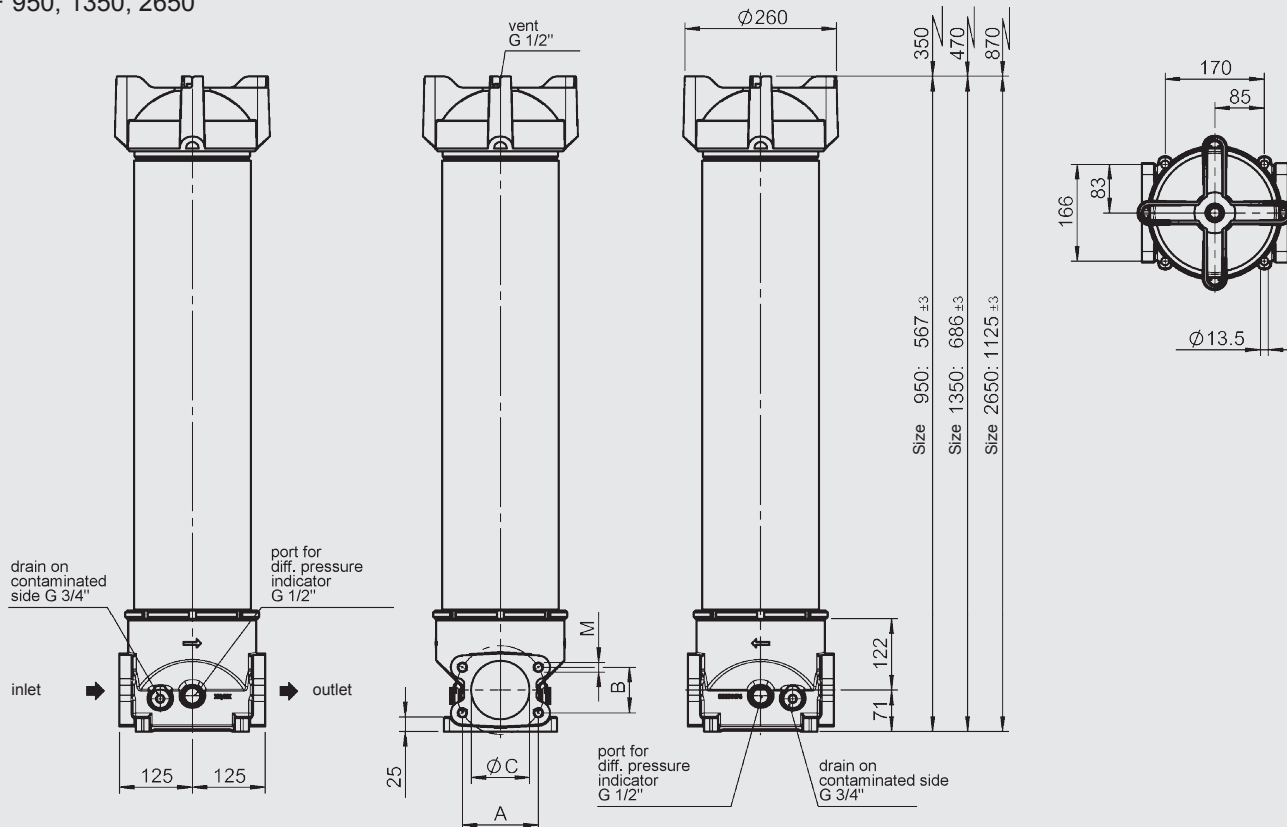

NF 1310/2610 ... 2.X (on request)

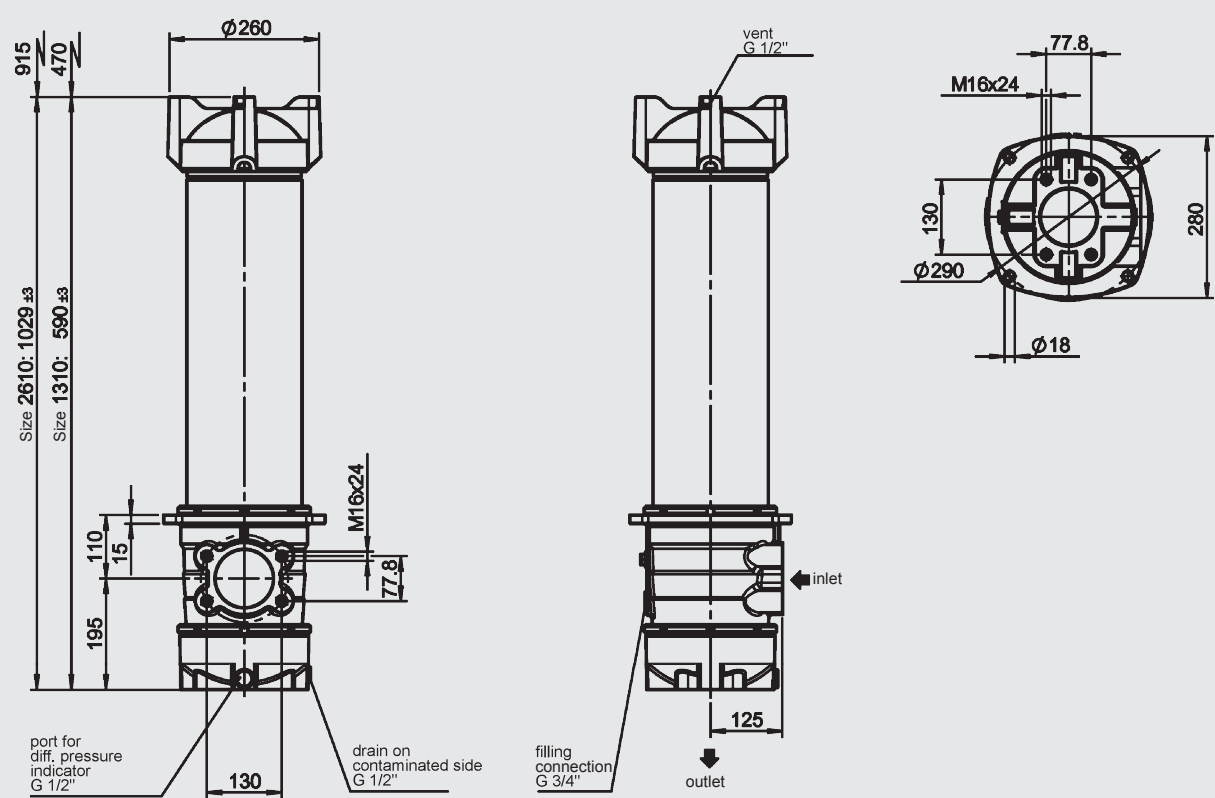

Port	A	B	ØC	M
SAE DN 50 (2")	77.8	42.9	50	M12x15
SAE DN 65 (2½")	88.9	50.8	65	M12x15
SAE DN 80 (3")	106.4	62.9	75	M16x24
SAE DN 100 (4")	130.2	77.8	100	M16

NF	No. of elements	Weight incl. element [kg]	Vol. of pressure chamber [l]
1310...2.X	1x1300 R...	17	14

NF	No. of elements	Weight incl. element [kg]	Vol. of pressure chamber [l]
950	1x0950 R...	16	10
1350	1x1300 R...	18	13
2650	1x2600 R...	25	25

NF	No. of elements	Weight incl. element [kg]	Vol. of pressure chamber [l]
2610...2.X	1x2600 R...	23	25

NF 1340/2640 ... 2.X/-FF

NF 1340/2640 ... 2.X

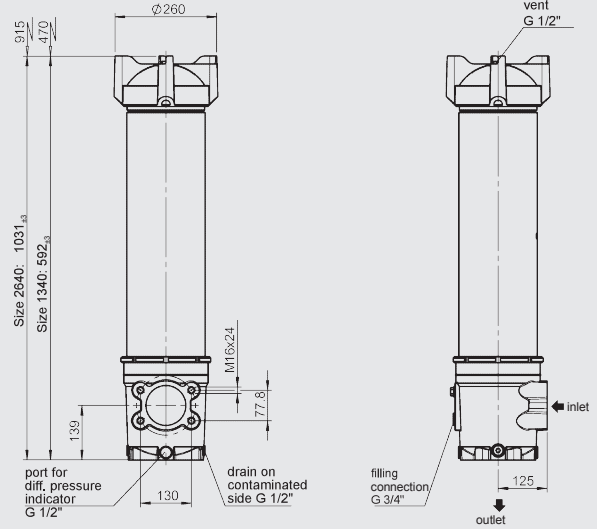
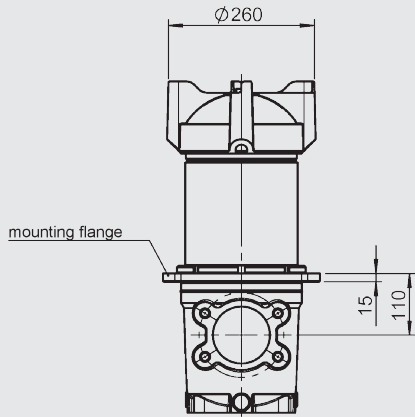
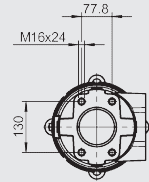
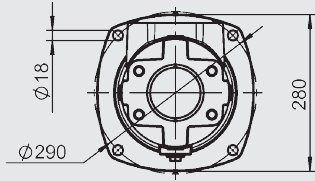

NF 5240 ... 2.X

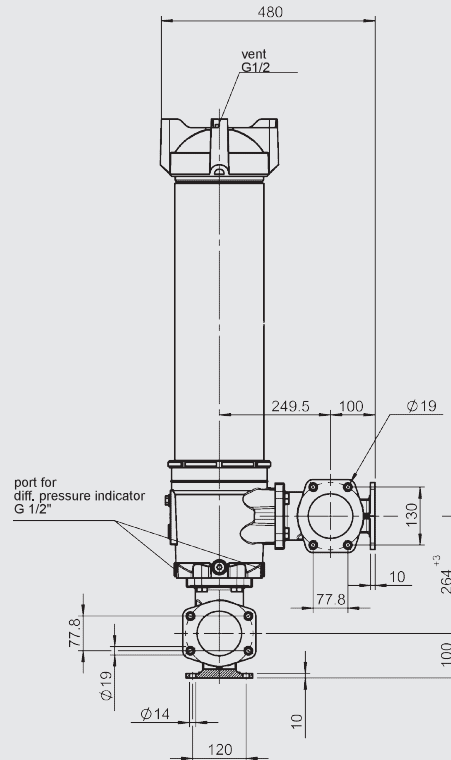
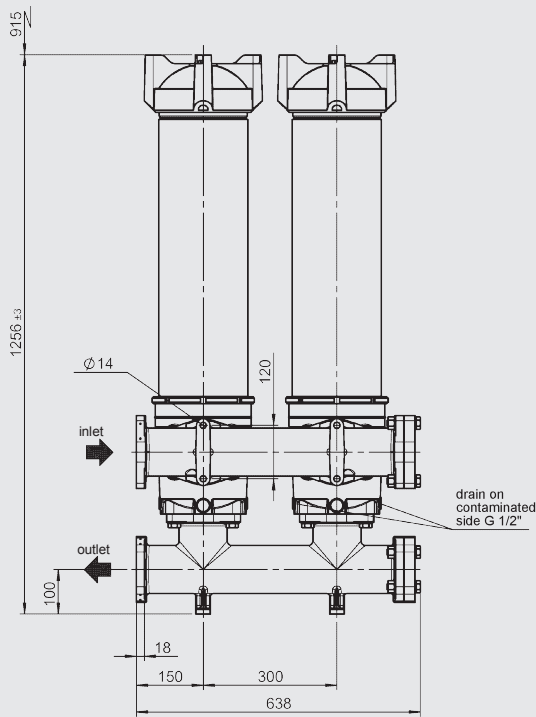

NF	No. of elements	Weight incl. element [kg]	Vol. of pressure chamber [l]
1340...2.X	1x1300 R...	17	14

NF	No. of elements	Weight incl. element [kg]	Vol. of pressure chamber [l]
2640...2.X	1x2600 R...	23	25

NF	No. of elements	Weight incl. element [kg]	Vol. of pressure chamber [l]
5240...2.X	2x2600 R...	90	60

NF 7840 2.x

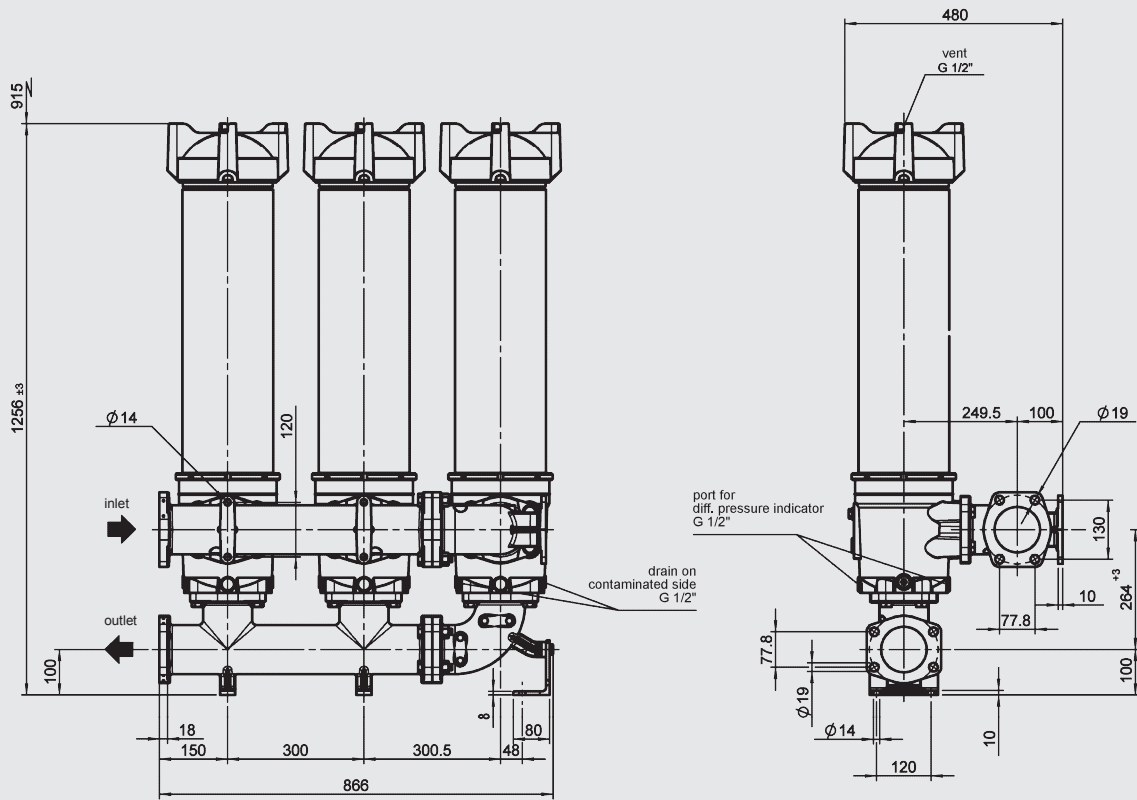

NF 10440 2.x

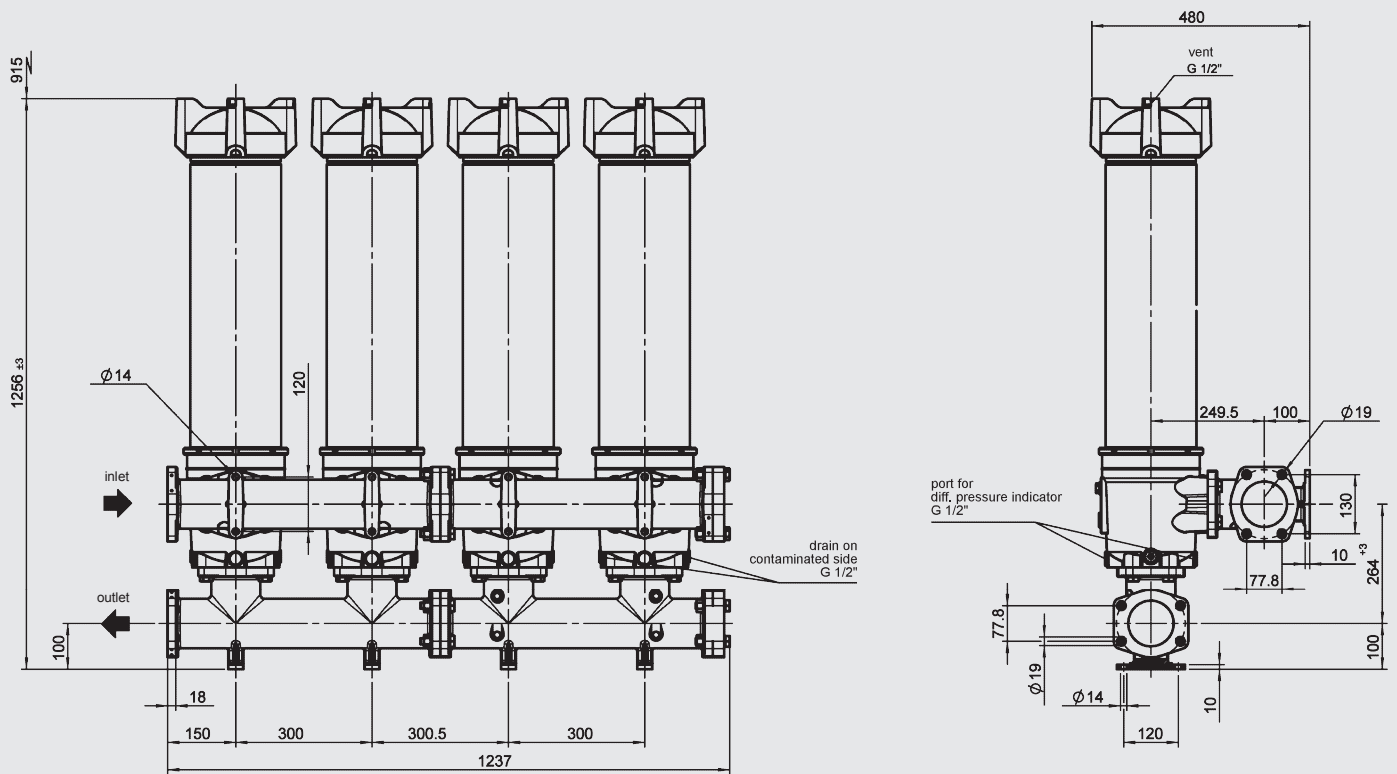

NF	No. of elements	Weight incl. element [kg]	Vol. of pressure chamber [l]
7840	3x2600 R...	125	88

NF	No. of elements	Weight incl. element [kg]	Vol. of pressure chamber [l]
10440	4x2600 R...	180	120

