

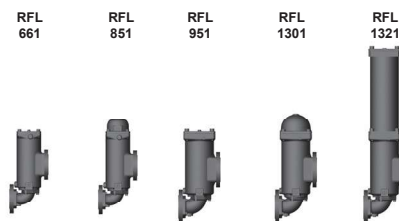

Inline Filter RFL Cast Version up to 1300 l/min, up to 40 bar



1. TECHNICAL SPECIFICATIONS

1.1 FILTER HOUSING

Construction

The filter housings are designed in accordance with international regulations. They consist of a two-piece filter housing with a bolt-on cover plate.

Standard equipment:

- with bypass valve
- connections for venting and draining
- connection for a clogging indicator

1.2 FILTER ELEMENTS

HYDAC filter elements are validated and their quality is constantly monitored according to the following standards:

- ISO 2941
- ISO 2942
- ISO 2943
- ISO 3724
- ISO 3968
- ISO 11170
- ISO 16889

Filter elements are available with the following pressure stability values:

Optimicon® (ON):	20 bar
Optimicon® Power (ON/PO):	10 bar
Paper (P/HC):	10 bar
Stainl. st. wire mesh (W/HC):	20 bar
Stainl. st. fibre (V):	30 bar
Betamicon®/Aquamicron® (BN4AM):	10 bar
Aquamicron® (AM):	10 bar

1.3 FILTER SPECIFICATIONS

Nominal pressure	25 bar 40 bar (RFL 662 to 1322 to AD)
Temperature range	-10 °C to +100 °C
Material of filter housing and cover plate	EN-GJS-400-15 : RFL 661 to 1321 GP 240 GH+N : RFL 662 to 1322 On RFL 1321 and 1322 the extension is in steel!
Type of clogging indicator	VM (differential pressure measurement up to 210 bar operating pressure)
Pressure setting of the clogging indicator	2 bar (others on request)
Bypass cracking pressure	3 bar (others on request)

1.4 SEALS

NBR (=Perbunan)

1.5 INSTALLATION

Inline filter

1.6 SPECIAL MODELS AND ACCESSORIES

- without bypass valve
- Inlet and outlet positioned one above the other
- Counter flanges as welding or blank flanges

1.7 SPARE PARTS

See Original Spare Parts List

1.8 CERTIFICATES AND APPROVALS

These filters can be supplied with manufacturer's test certificates O and M to DIN 55350, Part 18.

Test certificates 3.1 to DIN EN 10204 and approval certificates

(Type Approval) for different approval authorities. Areas of application, amongst others: lubrication.

Filter to API 614 (ANSI flange) on request!

1.9 COMPATIBILITY WITH HYDRAULIC FLUIDS ISO 2943

- Hydraulic oils H to HLPD DIN 51524
- Lubrication oils DIN 51517, API, ACEA, DIN 51515, ISO 6743
- Compressor oils DIN 51506
- Biodegradable operating fluids VDMA 24568 HETG, HEES, HEPG
- Fire-resistant fluids HFA, HFB, HFC and HFD
- Operating fluids with high water content (>50% water content) on request

1.10 IMPORTANT INFORMATION

- Filter housings must be earthed.
- When using electrical clogging indicators, the electrical power supply to the system must be switched off before removing the clogging indicator connector.
- Filters must be flexibly mounted and not fixed rigidly to the floor or used as a pipe support.
- When used with W/HC and P/HC elements, please follow the sizing recommendation under point 3.3!

Symbol for hydraulic systems

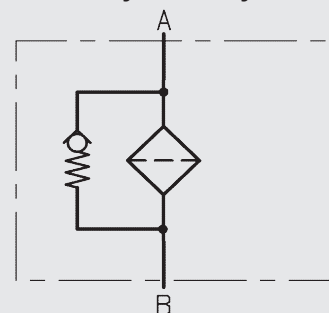

2. MODEL CODE (also order example)

RFL ON 851 D N 10 D 1 . X /-L24

2.1 COMPLETE FILTER

Filter type

RFL

Filter material

ON Optimicron® P/HC Paper AM Aquamicron®
 ON/PO Optimicron® Power* W/HC Stainl. st. wire mesh BN/AM Betamicron®/Aquamicron®
 V Stainless steel fibre

Size of filter or element

RFL: 661, 662, 851, 951, 952, 1301, 1302, 1321, 1322

Operating pressure

D = 25 bar
 E = 40 bar (RFL 662-1322 according to AD)

Type and size of connection

Type	Connection	Filter size				
		661	851	951	1301	1321
		662		952	1302	1322
N	SAE DN 80 (3")	●	●			
P	SAE DN 100 (4")			●	●	●
Q	DIN DN 80	●	●			
R	DIN DN 100			●	●	●

Other nominal bores on request

Filtration rating in µm

ON: 1, 3, 5, 10, 15, 20 P/HC: 10, 20 BN/AM: 3, 10
 ON/PO*, V: 3, 5, 10, 20 W/HC: 25, 50, 100, 200 AM: 40

Type of clogging indicator

Y plastic blanking plug in indicator port
 A steel blanking plug in indicator port
 B visual
 C electrical
 D visual and electrical
 for other clogging indicators, see brochure no. 7.050../..

Type code

1

Modification number

X the latest version is always supplied

Supplementary details

B. special cracking pressure of bypass (e.g. B1 = 1 bar)
 GA counter flange as welding flange
 GB counter flange as blank flange
 KB without bypass valve
 L... light with appropriate voltage (24V, 48V, 110V, 220V)
 LED 2 light emitting diodes up to 24 Volt
 OR O-ring groove on the DIN flange (inlet and outlet) to Rexroth standard AB 22-04
 V FPM seals
 33 inlet and outlet positioned one above the other
 SAK contamination retainer

2.2 REPLACEMENT ELEMENT

0850 R 010 ON /-V

Size

0660, 0850, 0950, 1300, 2600

Type

R

Filtration rating in µm

ON: 001, 003, 005, 010, 015, 020 W/HC: 025, 050, 100, 200 BN4AM: 003, 010
 ON/PO*, V: 003, 005, 010, 020 P/HC: 010, 020 AM: 040

Filter material

ON, ON/PO*, V, W/HC, P/HC, BN4AM, AM

Supplementary details

V (for descriptions, see point 2.1)

2.3 REPLACEMENT CLOGGING INDICATOR

VM 2 D . X /-L24

Type

VM differential pressure measurement up to 210 bar operating pressure

Pressure setting

2 standard 2 bar, others on request

Type of clogging indicator (see Point 2.1)

Modification number

X the latest version is always supplied

Supplementary details

L..., LED, V (for descriptions, see point 2.1)

* Optimicron® Power only in filtration rating 5, 10 and 20 µm

3. FILTER CALCULATION / SIZING

The total pressure drop of a filter at a certain flow rate Q is the sum of the housing Δp and the element Δp and is calculated as follows:

$$\Delta p_{\text{total}} = \Delta p_{\text{housing}} + \Delta p_{\text{element}}$$

$$\Delta p_{\text{housing}} = (\text{see Point 3.1})$$

$$\Delta p_{\text{element}} = Q \cdot \frac{SK^*}{1000} \cdot \frac{\text{viscosity}}{30}$$

(*see point 3.2)

For ease of calculation, our Filter Sizing Program is available on request free of charge.

NEW: Sizing online at www.hydac.com

3.1 Δp -Q HOUSING CURVES BASED ON ISO 3968

The housing curves apply to mineral oil with a density of 0.86 kg/dm³ and a kinematic viscosity of 30 mm²/s. In this case, the differential pressure changes proportionally to the density.

RFL 661, 662, 851

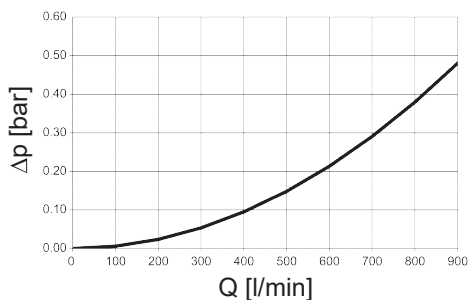

RFL 951, 952, 1301, 1302, 1321, 1322

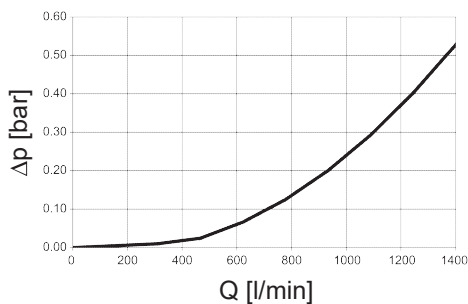

3.2 GRADIENT COEFFICIENTS (SK) FOR FILTER ELEMENTS

The gradient coefficients in mbar/(l/min) apply to mineral oils with a kinematic viscosity of 30 mm²/s. The pressure drop changes proportionally to the change in viscosity.

RFL	ON						ON/PO		
	1 μm	3 μm	5 μm	10 μm	15 μm	20 μm	5 μm	10 μm	20 μm
660	3.57	1.69	1.21	0.67	0.57	0.45	0.35	0.30	0.19
850	2.77	1.31	1.00	0.58	0.44	0.36	0.28	0.24	0.16
950	2.39	1.03	0.79	0.48	0.38	0.31	0.25	0.21	0.14
1300	1.72	0.72	0.59	0.35	0.32	0.22	0.18	0.15	0.10
2600	0.84	0.36	0.29	0.18	0.16	0.11	0.08	0.07	0.05

RFL	V				W/HC
	3 μm	5 μm	10 μm	20 μm	–
660	1.0	0.8	0.6	0.4	0.067
850	0.8	0.6	0.4	0.3	0.052
950	0.7	0.6	0.4	0.2	0.048
1300	0.5	0.4	0.3	0.2	0.034
2600	0.3	0.2	0.1	0.1	0.017

3.3 SIZING RECOMMENDATION

Filter type	Connection	Q _{max} when using W/HC and P/HC elements
RFL 661/662	DIN DN 80 SAE DN 80	480 l/min 480 l/min
RFL 851	DIN DN 80 SAE DN 80	480 l/min 480 l/min
RFL 951/952	DIN DN 100 SAE DN 100	900 l/min 900 l/min
RFL 1301/1302/1321/1322	DIN DN 100 SAE DN 100	900 l/min 900 l/min

4. DIMENSIONS

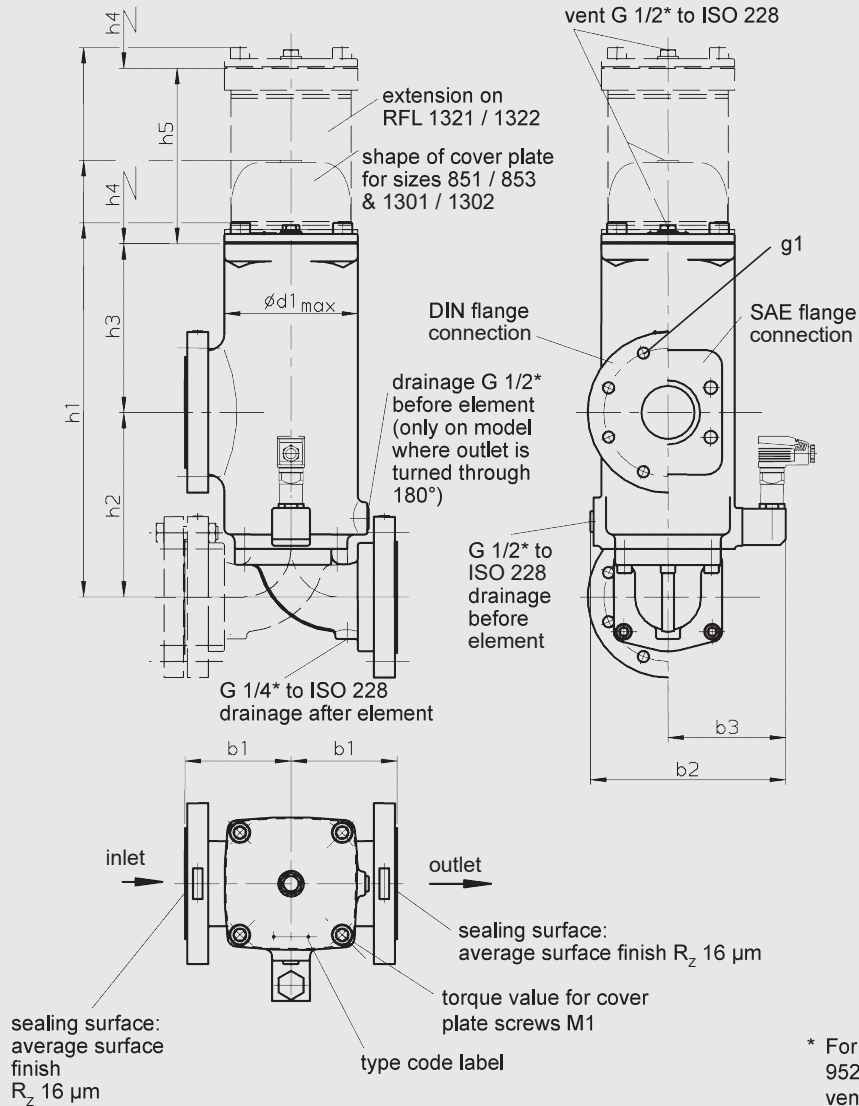

RFL	Flange connection ¹⁾	b1	b2	b3	d1	h1	h2	h3	h4	h5	M1 (Nm)	g1	Weight including element [kg]	Volume of pressure chamber [l]
661	SAE DN 80 DIN DN 80	133	243	147	166	465	230	210	350	-	150	M16 M16	36	8.2
662	SAE DN 80 DIN DN 80	133	238	144	177	465	230	210	350	-	150	M16 M16	42	8.2
851	SAE DN 80 DIN DN 80	133	243	147	166	552	230	210	420	-	150	M16 M16	38.5	9.5
951	SAE DN 100 DIN DN 100	143	271	161	194	523	250	238	380	-	250	M16 M20	54	13
952	SAE DN 100 DIN DN 100	143	264	157	200	523	250	238	380	-	250	M16 M20	67.5	13
1301	SAE DN 100 DIN DN 100	143	271	161	194	630	250	238	500	-	250	M16 M20	55.5	16
1302	SAE DN 100 DIN DN 100	143	264	157	200	630	250	238	500	-	250	M16 M20	75.5	16
1321	SAE DN 100 DIN DN 100	143	271	161	194	1084	250	238	940	561	250	M16 M20	82	31
1322	SAE DN 100 DIN DN 100	143	264	157	200	1084	250	238	940	561	250	M16 M20	96	31

1) Flange connection to SAE J 518 C (standard pressure series 3000 psi);
DIN flange connection to DIN EN ISO 1092, PN 25/40 to DN 100 (with sealing strip, flange shape B)

NOTE

The information in this brochure relates to the operating conditions and applications described.
For applications or operating conditions not described, please contact the relevant technical department.
Subject to technical modifications.

HYDAC Filtrertechnik GmbH
Industriegebiet
D-66280 Sulzbach/Saar
Tel.: 0 68 97 / 509-01
Fax: 0 68 97 / 509-300
Internet: www.hydac.com
E-Mail: filter@hydac.com