

Valve amplifier for proportional valves with electrical position feedback

Type VT-MRPA1-...

RE 30221

Edition: 2015-02

Replaces: 2013-08



H7076

- ▶ Component series 1X
- ▶ Analog, modular design
- ▶ Intended for controlling direct operated proportional pressure relief valves with electrical position feedback (type DBETR-1X) or proportional flow control valves with electrical position feedback (type 2FRE...)

Features

- ▶ Command value input +10 V (differential input)
- ▶ Ramp generator with separately adjustable ramp time "up/down"
- ▶ Zero point potentiometer
- ▶ Amplitude attenuator
- ▶ Enable input
- ▶ Reverse polarity protection for voltage supply
- ▶ Power supply unit with DC/DC converter without raised zero point
- ▶ Cable break detection in the position transducer branch
- ▶ LED indicators:
 - Ready for operation (green)
 - Enable (yellow)
- ▶ Measuring sockets for:
 - Command value "w"
 - Actual value "x"
 - Ramp times "t <", "t >"

Contents

| | |
|--|---|
| Features | 1 |
| Ordering codes | 2 |
| Functional description | 3 |
| Block diagram/pin assignment | 4 |
| Technical data | 5 |
| Terminal assignment | 6 |
| Dimensions | 6 |
| Project planning/maintenance instructions/ additional information | 7 |
| Setting recommendation | 7 |

Ordering codes

| | | | | | | | | | | |
|-----------------|----------|------------|----------|-----------|----------|-----------|----------|----------|----------|----------|
| 01 | 02 | 03 | 04 | 05 | 06 | | | | | |
| VT-MRPA1 | - | 100 | - | 1X | / | V0 | / | 0 | / | * |

| | | |
|----|---|-----------------|
| 01 | Analog amplifier in modular design | VT-MRMA1 |
| 02 | For controlling the valve DBETR-1X | 100 |
| | For controlling the valve 2FRE6-2X | 150 |
| | For controlling the valves 2FRE10-4X and 2FRE16-4X | 151 |
| 03 | Component series 10 to 19 (10 to 19: Unchanged technical data and pin assignment) | 1X |
| 04 | Version: Standard | V0 |
| 05 | Standard option | 0 |
| 06 | Further details in the plain text | * |

Functional description

General

The amplifier modules are snapped onto top hat rails according to EN 60715. The electrical connection is established via screw terminals. The modules are operated at 24 V direct voltage.

Power supply unit [1]

The amplifier modules have a power supply unit with making current limiter. This unit supplies all internally required positive and negative supply voltages. The making current limiter prevents high making current peaks.

Command value presetting

The internal command value signal is calculated from the total [3] of the external command value signal available at the differential input [2] and the zero point offset (zero point potentiometer "Zw").

A positive command value results in a current increase in the solenoid and thus a pressure increase in the valve.

Enable function [11]

The enable function enables the power output stages and forwards the internal command value signal to the ramp generator. The enable signal is displayed by an LED on the front plate. If enable is connected, the internal command value is changed (with any kind of command value presetting) by the set ramp time. Thus, a controlled valve does not open abruptly.

Ramp generator [4]

The ramp generator limits the rise of the control output. The amplitude attenuator does not extend or shorten the ramp time.

Notice for setting and measuring the ramp time:

| Value at measuring socket "t <" or "t >" | U_t in V | 5 | 3 | 2 |
|--|------------|----|----|----|
| Current ramp time ($\pm 20\%$) | t in ms | 20 | 33 | 50 |

| U_t in V | 1 | 0.5 | 0.3 | 0.2 | 0.1 | 0.05 | 0.03 | 0.02 |
|------------|-----|-----|-----|-----|------|------|------|------|
| t in ms | 100 | 200 | 333 | 500 | 1000 | 2000 | 3333 | 5000 |

The following applies: $t = \frac{100 \text{ V ms}}{U_t}$

Example: measured $U_t = 5 \text{ V}$
 results in $t = \frac{100 \text{ V ms}}{5 \text{ V}} = 20 \text{ ms}$

Amplitude attenuator [5]

By means of the amplitude attenuator "Gw", the maximum value can be adjusted to the hydraulic requirements in a range between 0 and 100%.

Amplitude limiter [6]

The internal command value is limited to 0% and 110%.

Oscillator [9]

The oscillator creates the control signal for the inductive position transducer.

Demodulator [10]

The demodulator supplies the actual value signal of the valve spool position from the position transducer signal: $+100\% \triangleq +10 \text{ V}$ at the measuring socket "x".

Controller for the valve spool position [7]

The position controller is intended to minimize the valve hysteresis and is optimized in a valve-specific manner.

Power output stage [8]

The power output stage creates the clocked solenoid current for the proportional valve. The solenoid current is limited to approx. 1.85 A. The output stage output is short-circuit-proof. The output stage is de-energized in case of an internal fault signal or if the enable signal is missing.

Fault recognition [14]

The position transducer cable is monitored for cable break and over-current at the output stage.

[] = References to the block diagram on page 4

Block diagram/pin assignment

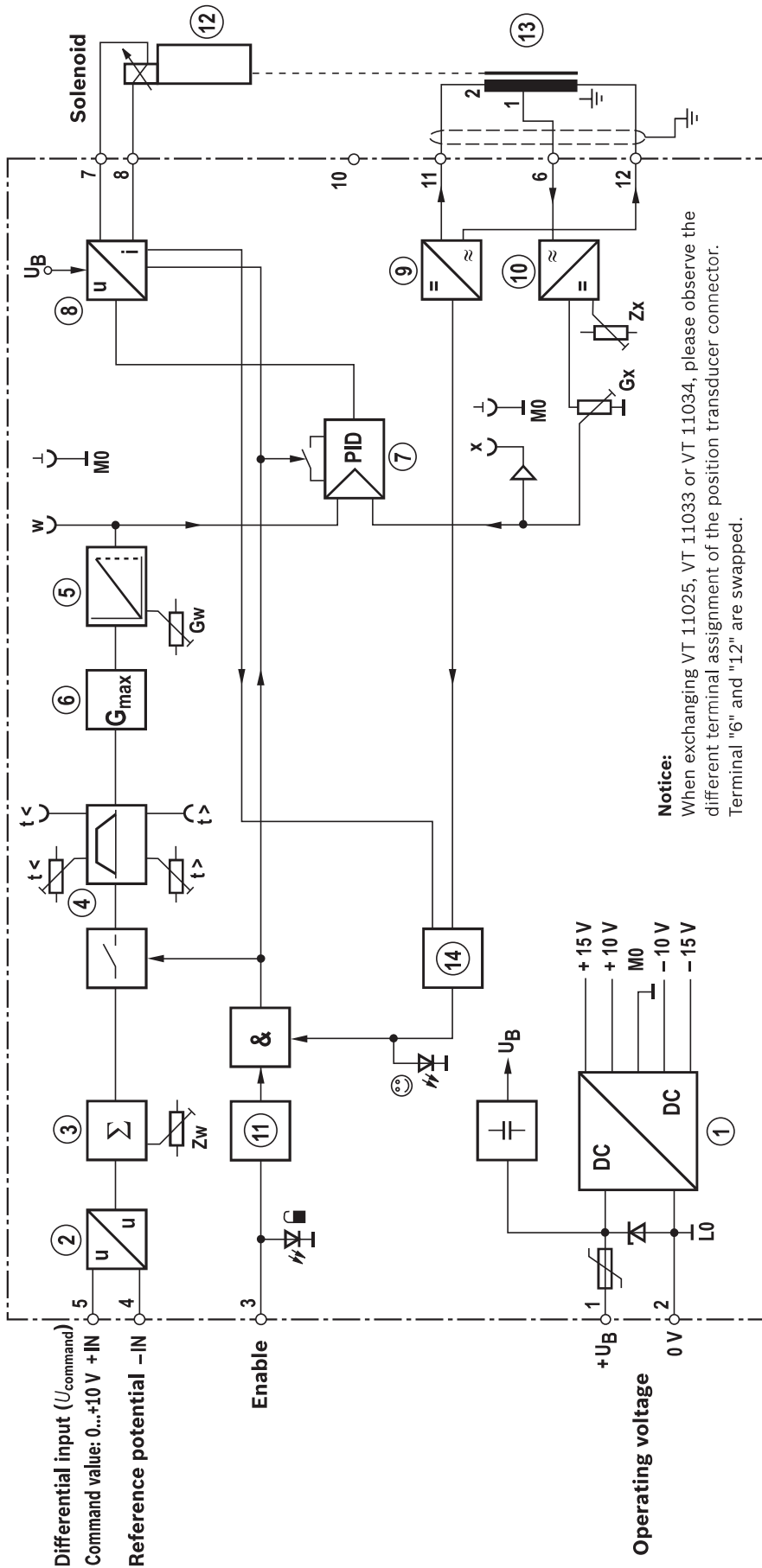

Notice:
When exchanging VT 11025, VT 11033 or VT 11034, please observe the different terminal assignment of the position transducer connector. Terminal "6" and "12" are swapped.

- | | | |
|------------------------------------|---------------------------------------|---|
| Zw Zero point command value | 1 Power supply unit | 10 Demodulator |
| Zx Zero point actual value | 2 Differential amplifier | 11 Enable function |
| t < Ramp time "up" | 3 Command value summing device | 12 Proportional valve |
| t > Ramp time "down" | 4 Ramp generator | 13 Inductive position transducer |
| Gw Amplitude attenuator | 5 Amplitude attenuator | 14 Fault recognition |
| Gx Sensitivity actual value | | |
| w Command value | | |
| x Actual value | | |
| ☺ Ready for operation | | |
| 🔒 Enable | | |

Technical data (for applications outside these parameters, please consult us!)

| | | |
|---|-----------------|--|
| Operating voltage | U_B | 24 VDC + 40% – 20% |
| Operating range: | | |
| – Upper limit value | $u_B(t)_{\max}$ | 35 V |
| – Lower limit value | $u_B(t)_{\min}$ | 18 V |
| Power consumption | P_S | < 24 VA |
| Current consumption | I | < 2 A |
| Fuse | | Thermal overload protection (with restart if the value falls below the temperature threshold) |
| Inputs: | | |
| – Analog | | |
| • Command value (differential input "±IN") | U_e | 0 to +10 V; $R_e > 50\text{ k}\Omega$ |
| – Digital | | |
| • Enable ON | U | 8.5 V to U_B ; $R_e > 100\text{ k}\Omega$ |
| OFF | U | 0 to 6.5 V; $R_e > 100\text{ k}\Omega$ |
| Setting ranges: | | |
| – Zero point command value (potentiometer "Zw") | | ±10% |
| – Zero point actual value (potentiometer "Zx") | | ±10% |
| – Ramp times (potentiometer "t <" and "t >") | t | 20 ms to 5 s |
| – Amplitude attenuator (potentiometer "Gw") | | 0% to 110% (applies to the zero point setting = 0%) |
| Outputs: | | |
| – Power output stages | I | 0 to 1.85 A; short-circuit-proof; clocked approx. 5 kHz |
| – Oscillator | U_{SS} | 2 V; 10 mA per output |
| | f | 5.6 kHz ± 10% |
| – Measuring sockets | | |
| • Ramp time "t <" | U | 20 mV to 5 V |
| • Ramp time "t >" | U | 20 mV to 5 V |
| • Actual value "x" | U | 0 to +10 V |
| • Command value "w" | U | 0 to +10 V |
| Type of connection | | 12 screw terminals |
| Type of mounting | | Top hat rail TH 35-7.5 according to EN 60715 |
| Protection class | | IP 20 according to EN 60529 |
| Dimensions (W x H x D) | | 40 x 79 x 85.5 mm |
| Admissible operating temperature range | ϑ | 0 to +50 °C |
| Storage temperature range | ϑ | –25 °C to +70 °C |
| Weight | m | 0.14 kg |

Notice:

For information on the **environment simulation testing** for the areas EMC (electro-magnetic compatibility), climate and mechanical load, see data sheet 30221-U.

Terminal assignment

| | | | | | |
|---------------------------------|-----------------|---|----|----------|---|
| Operating voltage | +U _B | 1 | 7 | Solenoid | Connection cable (recommendation): 2-wire cable, single shielded, cross-section 1.5 mm ² |
| | 0 V | 2 | 8 | | |
| Enable | U _F | 3 | 9 | Free | |
| Differential input | -IN | 4 | 10 | | |
| | +IN | 5 | 11 | 2 | Position transducer control |
| Position transducer return feed | 1 | 6 | 12 | ⊥ | |

Dimensions (dimensions in mm)

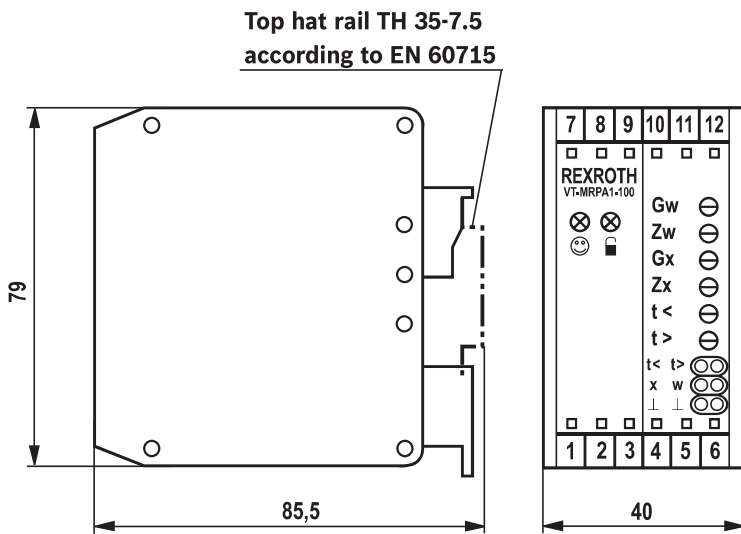

LED indicators:

- ☺ Ready for operation (green)
- ☑ Enable (yellow)

Potentiometer:

- Gw Amplitude attenuator for positive command values
- Gx Sensitivity adjustment of positional transducer (pre-set)
- Zw Zero point command value
- Zx Zero point actual value
- t < Ramp time for increasing command values
- t > Ramp time for decreasing command values

Measuring sockets:

- t < Ramp time "up"
- t > Ramp time "down"
- x Actual value
- w Command value
- ⊥ Measurement zero

Project planning/maintenance instructions/additional information

- ▶ The amplifier module may only be wired when de-energized.
- ▶ Do not lay lines close to power cables.
- ▶ Do not use free-wheeling diodes in the solenoid conductors.
- ▶ The distance to aerial lines, radios, and radar systems has to be 1 m at least.
- ▶ Always shield command value and position transducer lines; connect shielding to protective earthing (PE) on the module side.
In some cases (e.g. if PE is subject to strong interference) it can be necessary to connect the shield of the position transducer line directly to the LO of the amplifier module; other side open (risk of ground loops).
- ▶ Recommendation:
Also shield solenoid conductors!
For solenoid lines up to a length of 50 m, use cable type LiYCY 1.5 mm².
For longer lines, please consult us.
- ▶ Do not connect terminal "⊥" of the position transducer connector to "PE".
- ▶ For switching command values, relays with gold-plated contacts have to be used (low voltages, low currents).
- ▶ Only carry out measurements at the module using instruments with $R_i > 100 \text{ k}\Omega$
- ▶ With a strongly fluctuating operating voltage, it may in the individual case be necessary to use an external smoothing capacitor with a capacity of at least 2200 μF .
Recommendation: Capacitor module VT 11110 (see data sheet 30750); sufficient for up to 3 amplifier modules
- ▶ **Notice:**
When exchanging VT 11025, VT 11033 or VT 11034, please observe the different terminal assignment of the position transducer connector. Terminals "6" and "12" are swapped.

Setting recommendation

The system-specific circuitry must have been completed.

| Signal | Setting MRPA1 |
|---|---|
| Command value zero point | Apply enable signal |
| | Preset the external command value to zero |
| | Set the internal command value to zero using the "Zw" zero point potentiometer and carry out a check at measuring socket "w" |
| Actual value zero point | Enable signal "OFF" or pull solenoid plug (valve moves to mechanical end position) |
| | For all settings, observe polarity of measuring device → measuring sockets |
| Ramp times | Set ramp time according to formula or table (see functional description "Ramp generator") and check it at the "t >" and "t <" measuring sockets |
| Maximum value (amplitude attenuator "Gw") | Notice: Before comparing the maximum value, the zero point must have been set correctly. |
| | Preset command value = 100% |
| | Set maximum control output using the "Gw" potentiometer and carry out a check at measuring socket "w" |

Notes

Bosch Rexroth AG
Hydraulics
Zum Eisengießer 1
97816 Lohr am Main, Germany
Phone +49 (0) 93 52/18-0
documentation@boschrexroth.de
www.boschrexroth.de

© This document, as well as the data, specifications and other information set forth in it, are the exclusive property of Bosch Rexroth AG. It may not be reproduced or given to third parties without its consent.
The data specified above only serve to describe the product. No statements concerning a certain condition or suitability for a certain application can be derived from our information. The information given does not release the user from the obligation of own judgment and verification. It must be remembered that our products are subject to a natural process of wear and aging.